

**MITSUBISHI
DIESEL ENGINE**

6D24-TUM

for **MG560**

— 掲 載 内 容 —

本カタログは、エンジン編です。次の車体カタログと
合わせてご利用ください。

MG560 車体 Pub.No. 98160-48900

NOTE

This parts catalogue is a engine volume.
It is requested that this catalogue be used in
combination with the following parts catalogue:

MG560 Chassis Parts Catalogue

Pub.No.98160-48900

February 2005

まえがき

このパーツカタログは、1990年6月以降生産の「6D2型産業用エンジン」に使用されている補用部品を収録してあります。

エンジン型式等の詳細は、後述の「収録エンジン型式一覧表」をご参照下さい。

このパーツカタログを有効に活用いただくには、「イラスト・部品番号リストの見方」を十分にご理解いただくことが重要です。

(部品番号は予告なく変更することがありますので、予めご了承ください。)

(参考)

年号対照表

西暦	1990	1991	1992	1993	1994
元号	平成2	平成3	平成4	平成5	平成6

西暦	1995	1996	1997	1998	1999
元号	平成7	平成8	平成9	平成10	平成11

西暦	2000	2001	2002	2003	2004
元号	平成12	平成13	平成14	平成15	平成16

★★★★★★★★★★★★★★★★★★★★★★★★★★★★★★★★★★★★★★

三菱ふそう純正部品のご使用について

三菱のエンジンには「三菱ふそう純正部品」をご使用ください。

「三菱ふそう純正部品」は弊社の卓越した品質管理のもとで厳格な検査に合格した優秀な部品ですから、安心してご使用していただけるものです。

イミテーション部品は材質、製造方法などすべての点で純正部品と比較にならないので、ご使用にならないでください。「三菱ふそう純正部品」は弊社販売会社に豊富に取りそろえてありますので、「三菱ふそう純正部品」とご指定のうえ、最寄りの販売会社でお買い求めください。

★★★★★★★★★★★★★★★★★★★★★★★★★★★★★★★★★★★★★★

特殊工具は記載されておりません。整備解説書または、特殊工具一覧表を参照して下さい。
(供給は補用部品ルートでいたします。)

Pub. No. 98160-43930

FOREWORD

This Parts Catalog contains information on service parts for the 6D2 industrial engines manufactured for customers in general since June 1990.

For the detail of the engine models, refer to the List of Applicable Engine Models herein contained.

In order to use this catalog effectively, it is important to gain a good understanding of "HOW TO USE ILLUSTRATION AND PART NO. LIST".
(The part numbers may be changed without prior notice.)

★★★★★★★★★★★★★★★★★★★★★★★★★★★★★★★★★★★★★★

mitsubishi fuso genuine parts

Use "mitsubishi fuso genuine parts" exclusively for servicing your Mitsubishi engine.

"mitsubishi fuso genuine parts" are superior and reliable because they have been produced under the excellent quality-control system, and have passed the standard after strict inspections.

Imitation parts are not recommended from the viewpoint of their material and manufacturing method which are entirely incomparable with those of genuine parts.

A large assortment of "mitsubishi fuso genuine parts" is always available at any of our authorized dealers, so do your purchasing at your nearest dealer by specifying "mitsubishi fuso genuine parts".

★★★★★★★★★★★★★★★★★★★★★★★★★★★★★★★★★★★★★★

This Parts Catalog does not cover the special tools, for which please refer to the Workshop Manual or the List of Special Tools. (The special tools are available through the service part supply route.)

適用エンジン番号のしらべ方

HOW TO LOCATE APPLICABLE ENGINE NO.

シリンダブロックの下図の位置に打刻してあります。

The engine number is stamped on the cylinder block at the location shown in the following illustration.

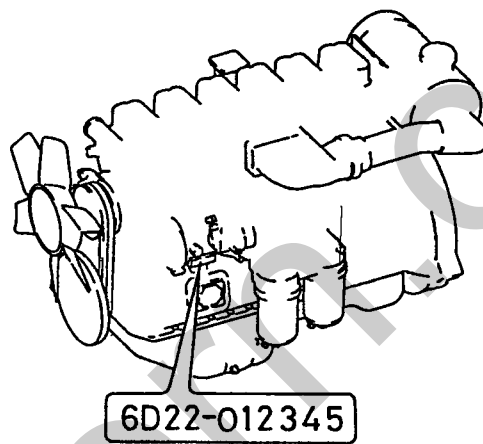

収録エンジン型式一覧表

LIST OF APPLICABLE ENGINE MODELS

エンジン型式名称 Engine model name	エンジン型式記号 Engine model code		適用機種 Applicable machine, vehicle, etc.	適用エンジン番号 Applicable engine No.
	型式	類別		
6D22-T	6D221	CTJS12000	MG530	6D22-179303(90/6)~
	6D221	CTJS12131	MG530 雪寒 60Amp オルタネータ For cold regions Alternator	
6D24-TUM	6D240	CTJS04000	MG560 欧州向 For Europe	6D24-287558(99/1)~
	6D240	CTJS04US1	MG560 50Amp オルタネータ Alternator	6D24-344468(03/12)~

イラスト・部品番号リストの見方

イラスト・部品番号リストは次の通り記載しています。

① ②

11-210 ピストン, コネクティング ロッド & クランクシャフト

③ 6D2

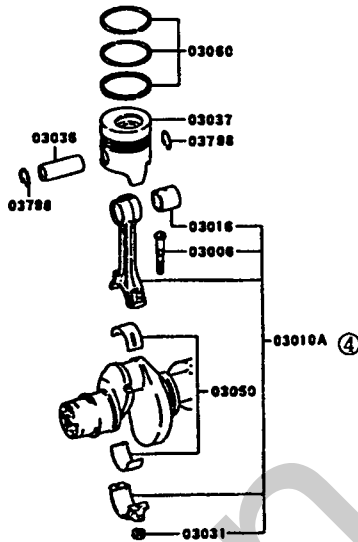

⑭ 230020

① ②

11-210 ピストン, コネクティング ロッド & クランクシャフト

④ ⑤ ⑥ ⑦ ⑧ ⑨ 02 6D311 CTJS01131 ⑩ ⑪ ⑫ ⑬

見出番号 REF.-NO.	部品番号 PART NO.	R S C E N P O G	部品名称および記事・仕様記号 PART NAME & DESCRIPTION	型式・個数 MODEL & QTY				適用号機 APPLICABLE SERIAL NO.	管 径 M M φ	長 度 M M	重 量 G
				0	1	2					
03006	ME012232		BOLT, CONNROD 12X85	12	12			1100-1			
03010A	ME012265		CONNECTING ROD ASSY	6	6			1100-1			
03016	ME012234		BUSHING, CONNROD	6	6			1100-1			
03021	ME023769		CONE, CRANKSHAFT PULLEY	1	1			1100-1			
03022	ME068101		DAMPER, CRANKSHAFT TORSIONAL	1	1			1100-1			
03031	ME023570		NUT, CONNROD FLANGE, 12	12	12			1100-1			
03036	ME012009		PIN, PISTON 34X84	6	6			1100-1			
03037	ME012858		PISTON STD	6	6			1100-1			
03037	ME012859		PISTON Q/SIZE 0.25	6	6			1100-1			
03037	ME012860		PISTON Q/SIZE 0.50	6	6			1100-1			

① グループ番号

メイン・サブグループのNo.を示します。メイン・サブグループ及びグループ名称を熟知されると部品番号検索がより容易になります。

② サブグループ名称

サブグループの名称を示し、それぞれのグループに収録されている代表部品および装置の名称などを示します。

③ イラスト特徴

それぞれのイラストタイトルとしてふさわしい、エンジン型式、年式などの特徴項目を示します。

④ 見出番号

イラストと部品番号リストを結びつける役目をします。

左側、右側の区分は次のように表示します。

〔例〕 左側 =

12047L

 マニホールド, エキゾースト, フロントLH

右側 =

12047R

 マニホールド, エキゾースト, フロントRH

⑤ 部品番号

当該エンジンに使用している部品番号を示します。

⑥ 代替部品

部品の変更には、互換性のある変更とない変更とがあります。このうち、新部品が旧部品の代わりに使用できるとき、新部品を旧部品の代替部品といい次のように表示します。

1) 代替欄におけるマークの意味

マーク	意味
R	新・旧部品のどちらでも使用できる場合
3	新部品は旧部品の代わりに使用でき、旧部品は旧エンジンにのみ使用できる場合
#	新部品を旧部品の代わりに使用するとき、条件付きの代替部品があることを示します。

2) 代替部品番号の見方

見出番号 REF-NO.	部品番号 PART NO.	代替 R/P	変 更 記 号 S E N G	部品名称および記事・仕様記号 PART NAME & DESCRIPTION	型式・個数 MODEL & QTY				適用号機 APPLICABLE SERIAL NO. FROM@-----@UPTO	管 区 M / R	新 規 V R D
					0 1	0 2					
04903A	MD008784 (MD132260)	3		CAP ASSY, ENG OIL FILLER	1	1			9106 - 1		

() 内の部品番号は代替新部品番号を示します。

⑦ 変更順番号, 変更記号 (今回は省略してあります。)

1) 変更順番号

部品の変更経歴順に1, 2……と付番しています。

2) 変更記号

部品の変更等の内容を記号で表示しています。

⑧ 部品名称

部品名称は補足名称も含めて示します。

⑨ 型式・適用

該当部品が使用される型式を示します。このパーツカタログに収録されているエンジン型式の詳細は“収録エンジン型式一覧表”をご覧ください。

⑩ 個数

エンジン 1 台分の使用個数を示します。

⑪ 適用号機

当該部品を使用しているエンジンの生産開始・終了時期を示します。

〔例〕 9010・2 - 9107・1

1990年10月中旬から

↓

1991年7月初旬まで生産

(1 : 初旬 2 : 中旬 3 : 下旬)

⑫ 管理区分 (今回は省略してあります)

この欄に“A”の表示がある部品は、高需要部品の意味を表します。
各代理店殿におかれましては、常時在庫品の目安にしてください。

⑬ 新規部品記号

前回発行後に変更のあった部品、又は新規に発生した部品に対し“V”を表示してあります。

⑭ イラスト管理No.

弊社におけるイラスト管理のためのNo.です。

ご 注 意

パーツカタログ上のイラストは部品の形状、位置を部品注文に支障のない範囲で示してあります。

HOW TO USE ILLUSTRATION AND PART NO. LIST

The illustrations and part No. list are prepared as follows:

- ① ②

11-210 PISTON, CONNECTING ROD & CRANKSHAFT

③ 6D2

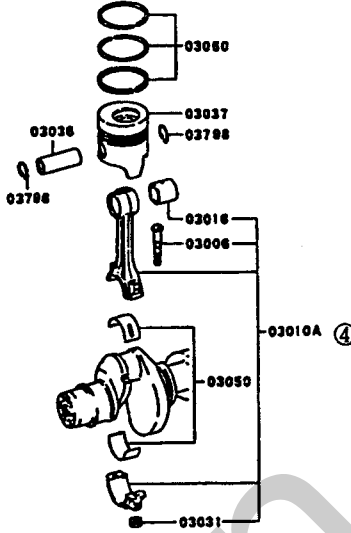

⑭ 2G0020

- ① ②

11-210 PISTON, CONNECTING ROD & CRANKSHAFT

④ ⑤ ⑥ ⑦ ⑧ ⑨ 02 6D311 CTJS01131 ⑩ ⑪ ⑫ ⑬
01 6D311 CTJS01000

④ 見出番号 REF.-NO.	⑤ 部品番号 PART NO.	⑥ ⑦ 代 理 商 R S C / E N P G G	⑧ 部品名称 および 記事・仕様記号 PART NAME & DESCRIPTION	⑩ 型式・個数 MODEL & QTY				⑪ 適用号機 APPLICABLE SERIAL NO.		⑫ 管 径 M M φ	⑬ 管 長 M M φ
				0	0	1	2	FROM	TO		
03006	ME012232		BOLT, CONNROD 12X85	12	12			9100-1			
03010A	ME012265		CONNECTING ROD ASSY	6	6			9100-1			
03016	ME012234		BUSHING, CONNROD	6	6			9100-1			
03021	ME023769		CONE, CRANKSHAFT PULLEY	1	1			9100-1			
03022	ME088T01		DAMPER, CRANKSHAFT TORSIONAL	1	1			9100-1			
03031	ME023570		NUT, CONNROD FLANGE, 12	12	12			9100-1			
03036	ME012009		PIN, PISTON 34X84	6	6			9100-1			
03037	ME012858		PISTON STD	6	6			9100-1			
03037	ME012859		PISTON O/SIZE 0.25	6	6			9100-1			
03037	ME012860		PISTON O/SIZE 0.50	6	6			9100-1			

① Group No.

The Main-Sub Group No. is indicated. An intimate knowledge of the Main-Sub Group and Group Titles will facilitate the retrieval of the part numbers.

② Sub Group Title

Indicates the title of the Sub Group. The titles show the names of the representative parts, equipment or the like contained in the respective groups.

③ Illustration feature

Indicates the engine model, model year, destination code and other appropriate feature items for the respective illustrations.

④ Reference number

Serves to combine the illustration with the part number list.

The LH and RH parts are indicated as follows.

[Example] LH part= 12047L MANIFOLD,EXHAUST,FRONT,LH

RH part= 12047R MANIFOLD,EXHAUST,FRONT,RH

⑤ Part No.

Indicates the part number of the part used for the applicable engine model.

⑥ Replacement part(R/P)

Changes made in a part involve the change which permits interchange of parts and that not permitting interchange of parts. When a new part can be used in place of the old part, the new part is called replacement part of the old part and indicated as follows:

1) Meaning of each mark used in replacement(R/P)column

Mark	Meaning
R	Either new part or old part may be used.
3	New part may be used in place of old part but old part may be used on old engine only.
#	New part may be used in place of old part under a certain condition.

2) Replacement part number

見出番号 REF-NO.	部品番号 PART NO.	代替 R / P	変 順 記 号 S E N G	部品名称および記事・仕様記号 PART NAME & DESCRIPTION	型式・個数 MODEL & QTY				適用号機 APPLICABLE SERIAL NO.		管 区 M / R	新 規 V R D
					0 1	0 2			FROM@-	@UPTO		
04903A	MD008784 (MD132260)	3		CAP ASSY, ENG OIL FILLER	1	1			9106 ·			
									1			

The part No. shown in () is a replacement part number.

⑦ Sequence of change numbers & Change codes (Omitted)

1) Sequence of changed numbers

The parts are changed for improved quality or performance. Their changes are indicated in sequence by numerals (1.2.3...).

2) Change codes

These codes indicate the reason or purpose of changes of the parts.

⑧ Part name

The part name is indicated together with the complementary name.

⑨ Model type /Description

The applicable models of respective parts are indicated in this column.

For the detail of the engine models put in this Parts Catalog, refer to the "LIST OF APPLICABLE ENGINE MODELS".

⑩ Quantity

Indicates the number of parts used per engine.

⑪ Applicable serial numbers

Indicates the date of beginning the production of the engine incorporating the applicable part and that of ending its production.

[Example] 9010·2 - 9107·1

Built from the middle of October 1990 up to early in July 1991

(1:early, 2:middle 3:late)

⑫ Management rank (Omitted)

Parts ranked as "A" are high-demand parts. This ranking is to be referred to by dealers, and is devised to facilitate and rationalize their distribution, stocking and inventory of the parts.

⑬ Parts changed or added after the last parts catalogue that has been published are identified by "V".

⑭ Illustration control No.

This number is used for illustration control by Mitsubishi.

N O T E

The illustrations in this Parts Catalog show the part shape and location only to be adequate for ordering of the part.

エンジン番号一覧表

LIST OF ENGINE NUMBERS

YEAR	ENG MODEL	1月	2月	3月	4月	5月	6月	7月	8月	9月	10月	11月	12月
		Jan	Feb	Mar	Apr	May	Jun	Jul	Aug	Sep	Oct	Nov	Dec
1990	6D221	174080	175155	176107	177089	178084	179151	180399	181513	182610	183773	184863	186521

YEAR	ENG MODEL	1月	2月	3月	4月	5月	6月	7月	8月	9月	10月	11月	12月
		Jan	Feb	Mar	Apr	May	Jun	Jul	Aug	Sep	Oct	Nov	Dec
1991	6D221	187714	188635	189875	191147	192333	193752	194942	196037	196839	198108	199278	200290

YEAR	ENG MODEL	1月	2月	3月	4月	5月	6月	7月	8月	9月	10月	11月	12月
		Jan	Feb	Mar	Apr	May	Jun	Jul	Aug	Sep	Oct	Nov	Dec
1992	6D221	201427	202487	203697	204766	205438	206507	207634	208593	209600	210843	211905	212959

YEAR	ENG MODEL	1月	2月	3月	4月	5月	6月	7月	8月	9月	10月	11月	12月
		Jan	Feb	Mar	Apr	May	Jun	Jul	Aug	Sep	Oct	Nov	Dec
1993	6D221	213808	214713	215757	216847	217981	219028	219956	221093	221920	222799	223879	224843

YEAR	ENG MODEL	1月	2月	3月	4月	5月	6月	7月	8月	9月	10月	11月	12月
		Jan	Feb	Mar	Apr	May	Jun	Jul	Aug	Sep	Oct	Nov	Dec
1994	6D221	225681	226389	227252	228055	228545	229076	229882	230648	231272	232246	233273	234414

YEAR	ENG MODEL	1月	2月	3月	4月	5月	6月	7月	8月	9月	10月	11月	12月
		Jan	Feb	Mar	Apr	May	Jun	Jul	Aug	Sep	Oct	Nov	Dec
1995	6D221	235828	236974	238262	240166	241389	242564	244122	245458	246637	247778	248791	249535

YEAR	ENG MODEL	1月	2月	3月	4月	5月	6月	7月	8月	9月	10月	11月	12月
		Jan	Feb	Mar	Apr	May	Jun	Jul	Aug	Sep	Oct	Nov	Dec
1995	6D240	-	-	-	239839	240521	-	243955	244925	246170	248157	249069	249434

YEAR	ENG MODEL	1月	2月	3月	4月	5月	6月	7月	8月	9月	10月	11月	12月
		Jan	Feb	Mar	Apr	May	Jun	Jul	Aug	Sep	Oct	Nov	Dec
1996	6D221	250365	251174	251952	252946	253899	254984	256202	257551	258600	259810	260970	262217

YEAR	ENG MODEL	1月	2月	3月	4月	5月	6月	7月	8月	9月	10月	11月	12月
		Jan	Feb	Mar	Apr	May	Jun	Jul	Aug	Sep	Oct	Nov	Dec
1996	6D240	250313	251170	252070	253060	253884	255082	256174	257492	258593	259768	261012	262234

YEAR	ENG	1月	2月	3月	4月	5月	6月	7月	8月	9月	10月	11月	12月
	MODEL	Jan	Feb	Mar	Apr	May	Jun	Jul	Aug	Sep	Oct	Nov	Dec
1997	6D221	263263	264327	265353	266504	267475	468576	569772	271363	272742	274218	275482	276646

YEAR	ENG	1月	2月	3月	4月	5月	6月	7月	8月	9月	10月	11月	12月
	MODEL	Jan	Feb	Mar	Apr	May	Jun	Jul	Aug	Sep	Oct	Nov	Dec
1997	6D240	263268	264377	265386	266532	267542	268630	269793	271432	272755	274282	275487	276705

YEAR	ENG	1月	2月	3月	4月	5月	6月	7月	8月	9月	10月	11月	12月
	MODEL	Jan	Feb	Mar	Apr	May	Jun	Jul	Aug	Sep	Oct	Nov	Dec
1998	6D221	277707	278486	279500	280326	280961	281696	282489	283369	284090	285057	285717	286462

YEAR	ENG	1月	2月	3月	4月	5月	6月	7月	8月	9月	10月	11月	12月
	MODEL	Jan	Feb	Mar	Apr	May	Jun	Jul	Aug	Sep	Oct	Nov	Dec
1998	6D240	277703	278524	279576	280312	281010	281717	282501	283341	284037	284954	285720	286515

YEAR	ENG	1月	2月	3月	4月	5月	6月	7月	8月	9月	10月	11月	12月
	MODEL	Jan	Feb	Mar	Apr	May	Jun	Jul	Aug	Sep	Oct	Nov	Dec
1999	6D221	287295	287948	288795	289560	290397	291156	292166	292950	293679	294554	295429	296113

YEAR	ENG	1月	2月	3月	4月	5月	6月	7月	8月	9月	10月	11月	12月
	MODEL	Jan	Feb	Mar	Apr	May	Jun	Jul	Aug	Sep	Oct	Nov	Dec
1999	6D240	287228	287953	288739	289564	290417	291121	292109	292988	293669	294442	295327	296139

YEAR	ENG	1月	2月	3月	4月	5月	6月	7月	8月	9月	10月	11月	12月
	MODEL	Jan	Feb	Mar	Apr	May	Jun	Jul	Aug	Sep	Oct	Nov	Dec
2000	6D221	297059	297841	298892	300174	301052	302047	303052	303978	304770	306071	307061	308241

YEAR	ENG	1月	2月	3月	4月	5月	6月	7月	8月	9月	10月	11月	12月
	MODEL	Jan	Feb	Mar	Apr	May	Jun	Jul	Aug	Sep	Oct	Nov	Dec
2000	6D240	297056	297902	298942	300161	301067	302056	303114	304139	304785	305883	307091	308155

YEAR	ENG	1月	2月	3月	4月	5月	6月	7月	8月	9月	10月	11月	12月
	MODEL	Jan	Feb	Mar	Apr	May	Jun	Jul	Aug	Sep	Oct	Nov	Dec
2001	6D221	309175	309965	310796	311820	312737	313372	314442	315045	316073	-	317196	-

YEAR	ENG	1月	2月	3月	4月	5月	6月	7月	8月	9月	10月	11月	12月
	MODEL	Jan	Feb	Mar	Apr	May	Jun	Jul	Aug	Sep	Oct	Nov	Dec
2001	6D240	309123	309976	310744	311644	312456	313235	313898	314870	315592	316405	317144	317993

YEAR	ENG	1月	2月	3月	4月	5月	6月	7月	8月	9月	10月	11月	12月
	MODEL	Jan	Feb	Mar	Apr	May	Jun	Jul	Aug	Sep	Oct	Nov	Dec
2002	6D221	319053	319737	320769	321437	-	322552	-	-	324604	-	-	328716

YEAR	ENG	1月	2月	3月	4月	5月	6月	7月	8月	9月	10月	11月	12月
	MODEL	Jan	Feb	Mar	Apr	May	Jun	Jul	Aug	Sep	Oct	Nov	Dec
2002	6D240	318897	319627	320476	321230	321872	322469	323361	324469	325604	326650	327558	328614

YEAR	ENG	1月	2月	3月	4月	5月	6月	7月	8月	9月	10月	11月	12月
	MODEL	Jan	Feb	Mar	Apr	May	Jun	Jul	Aug	Sep	Oct	Nov	Dec
2003	6D221	-	-	332188	333515	334948	335816	336714	-	340009	-	344172	-

YEAR	ENG	1月	2月	3月	4月	5月	6月	7月	8月	9月	10月	11月	12月
	MODEL	Jan	Feb	Mar	Apr	May	Jun	Jul	Aug	Sep	Oct	Nov	Dec
2003	6D240	329628	330810	331964	332916	334204	335198	336525	338415	339655	341183	342622	344255

YEAR	ENG	1月	2月	3月	4月	5月	6月	7月	8月	9月	10月	11月	12月
	MODEL	Jan	Feb	Mar	Apr	May	Jun	Jul	Aug	Sep	Oct	Nov	Dec
2004	6D221	-											

YEAR	ENG	1月	2月	3月	4月	5月	6月	7月	8月	9月	10月	11月	12月
	MODEL	Jan	Feb	Mar	Apr	May	Jun	Jul	Aug	Sep	Oct	Nov	Dec
2004	6D240	345935											

記号・略語一覧表

ABBREVIATIONS AND SYMBOLS

(M)	: Metallic(メタリック)	ナックル	: Steering Knuckle (ステアリング ナックル)
(P)	: Pearl(パール)	ハイドロ	: Hydraulic(ハイドロリック)
&	: And(アンド)	バランサ	: Counterbalancer(カウンタ バランサ)
*MHI	: 三菱重工業株式会社(販社直購品)	パーク	: Parking(パークینگ)
*ND	: 株式会社デンソー(販社直購品)	パワステ	: Power Steering(パワー ステアリング)
アキム	: Accumulator(アキムレータ)	ブッシュ	: Bushing(ブッシュ)
アクセル	: Accel(Accelerator) Accelerator(アクセルレータ)	ブレーカ	: Contact Breaker(コンタクト ブレーカ)
アクチュエート	: Actuating(アクチュエーティング)	プロポバルブ	: Proportioning Valve (プロポーションング バルブ)
アジャスト	: Adjusting(アジャスティング)	ペラシャフト	: Propeller Shaft(プロペラ シャフト)
アタッチ	: Attachment(アタッチメント)	ボタン	: Push Button(プッシュ ボタン)
アンプ	: Amplifier(アンプリファイヤ)	マイク	: Microphone(マイクホン)
インタメシャフト	: Intermediate Shaft (インタメジエイト シャフト)	マウント	: Mounting(マウンティング)
インパネ	: Instrument Panel (インストルメント パネル)	マルチ	: Multiple(マルチプル)
ウインド	: Windshield(ウインドシールド)	モール	: Moulding(モールディング)
ウエザ	: W/Strip(Weatherstrip) Weatherstrip(ウエザストリップ)	リーンホース	: Reinforcement (リーンホースメント)
エアアウト	: Air Outlet(エア アウトレット)	リクライ	: Reclining(リクライニング)
エアイン	: Air Inlet(エア インレット)	リサーキュレート	: Recirculation(リサーキュレーション)
エアコン	: Air Conditioner(エア コンディショナ)	リモコン	: Remote Control(リモート コントロール)
エアサス	: Air Suspension(エア サスペンション)	ルブリケート	: Lubricating(ルブリケーティング)
イクイブ	: Equip(Equipment) Equipment(イクイブメント)	レギュレート	: Regulating(レギュレーティング)
オート	: Auto(Automatic) Automatic(オートマチック)	レデュース	: Reducing(レデュースング)
オペレート	: Operating(オペレーティング)	ロック	: Locking(ロックング)
カウルベント	: Cowl Ventilator(カウル ベンチレータ)	ロッド	: Push Rod(プッシュ ロッド)
コネクト	: Connecting(コネクティング)	A	: Ampere(アンペア)
コンパート	: Compartment(コンパートメント)	A/C	: Air Conditioner(エア コンディショナ)
コンビ	: Combination(コンビネーション)	A/GLNR	: Air Cleaner(エア クリーナ)
コンプレッサ	: Air Compressor(エア コンプレッサ)	ASR	: Anti-Spin Regulator (アンチスピン レギュレーター)
コンペンセート	: Compensating(コンペンセーティング)	A/SUSP	: Air Suspension(エア サスペンション)
コンロッド	: Connecting Rod(コネクティング ロッド)	A/T	: Auto Transaxle(オートトランスアクスル) Auto Transmission (オートトランスミッション)
サス	: Susp(Suspension) Suspension(サスペンション)	ABS	: Anti-Lock Brake Control System (アンチロック ブレーキ コントロール システム)
ショック	: Shock Absorber(ショックアブソーバ)	ABSジュシ	: アクリロニトル・ブタジエン・スチレン・ジュシ
シンクロ	: Synch(Synchronizer) Synchronizer(シンクロナイザ)	AC	: Alternating Current(交流)
スプラッシュ	: Splash Shield(スプラッシュ シールド)	ACCEL	: Accelerator(アクセルレータ)
スライド	: Sliding(スライディング)	ACV	: Air Cut Valve(エア カット バルブ)
ターボ	: T/C(Turbocharger) Turbocharger(ターボチャージャー)	AGPM	: Auto Glare Proof Mirror (自動防眩ミラー)
チャージ	: Charging(チャージング)	A/H	: Air Over Hydraulic Brake (エアオーバ ハイドロリックブレーキ)
デカル	: Decalomania(デカルコマニヤ)	AL	: Aluminum(アルミニウム)
デコンプ	: Decompression(デコンプレッション)	AL/WHL	: Alminum Wheel(アルミニウムホイール)
デフ	: Differential(デファレンシャル)	ALR	: Auto Lock Retractor (オートロックリトラクタ)
トルコン	: Torque Converter(トルクコンバータ)	ALTNTR	: Alternator(オルタネータ)

AM	: Amplitude Modulation (アンプリチュート モデュレーション)	CHK	: Check(チェック)
ANTI-CORR	: Anti-Corrosion(アンチ コロージョン)	CHR	: Charger(チャージャ)
ANTI-POLL	: Anti-Pollution(アンチ ホリューション)	CHR	: Chrome(クロム)
AR	: As Required(所要量)	CKT	: Circuit(回路)
ARG	: Argent(アーゼント)	CL	: Clutch(クラッチ)
ASC	: Auto Speed Control (オート スピード コントロール)	CL-	: Cool(クール)
ASSY	: Assembly(アセンブリ)	CLO	: Cloth(クロス)
AUTO	: Automatic(オートマチック)	CLO/ST	: Cloth Seat(クロス シート)
AUX	: Auxiliary(オグシリアリ)	CLR	: Cooler(クーラ)
A001	: (株)ADオーバースーズ	CLRLS	: Inter Cooler Less (インタ クーラレス)
A082	: 曙ブレーキ工業株式会社	CM/T	: Column Shift M/T(コラムシフト M/T)
A126	: 安全自動車(株)	CNG	: Compressed Natural Gas (圧縮天然ガス)
A139	: 青木科学研究所	COL	: Colored(カラー)
A216	: 旭硝子株式会社	COMPR	: Compressor(コンプレッサ)
B-	: Bright(ブライ)	CONNROD	: Connecting Rod(コネクティング ロッド)
BATT	: Battery(バッテリー)	CONST	: Construction(コンストラクション)
BGE	: Beige(ベージュ)	CONT	: Control(コントロール)
BJ	: Birfield Joint (バーフィールド ジョイント)	CR-	: Creamy(クリーミ)
BLA	: Black(ブラック)	CRU/CONT	: Cruise Control(クルーズ コントロール)
BLU	: Blue(ブルー)	CTR	: Center(センタ)
BMPR	: Bumper(バンパ)	CZ	: Cold Zone(寒冷地)
BOSCH	: ボッシュ株式会社	C010	: クラリオン(株)
BPV	: Blend Proportioning Valve (ブレンド プロポーションング バルブ)	C012	: セントラル産業(株)
BRG	: Bearing(ベアリング)	D	: Diameter(直径)
BRK	: Brake(ブレーキ)	D-	: Dark(ダーク)
BRKT	: Bracket(ブラケット)	D/ミラー	: Door Mirror(ドア ミラー)
BRN	: Brown(ブラウン)	D/リモコン	: Direct Remote Control (ダイレクト リモート コントロール)
BRT	: Bright(ブライ)	D/MR	: Door Mirror(ドア ミラー)
BRZ	: Bronze(ブロンズ)	D/PR	: Dust Proof(ダスト プルーフ)
BSTR	: Booster(ブースタ)	D/PROOF	: Dust Proof(ダスト プルーフ)
B020	: (株)ハンザイ	D/T	: ディーゼルトターボ
B070	: (株)ボッシュブレーキシステム	DBL	: Double(ダブル)
B078	: (株)ボッシュオートモーティブシステム	DC	: Direct Current(直流)
C-	: Clear(クリア)	DD	: Direct Drive(ダイレクトドライブ)
C-LP	: Courtesy Lamp(コर्टイシ ランプ)	DECAL	: Decalcomania(デカルコマニヤ)
C/Lルーフ	: クリスタルライトルーフ	DEFOG	: Defogger(デフォグガ)
C/UP	: Capacity Up(容量アップ)	DIFF	: Differential(デファレンシャル)
C/ZONE	: Cold Zone(寒冷地)	DIR	: Direct(ダイレクト)
CA/CONV	: Catalytic Converter(触媒)	DIR/CONT	: Direct Control(ダイレクト コントロール)
CA/T	: Column Shift A/T(コラムシフト A/T)	DOHC	: Double Overhead Camshaft (ダブル オーバヘッド カムシャフト)
CARB	: Carburetor(キャブレタ)	DOJ	: Double Offset Joint (ダブル オフセット ジョイント)
CAS/PLAY	: Cassette Player(カセット プレーヤ)	DOM	: Domestic(トメスティック)
CC	: Choice(選択)	DQ	: ダイヤクイーン
CD	: Compact Disc(コンパクト ディスク)	DR	: Door(ドア)
CHARG	: Charger(チャージャ)		

DRL	: Day Time Running Light (デー タイム ランニング ライト)	EZGO	: Easy Go(坂道発進補助装置& パーキングサポートシステム/イージーゴー)
DSV	: Deceleration Solenoid Valve (デセレーション ソレノイド バルブ)	F/A	: Full Air Brake(フルエアブレーキ)
D001	: ダイヤケミカル(株)	Fクランプ	: フットクランプ
D253	: チェセル機器株式会社	F-N-R	: Forward, Neutral & Reverse (フォワード, ニュートラル & リバース)
EC	: Electric Control (エレクトリック コントロール)	F/ミラー	: Fender Mirror(フェンダ ミラー)
ECI	: Electronic Control Injection (エレクトロニック コントロール インジェクション)	F/DISC	: Front Disc(フロント ディスク)
ECM	: Electronic Control Engine Mounting (エレクトロニック コントロール エンジン マウンティング)	F/MR	: Fender Mirror(フェンダ ミラー)
ECS	: Electronic Control Suspension (エレクトロニック コントロール サスペンション)	F/PWR	: Full Power(フルパワー)
ECU	: Electronic Control Unit (エレクトロニック コントロール ユニット)	F/TANK	: Fuel Tank(燃料タンク)
ED	: Economy Drive(エコミドライブ)	F/TRAILER	: Full Trailer(フルトレーラ)
EGR	: Exhaust Gas Recirculation (排ガス再循環装置)	F/W	: Flywheel(フライホイール)
ELCAT	: Electronic Control Auto Transmission (エレクトロニック コントロール オートトランスミッション)	FA/T	: Floor Shift A/T(フロア シフト A/T)
ELEC	: Electric(エレクトリック)	FL/CPG	: Fluid Coupling(フルイド カップリング)
ELEC/CONT	: Electric Control (エレクトリック コントロール)	FLAME/	: Flammability Resistance
ELR	: Emergency Lock Retractor (エマージェンシ ロック リトラクタ)	RESIST	(難燃仕様)
EMERG	: Emergency(緊急)	FLUOR	: Fluorescent(蛍光灯)
ENG	: Engine(エンジン)	FM	: Frequency Modulation (フリークエンシ モデュレーション)
EPS	: Electronic Control Power Steering (エレクトロニック コントロール パワー ステアリング)	FM/T	: Floor Shift M/T(フロア シフト M/T)
EQUIP	: Equipment(イクイプメント)	FR	: Front(フロント)
ESS	: Engine Speed Sensor (エンジン スピード センサ)	FRP	: ガラス繊維強化プラスチック
ESV	: Enrichment Solenoid Valve (エンリッチメント ソレノイド バルブ)	FWD	: Forward(フォワード)
ETACS	: Electronic Time & Alarm Control System (エレクトロニック タイム & アラーム コントロール システム)	G-	: Grayish(グレイッシュ)
ETR	: Electronic Tuner(エレクトロニック チューナ)	G/RATIO	: Gear Ratio(ギヤ比)
EVA	: エチレン酢ビ樹脂	G/ZONE	: General Zone(一般地域)
EXC	: Except(除く)	GER	: Germany(ジャーマニー)
EXH	: Exhaust(エキゾースト)	GLA	: Glass(ガラス)
EXP	: Export(エクスポート)	GLD	: Gold(ゴールド)
EXT	: Exterior(エクステリア, 外装コート)	GOV	: Governor(ガバナ)
		GRG	: Grayge(グレイージュ)
		GRL	: Grille(グリル)
		GRN	: Green(グリーン)
		GRY	: Gray(グレイ)
		GT	: Ground Touring(グラント ツーリング)
		GZ	: General Zone(一般地域)
		H-L	: High & Low(ハイ & ロー)
		H/ミラー	: Hood Mirror(フード ミラー)
		H/BACK	: Hatch Back(ハッチ バック)
		H/DUTY	: Heavy Duty(ヘビー デューティ)
		H/GRADE	: High Grade(ハイ グレード)
		H/GROUND	: High Ground(ハイ グラウンド)
		H/LP	: Headlamp(ヘッドランプ)
		H/MR	: Hood Mirror(フード ミラー)
		H/REST	: Headrest(ヘッドレスト)
		H/ZONE	: Hot Zone(酷暑地)
		HA	: High Altitude(高地)

HAC	: High Altitude Compensator (高地補正装置)	L/B	: Lock Brake(ロックブレーキ)
HCO	: Height Control(ハイトコントロール)	LCD	: Liquid Crystal Display(液晶)
HI	: High(ハイ)	LEA	: Leather(レザー)
HL/WSHR	: Headlamp Washer(ヘッドランプ ワッシャー)	LEA/ST	: Leather Seat(レザーシート)
HLG	: Halogen(ハロゲン)	LED	: Light Emitting Diode (ライトエミティングダイオード)
HMSLツキ	: ハイマウントストップランプ付	LH	: Left Hand(左側)
HTL	: Heater Less(ヒーターレス)	LHD	: Left Hand Drive(レフトハンドドライブ)
HTR	: Heater(ヒーター)	LOG	: Loading(積載量)
HZ	: Hot Zone(酷暑地)	LP	: Lamp(ランプ)
H022	: ハマニ化成(株)	LPG	: Liquid Propane Gas(液化ガス)
H086	: (株)初田製作所	LRG	: Large(ラージ)
H158	: 日野屋貿易(株)	LSD	: Limited Slip Differential (リミテッドスリップデフアレンシャル)
I/CLR	: Inter Cooler(インタクーラ)	LSP	: Load Sensing Proportioning (ロードセンシングプロポーションング)
I/PANEL	: Instrument Panel(インストルメントパネル)	LSPV	: Load Sensing Proportioning Valve (ロードセンシングプロポーションングバルブ)
I/PNL	: Instrument Panel(インストルメントパネル)	LSV	: Load Sensing Valve (ロードセンシングバルブ)
IC	: Integrated Circuit (インテグレートドサーキット)	LW	: Long Wave(長波)
INCR/TANK	: Increased Tank(増量タンク)	LWR	: Lower(ロー)
INDEP	: Independent(独立)	M-	: Medium(ミディアム)
INJ	: Injection(噴射)	MBECS	: Motorvehicle Brake Energy Conservation System (制動エネルギー回生システム/エムベックス)
INOMAT	: Intelligent & Innovative Mechanical Automatic Transmission (機械式自動トランスミッション/イノマト)	M/CYL	: Master Cylinder(マスタシリンダ)
INR	: Inner(インナ)	MDAS	: Mitsubishi Driver's Attention Monitoring System (運転注意力モニター/エムダス)
INT	: Interior(インテリア, 内装コート)	MILS	: Mitsubishi Intelligent Load Monitoring System(積載モニター/ミルス)
ISS	: Idling Stop & Start System (アイリングストップ & スタートシステム)	M/T	: Manual Transaxle(マニュアルトランスアクスル) Manual Transmission (マニュアルトランスミッション)
IVO	: Ivory(アイボリー)	M/TOP	: Metal Top(メタルトップ)
I010	: 出光興産(株)	MAG	: Magnet(マグネット)
JMSV	: Jet Mixture Solenoid Valve (ジェットミックスチャソレノイドバルブ)	MALAY	: Malaysia(マレーシア)
J015	: ジェコ(株)	MAX	: Maximum(マキシマム)
KPH	: Kilometer Per Hour (キロメートル/時間)	MCV	: Mixture Control Valve (ミックスチャコントロールバルブ)
KW	: Kilo Watt(キロワット)	MECH	: Mechanical(メカニカル)
K068	: コスヘル化工(株)(兼松江商)	MHI	: 三菱重工工業株式会社
K480	: 株式会社 小糸製作所	MICS	: Mitsubishi Intelligent Cockpit System (三菱インテリジエントコックピットシステム)
K481	: (株)小糸製作所		
K558	: (株)コシダテック		
K698	: クシロブレーキ株式会社		
K838	: 協和商工(株)		
L	: Length(長さ)		
L-	: Light(ライト)		
L-R	: Low & Reverse(ロー & リバース)		
LAV	: Lavender(ラベンダー)		
LB	: Pound(ポンド)		

MID	: Middle(ミドル)	N361	: 日本ヘルメックス(株)
MIN	: Minimum(ミニマム)	N386	: 日本金属精工(株)
MIQCS	: Mitsubishi Innovative Quiescent Combustion System (クワイエッセント燃焼/ミックス)	N416	: 日本ロックタイト(株)
MIR	: Mirror(ミラー)	N437	: 日本パワーステアリング株式会社
MLDG	: Moulding(モールドイング)	N438	: 日本パーライジング(株)
MMAT	: Mitsubishi Mechanical Automatic Transmission (三菱メカニカル オートマチックトランスミッション)	N464	: 日本濾過器株式会社
MMCS	: Mitsubishi Multi Communication System (三菱 マルチ コミュニケーション システム)	N530	: 日本特殊陶業株式会社
MPH	: Mile Per Hour(マイル/時間)	N634	: (株)日豊商事
MPI	: Multi Point Injection (マルチ ポイント インジェクション)	N687	: 日清紡プレーキ販売株式会社
MPX	: Multiplex(マルチプレックス)	N812	: (株)リタケ
MRN	: Maroon(マロン)	O-	: Off(オフ)
MTR	: Meter(メータ)	O/D	: Overdrive(オーバードライブ)
MW	: Middle Wave(中波)	O/S	: Outside(アウトサイド)
M018	: (株)万喜商会	OD	: Outside Diameter(外径) Overdrive(オーバードライブ)
M039	: 丸愛産業(株)	OHC	: Overhead Camshaft (オーバヘッド カムシャフト)
M150	: 松下電気産業(株)	OHV	: Overhead Valve(オーバヘッドバルブ)
M236	: ミドリ安全(株)	OLI	: Olive(オリーブ)
M264	: (株)ミコ	OP	: Option Code(オプションコード)
M304	: 水戸工業(株)	OPN	: Open(オープン) Opener(オープナ)
M321	: 三菱電機株式会社	ORG	: Orange(オレンジ)
M360	: 三菱製鋼株式会社	OS	: Oversize(オーバサイズ)
M400	: 三菱商事(株)	OTR	: Outer(アウト)
M507	: 三菱マテリアル建材株式会社	OWC	: One Way Clutch(ワンウェイクラッチ)
M754	: (株)モリタ	O252	: (株)大沢ローヤル
M814	: 睦商事(株)	P/NO	: Part Number(部品番号)
N-	: Natural(ナチュラル)	P/S	: Power Steering(パワーステアリング)
NA	: Not Applicable(非適用)	P/SEAT	: Passenger Seat(パセンジャシート) Power Seat(パワーシート)
NAS	: North American Spec (ノースアメリカン スペック)	P/W	: Power Window(パワーウインドウ)
ND	: 株式会社デンソー	PAF	: Pulse Air Feeder(パルスエアフィーダ)
NIKK	: 日本インジェクタ株式会社	PAR	: Parch(パーチ)
NO.	: Number(番号)	PC	: Piece(ピース)
NS	: Not Service(非供給)	PCV	: Purge Control Valve (パージコントロールバルブ)
N243	: ニューレイトン(株)	PHV	: Pressure Hold Valve (プレッシャホールドバルブ)
N259	: (株)ナブコ	PLR	: Pillar(ピラー)
N268	: 日本パース(株)	PNC	: Part Name Code(品名コード)
N274	: 日本グリース(株)	PNK	: Pink(ピンク)
N282	: 日本カーリット(株)	PNL	: Panel(パネル)
N305	: 株式会社デンソー	PP/AR	: ポリプロピレン/エラストマー
N318	: 日本ドナルドソン株式会社	PP/PEコンボウ	: ポリプロピレン/ポリエチレンコンボウ
N324	: 日本ドライケミカル(株)	PRESS	: Pressure(プレッシャ)
		PRL	: Pearl(パール)
		PROT	: Protect(プロテクト)

PROT	Protector(プロテクタ)	SCE	: Source(ソース)
PT	: Point(ポイント)	SD	: Sand(サント)
PTO	: Power Take Off(パワー テーク オフ)	SE-	: Semi(セミ)
PWR	: Power(パワー)	SERV	: Service(サービス)
P016	: パイオニア(株)	SIK	: Service In Kit(キット供給)
P022	: (株)パシフィックモーターケミカルズ	SIL	: Silver(シルバ)
Q/GLOW	: Quick Glow(クイック グロー)	SIR	: Service In Roll(長尺供給)
Q/WDO	: Quarter Window(クォータ ウインドウ)	SOHC	: Single Overhead Camshaft (シングル オーバヘッド カムシャフト)
QTR	: Quarter(クォータ)	SP	: Spoke(スポーク)
QTY	: Quantity(個数)	SPEC	: Specification(仕様)
R/CONT	: Remote Control(リモート コントロール)	SPI	: Single Point Injection (シングル ポイント インジェクション)
R/DRUM	: Rear Drum(リヤ ドラム)	SPKR	: Speaker(スピーカ)
RAD	: Radiator(ラジエータ)	SPR	: Spring(スプリング)
RDC	: Reducing(レジュースング)	SPT	: Sputtering(スパッタリング)
RDO	: Radio(ラジオ)	SSPS	: Speed Sensing Power Steering (車速感応パワーステアリング装置)
RE	: Red(レッド)	ST	: Seat(シート)
RED	: Reduction(リダクション)	STAB	: Stabilizer(スタビライザ)
REFRD	: Refrigerated(冷凍)	STD	: Standard(スタンダード)
REINF	: Reinforcement(リーンフォースメント)	STRG	: Steering(ステアリング)
REL	: Release(リリース)	SUS	: Suspension(サスペンション)
REP	: Replacement Code(代替性コード)	SUSP	: Suspension(サスペンション)
REV	: Reverse(リバース)	SW	: Switch(スイッチ) Short Wave(短波)
RF	: Roof(ルーフ)/ファイナル	SYNCH	: Synchronizer(シンクロナイザ)
RH	: Right Hand(右側)	SYS	: System(システム)
RHD	: Right Hand Drive(ライト ハンド ドライブ)	S066	: (株)サミット
RJ	: Rzeppa Universal Joint (ゼツパ ユニバーサル ジョイント)	S068	: (株)サン自動車工業
RPM	: Revolutions Per Minute (回転数/分)	S081	: サンエス化学工業(株)
RPS	: Revolutions Per Second (回転数/秒)	S145	: 三興油脂(株)
RR	: Rear(リヤ)	S216	: (株)サンダイヤ
RSB	: Raspberry(ラズベリー)	S247	: 三輪精機株式会社
RTD	: Retarder(リターダ)	S351	: シールエント(株)
RWD	: Rearward(リヤワート)	S504	: サンヨー商事(株)
R058	: (株)リンレイ	S602	: 三菱自動車テクノサービス(株)
R155	: (株)菱和	S613	: (株)シノフ
R190	: 菱自用品販売(株)	S616	: 新正工業(株)
S-	: Soft(ソフト)	S639	: シロヤ被服工業(株)
S/ABS	: Shock Absorber(ショック アブソーバ)	S641	: 静岡化成(株)
S/BELT	: Seat Belt(シート ベルト)	S664	: スタンレー電気株式会社
S/C	: Super Charger(スーパー チャージャ)	S811	: 昭和飛行機工業(株)
S/METER	: Speedometer(スピードメータ)	S815	: 正和工業(株)
S/R	: Sunroof(サンルーフ)	S822	: 昭和シェル石油(株)
S/STRCT	: Side Structure(サイド ストラクチャ)	T	: Thickness(厚さ)
S/TRAILER	: Semi Trailer(セミトレーラ)	T/A	: Transaxle(トランスアクスル)
S/WHL	: Steering Wheel(ステアリング ホイール)	T/C	: Turbocharger(ターボチャージャ)
S/WDO	: Side Window(サイド ウインドウ)		

T/F	: Transfer(トランスファ)	VNL	: Vinyl(ビニール)
T/GATE	: Tail Gate(テールゲート)	VNL/ST	: Vinyl Seat(ビニールシート)
T/M	: Transmission(トランスミッション)	VOIS	: Visual & Oral Information System (多重表示&音声警報システム/ボイス)
TA	: TAN(タン)	VOL	: Volume(ボリューム)
TACHO	: Tachometer(タコメータ)	V/S	: Vacuum Servo Brake (バキュームサーボブレーキ)
TCL	: Traction Control System (駆動力制御機構)	VSS	: Vehicle Speed Sensor (ビークルスピードセンサ)
TEL	: Telephone(電話)	VTR	: Video Tape Recorder (ビデオテープレコーダ)
TEMP	: Temperature(温度)	W	: Watt(ワット)
TI	: Titanium(チタン)	WB	: Wheel Base(ホイールベース)
TJ	: Tripod Universal Joint (トリポッドユニバーサルジョイント)	W-	: Warm(ワーム)
TOR-CON	: Torque Converter(トルクコンバータ)	W/	: With(〜ツキ)
TORO	: 東京濾過器株式会社	W/CLR	: With Inter Cooler(インタクーラツキ)
TPR	: 変性ポリプロピレン	W/INJ	: Wax Injection(ワックスインジェクション)
TRQ	: Turquoise(ターコイズ)	W/O	: Without(〜ナシ)
TURBO	: Turbocharger(ターボチャージャー)	W/P	: Wheel Parking Brake (ホイールパーキングブレーキ)
TV	: Television(テレビジョン)	W/SHLD	: Windshield(ウインドシールド)
T016	: 大平潤販(株)	W/STRIP	: Weatherstrip(ウエザーストリップ)
T159	: 効ラ産業(株)	WD	: Wood(ウッド)
T356	: (株)スリーポイント	WDO	: Window(ウインドウ)
T378	: 千代田工販(株)	WHT	: White(ホワイト)
T392	: (株)トーケン	WO	: Without(〜ナシ)
T540	: ティーピーケイ販売(株)	WO/WPR	: Without Wiper(ワイパナシ)
T595	: 東京濾過器株式会社	WSHR	: Washer(ワッシャ)
T698	: トピー実業(株)	WT/WPR	: With Wiper(ワイパツキ)
T716	: トーシテック(株)	W016	: 和興産業株式会社
T725	: 栃木富士産業(株)	YEL	: Yellow(イエロ)
T752	: (株)東洋アイテック	Y094	: (株)山三商事
T826	: 東洋製鎖工業(株)	Y205	: 矢崎総業(株)
T955	: (株)中外	Y223	: 横浜ゴム(株)
T984	: 中央交易(株)	Y320	: ユシロ化学工業(株)
UCC	: Under Catalytic Converter (アンダキャタリテックコンバータ)	Y325	: 輸送機工業株式会社
UPR	: Upper(アッパ)	Y699	: 三菱自動車工業(株)国内部品部
US	: Undersize(アンダサイズ)	ZZ	: More Than 100(100個以上)
U023	: (株)U.S.C	Z025	: 自動車動力興業(株)
U027	: (株)ユニワールト産業	1ST	: First(ファースト)
V	: Volt(ボルト)	2ND	: Second(セカンド)
VAL	: Valve(バルブ)	3PT	: 3 Point(スリーポイント)
VEH	: Vehicle(車両)	3RD	: Third(サード)
VELNAS	: Vehicle Electronic Navigation System (ビークルエレクトロニックナビゲーションシステム)	4TH	: Fourth(フォース)
VENT	: Ventilator(ベンチレータ)	4WD	: Four Wheel Drive(4輪駆動)
VIN	: Vehicle Identification Number (ビークルアイデンティフィケーションナンバー)	4WS	: Four Wheel Steering(4輪操舵)
VIO	: Violet(バイオレット)	50Hz/60Hz	: 50ヘルツ/60ヘルツ

目 次 CONTENTS

グループ番号 GROUP NO.	グループ名称 GROUP NAME	ページ PAGE
エンジン ENGINE		
11-020	ショートエンジンアセンブリ SHORT ENGINE ASSY	2
11-030	サービスシリンダヘッドアセンブリ SERVICE CYLINDER HEAD ASSY	4
11-040	サービスシリンダブロックアセンブリ SERVICE CYLINDER BLOCK ASSY	6
11-050	ライナ & ピストンキット LINER & PISTON KIT	8
11-060	サービスクランクシャフトアセンブリ SERVICE CRANKSHAFT ASSY	10
11-090	エンジンオーバーホールガスケットキット ENGINE OVERHAUL GASKET KIT	12
11-110	ロッカカバー & ブリザ ROCKER COVER & BREATHER	14
11-120	シリンダヘッド CYLINDER HEAD	16
11-130	シリンダブロック CYLINDER BLOCK	18
11-140	オイルパン、フィラ & ゲージ OIL PAN, FILLER & GAUGE	24
11-150	フライホイール & ハウジング FLYWHEEL & HOUSING	28
11-210	ピストン、コネクティングロッド & クランクシャフト PISTON, CONNROD & CRANKSHAFT	34
11-230	カムシャフト & バルブ CAMSHAFT & VALVE	38
11-240	タイミングギヤ TIMING GEAR	42
11-340	エアコンプレッサ AIR COMPRESSOR	46
11-410	アタッチングパーツ ATTACHING PARTS	54
潤滑 LUBRICATION		
12-110	オイルポンプ & ストレーナ OIL PUMP & STRAINER	60
12-120	オイルフィルタ OIL FILTER	64
12-130	オイルクーラ OIL COOLER	68
12-140	オイルライン OIL LINE	74
燃料 FUEL		
13-030	燃料フィルタ & ホース FUEL FILTER & HOSE	78
13-110	燃料インジェクションポンプ 一般 FUEL INJECTION PUMP GENERAL	82
13-120	インジェクションポンプ INJECTION PUMP	84
13-160	ガバナ GOVERNOR	94

目 次 CONTENTS

グループ番号 GROUP NO.	グループ名称 GROUP NAME	ページ PAGE	
13-270	オートマチックタイマ AUTOMATIC TIMER	106	
13-290	フューエルフィードポンプ FUEL FEED PUMP	110	
13-320	カップリング COUPLING	112	
13-410	インジェクションパイプ & ノズル INJECTION PIPE & NOZZLE	114	
13-420	フューエルリターンホース FUEL RETURN HOSE	126	
クーリング COOLING			
14-110	ウォーターポンプ & ファン WATER PUMP & FAN	128	
14-120	ウォーターパイプ & サモスタット WATER PIPE & THERMOSTAT	132	
インテーク & エキゾースト INTAKE & EXHAUST			
15-210	インレットマニホールド INLET MANIFOLD	136	
15-310	エキゾーストマニホールド EXHAUST MANIFOLD	138	
15-410	ターボチャージャー TURBOCHARGER	140	
15-510	エキゾーストパイプ EXHAUST PIPE	144	
エンジン電気 ENGINE ELECTRICAL			
16-010	スタータ STARTER	146	
16-110	オルタネータ & レギュレータ ALTERNATOR & REGULATOR	154	
ステアリング STEERING			
37-110	パワーステアリングオイルポンプ POWER STEERING OIL PUMP	166	
キャブ & ボデー CAB & BODY			
42-550	プレート & ラベル PLATE & LABEL	168	
シャシ電気 CHASSIS ELECTRICAL			
54-730	シャシハネスイクイップメント CHASSIS HARNESS EQUIPMENT	170	
部品番号順索引 PARTS NUMBER INDEX			A1

目 次
CONTENTS

グループ番号 GROUP NO.	グループ名称 GROUP NAME	ページ PAGE
部品名称順索引 PARTS NAME INDEX	B1

Silverhorn.CO.UK

Silverhorn.CO.UK

イラスト・部品番号リスト

Silverhorn.CO.UK

11 -020 ショートエンジンアセンブリ
SHORT ENGINE ASSY

-2-

01010A

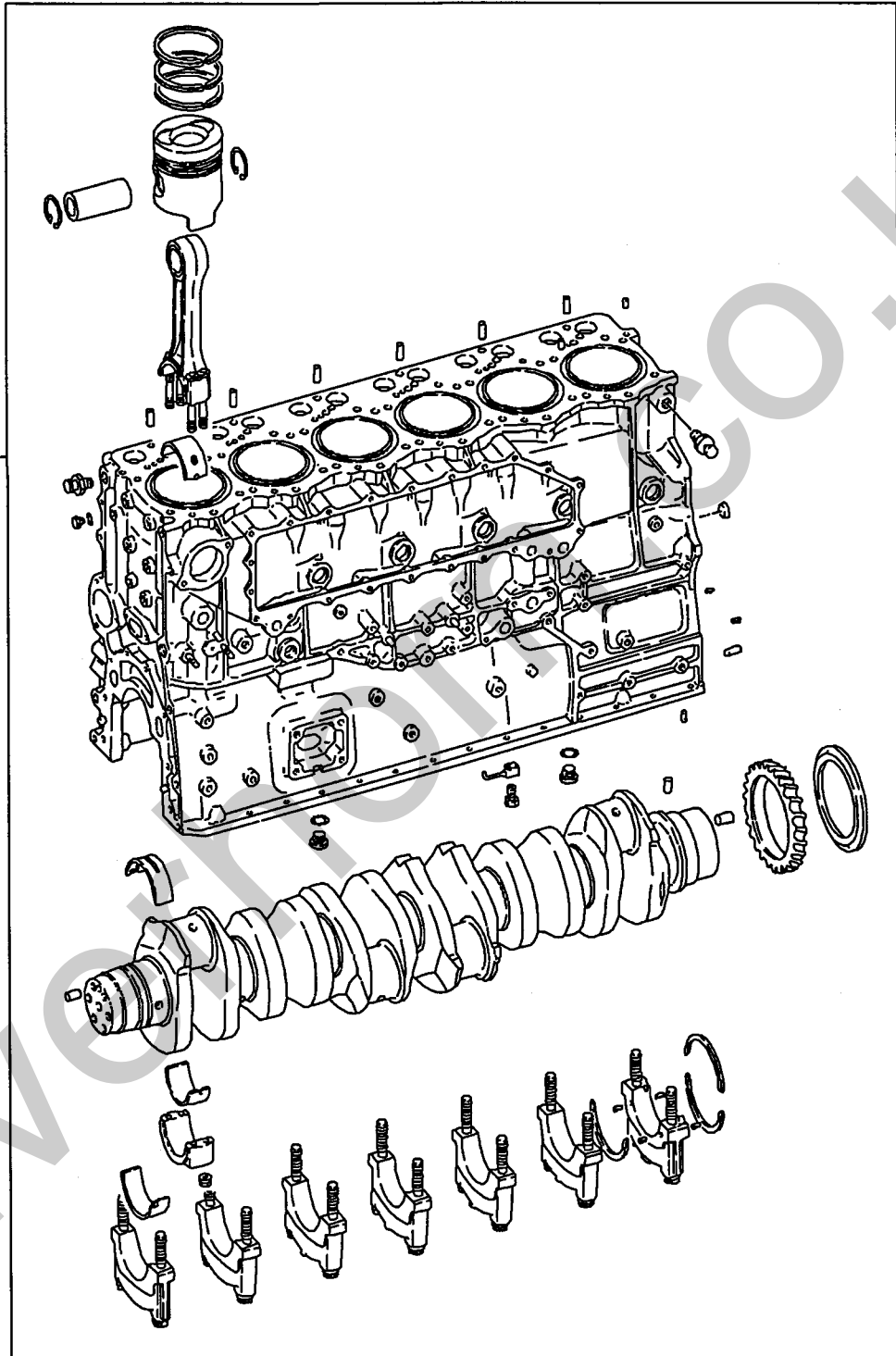

200T01

11 -020 SHORT ENGINE ASSY

ショートエンジンアセンブリ

04 6D240 CTJS04US1
 03 6D240 CTJS04000
 02 6D221 CTJS12131 COLD
 01 6D221 CTJS12000 STD

-3-

見出番号 REF.-NO.	部品番号 PART NO.	代 替 R / P 記 号 S C E N P O G	部品名称および記事・仕様記号 PART NAME & DESCRIPTION	型式・個数 MODEL & QTY						適用号機 APPLICABLE SERIAL NO.		管 区 M / R	新 規 V R D	
				0	1	2	3	4		FROM@	@UPTO			
01010A	ME157733 (ME993132)	3	ENGINE ASSY,SHORT	1	1						9006-1	9912-2		
	ME993132 (ME993817)	3	ENGINE ASSY,SHORT	1	1						9912-3	0303-3		
	ME993817		ENGINE ASSY,SHORT	1	1						0304-1			V
	ME995622 (ME993135)	3	ENGINE ASSY,SHORT			1	1				9901-1	9912-2		
	ME993135 (ME993459)	3	ENGINE ASSY,SHORT			1	1				9912-3	0110-3		
	ME993459 (ME993820)	3	ENGINE ASSY,SHORT			1	1				0111-1	0303-3		
	ME993820		ENGINE ASSY,SHORT			1	1				0304-1			V

11 -030 サービスシリンダ ヘッド アセンブリ
SERVICE CYLINDER HEAD ASSY

-4-

01200A

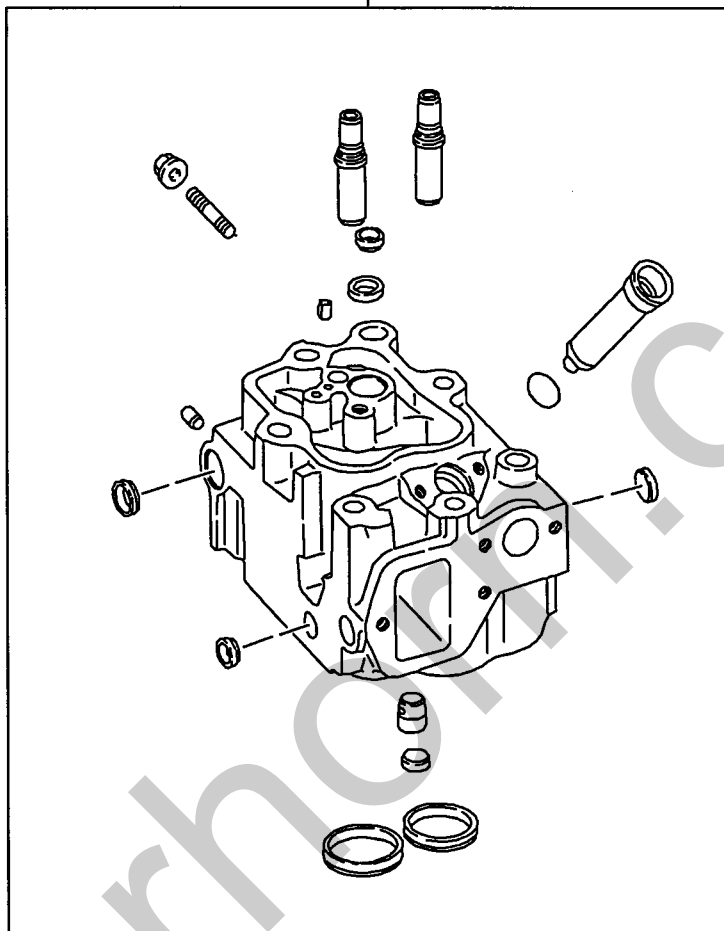

200T01

サビレスシリンダブロックアセンブリ
11 -040 SERVICE CYLINDER BLOCK ASSY

-6-

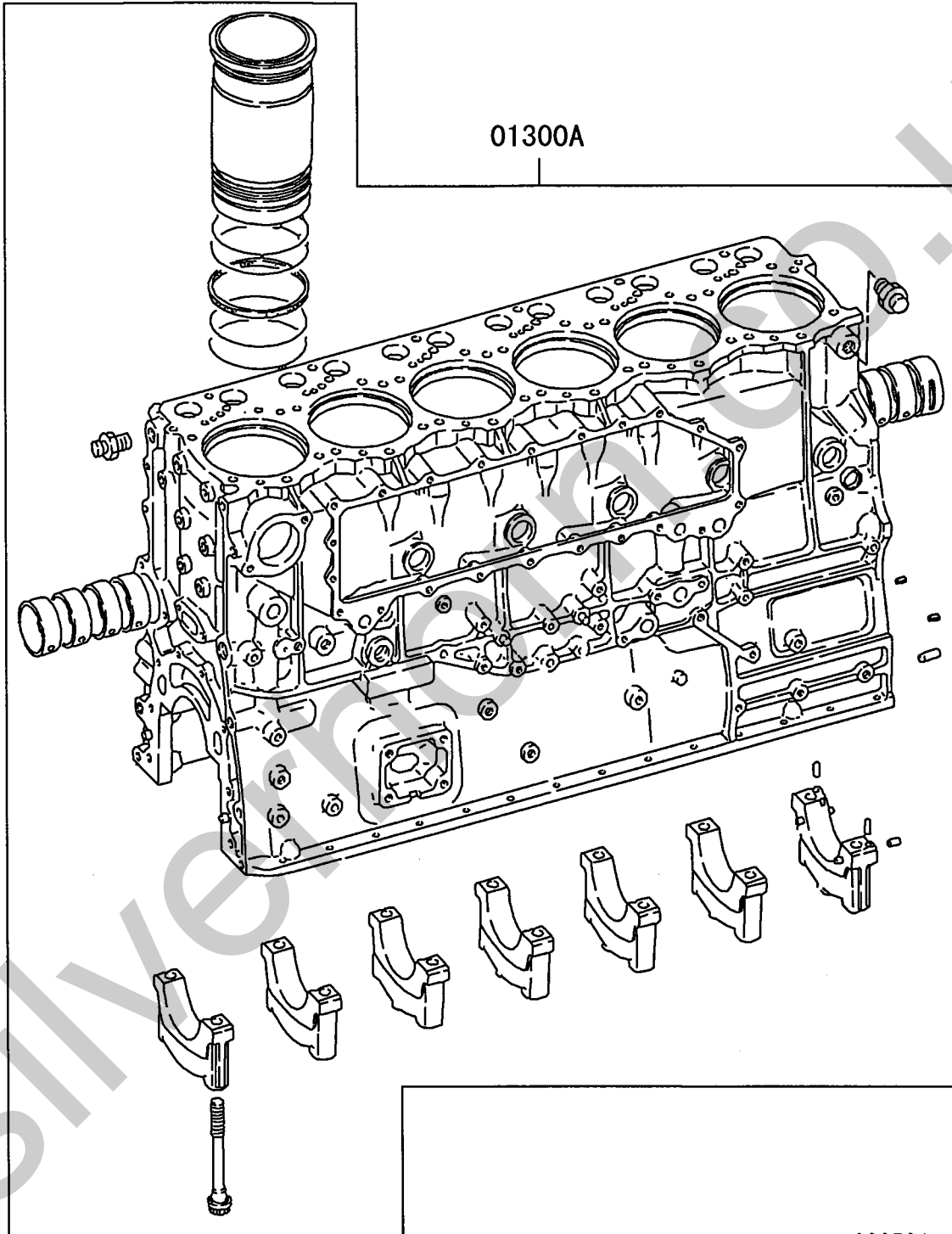

サービスシリンダ ブロックアセンブリ
11 -040 SERVICE CYLINDER BLOCK ASSY

04 6D240 CTJS04US1
03 6D240 CTJS04000
02 6D221 CTJS12131 COLD
01 6D221 CTJS12000 STD

-7-

見出番号 REF.-NO.	部品番号 PART NO.	代 替 R / P 変 更 順 号 S C E N E P O G	部品名称および記事・仕様記号 PART NAME & DESCRIPTION	型式・個数 MODEL & QTY					適用号機 APPLICABLE SERIAL NO.		管 区 M / R 新 規 V / R D
				0	1	2	3	4	FROM@	@UPTO	
01300A	ME997037	3	BLOCK ASSY,CYLINDER	1	1				9006・1	9502・3	
	ME996492 (ME995768)		BLOCK ASSY,CYLINDER	1	1				9503・1	9908・3	
	ME995768	#	BLOCK ASSY,CYLINDER	1	1				9909・1	9912・2	
	ME993085		BLOCK ASSY,CYLINDER T03050	1	1				9912・3	0303・3	
	ME993783	#	BLOCK ASSY,CYLINDER	1	1				0304・1		
	ME996149		BLOCK ASSY,CYLINDER T02023			1	1		9901・1	9908・3	
	ME995775	#	BLOCK ASSY,CYLINDER			1	1		9909・1	9912・2	
	ME993092		BLOCK ASSY,CYLINDER T02023			1	1		9912・3	0303・3	
	ME993779	#	BLOCK ASSY,CYLINDER T03049			1	1		0304・1		

11 -050 ライフ & ピストンキット
LINER & PISTON KIT

-8-

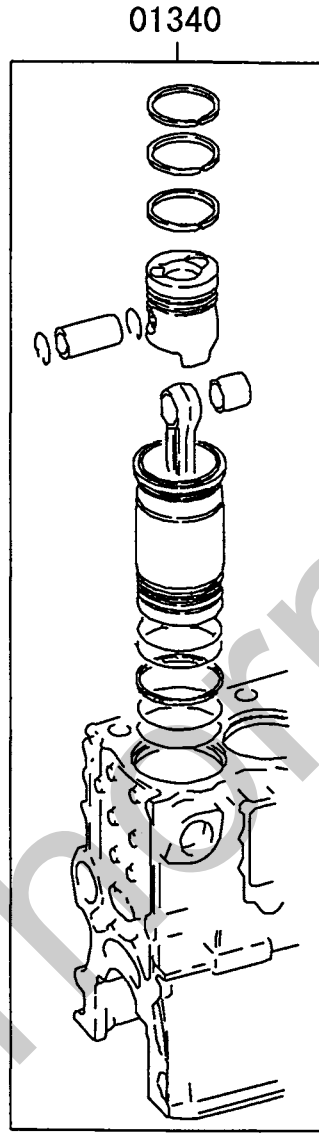

200T01

11 -060 サービス クランクシャフト アセンブリ
SERVICE CRANKSHAFT ASSY

-10-

03000A

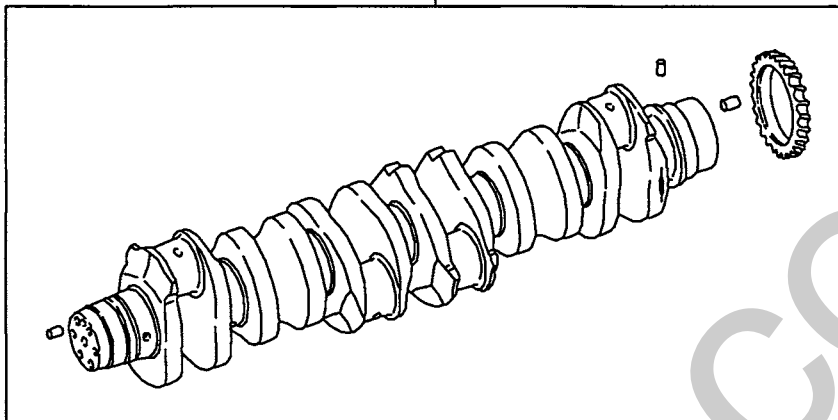

200T01

サービス クランクシャフト アセンブリ
11 -060 SERVICE CRANKSHAFT ASSY

04 6D240 CTJS04US1
03 6D240 CTJS04000
02 6D221 CTJS12131 COLD
01 6D221 CTJS12000 STD

-11-

見出番号 REF.-NO.	部品番号 PART NO.	代 替 順 号 R / P	実 記 号 S C E N P Q G	部品名称および記事・仕様記号 PART NAME & DESCRIPTION	型式・個数 MODEL & QTY						適用号機 APPLICABLE SERIAL NO.		新 規 区 M / R D	
					0	1	2	3	4			FROM@		@UPTO
03000A	ME999368	#		CRANKSHAFT ASSY T95039A	1	1						9006-1	9411-2	
	ME996339			CRANKSHAFT ASSY	1	1						9411-3	9912-2	
	ME993082			CRANKSHAFT ASSY	1	1						9912-3		
	ME996148			CRANKSHAFT ASSY			1	1				9901-1	9912-2	
	(ME993576)													
	ME993083 (ME993816) ME993816			3	CRANKSHAFT ASSY			1	1			9912-3	0205-3	
				CRANKSHAFT ASSY			1	1		0206-1		V		

01070

エンジンオーバーホールガasketキットの部品番号は標準エンジン用です。標準と異なる装置が装着されている場合は、構成部品に過不足が生じますので予めご了承ください。

The part number of engine overhaul gasket kit is that of the kit used for the standard engine. Please note that if the engine is provided with equipment other than the standard one, there is a kit component shortage or overage.

ロッカカバ & フリーザ
11 -110 ROCKER COVER & BREATHER

-14-

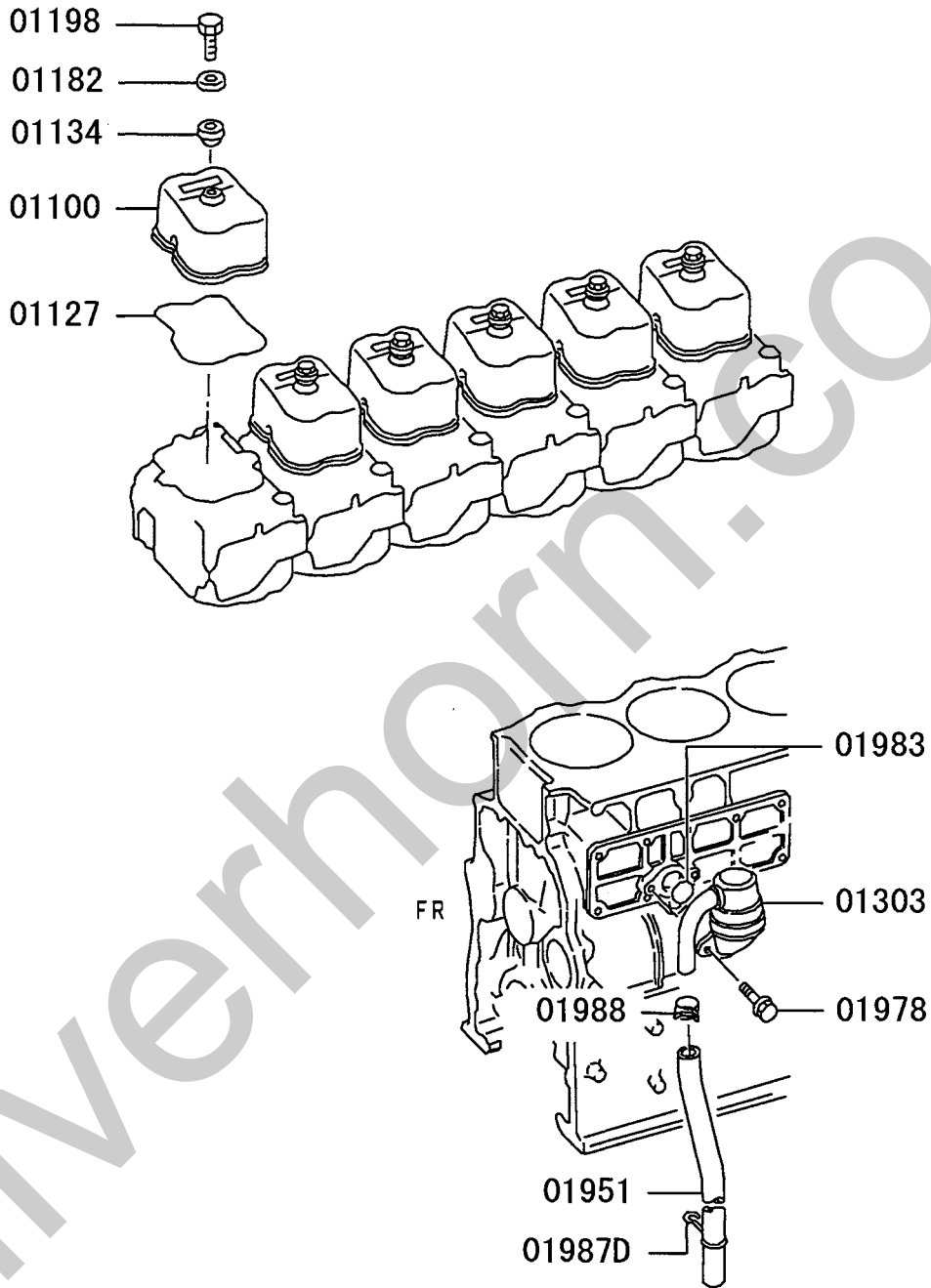

217T01

ロカカバ & ブリザ
11 -110 ROCKER COVER & BREATHER

04 6D240 CTJS04US1
03 6D240 CTJS04000
02 6D221 CTJS12131 COLD
01 6D221 CTJS12000 STD

-15-

見出番号 REF.-NO.	部品番号 PART NO.	代 替 R / P	変 更 順 号 S C E N E Q G	部品名称および記事・仕様記号 PART NAME & DESCRIPTION	型式・個数 MODEL & QTY					適用号機 APPLICABLE SERIAL NO. FROM@-@UPTO	管 区 M / R	新 規 V R D	
					0	1	2	3	4				
01100	ME051694			COVER,ROCKER	6	6	6	6			9006-1		
01127	ME051373			O-RING,ROCKER COVER	6	6	6	6			9006-1		
01134	MD000523			SEAL,ROCKER COVER BOLT RUBBER	6	6	6	6			9006-1		
01182	ME051705			WASHER,ROCKER COVER 8.5	6	6	6	6			9006-1		
01198	MH001103			BOLT,ROCKER COVER 8X28	6	6	6	6			9006-1		
01303	ME054385			BREATHER,ENG	1	1	1	1			9006-1		
01951	ME011910			HOSE,ENG BREATHER VINYL,24.5X550	1	1					9006-1	0006-2	
	ME058989			HOSE,ENG BREATHER VINYL,24.5X1000	1	1					0006-3		
	ME011910			HOSE,ENG BREATHER VINYL,24.5X550				1	1		9901-1	0001-3	
	ME058894			HOSE,ENG BREATHER VINYL,24.5X750				1	1		0002-1	0006-2	
	ME058989			HOSE,ENG BREATHER VINYL,24.5X1000				1	1		0006-3		
01978	MH000706			BOLT,ENG BREATHER FLANGE,10X16	2	2	2	2			9006-1		
01983	F315604500			O-RING,ENG BREATHER 45	1	1	1	1			9006-1		
01987D	3004211900			CLIP,ENG BREATHER	1	1	1	1			9006-1		
01988	MS660170			CLAMP,ENG BREATHER D=26	1	1					9006-1	0006-2	
	F430003201			CLAMP,ENG BREATHER D=30	1	1					0006-3		
	MS660170			CLAMP,ENG BREATHER D=26				1	1		9901-1	0001-3	
	F430003201			CLAMP,ENG BREATHER D=30				1	1		0002-1		

11 -120 シリンダヘッド CYLINDER HEAD

-16-

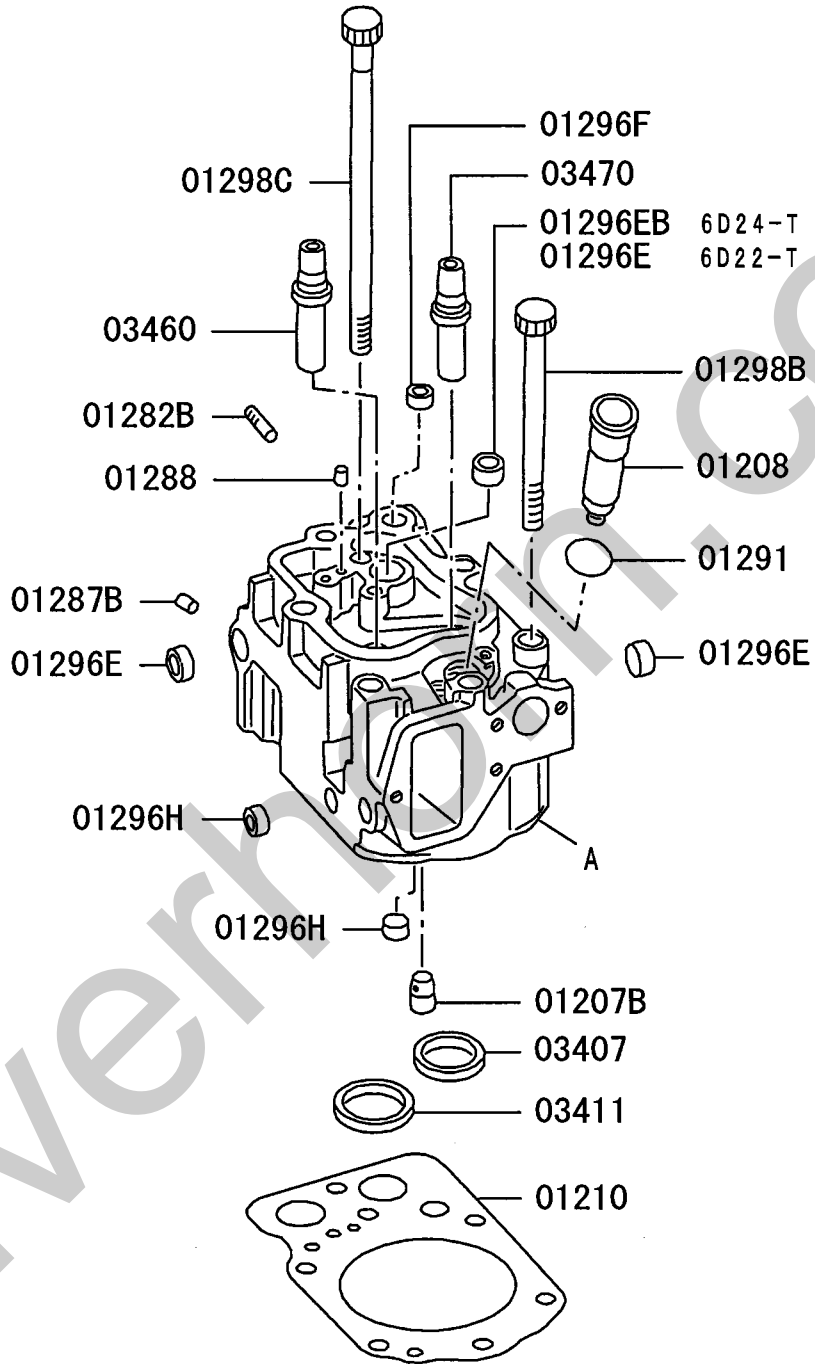

A: CYLINDER HEAD REF. 11-030

217T01

11 -120 CYLINDER HEAD

04 6D240 CTJS04US1
 03 6D240 CTJS04000
 02 6D221 CTJS12131 COLD
 01 6D221 CTJS12000 STD

-17-

見出番号 REF.-NO.	部品番号 PART NO.	代 替 R / P	変 更 順 号 S C E N E Q G	部品名称および記事・仕様記号 PART NAME & DESCRIPTION	型式・個数 MODEL & QTY					適用号機 APPLICABLE SERIAL NO.	管 区 M / R	新 規 V R D
					0	1	2	3	4			
01207B	ME062523			DIRECTOR,CYLINDER HEAD WATER	6	6	6	6				
01208	3090113709			TUBE,CYLINDER HEAD NOZZLE HOLDER	6	6	6	6				
01210	ME051618 (ME051714)	R		GASKET,CYLINDER HEAD	6	6				9006-1	9009-3	
	ME051714			GASKET,CYLINDER HEAD	6	6				9010-1		
	ME051714			GASKET,CYLINDER HEAD			6	6		9901-1		
01282B	MH002131			STUD,CYLINDER HEAD 10X43	24	24	24	24		9006-1		
01287B	MH037762			PLUG,CYLINDER HEAD 11	6	6	6	6		9006-1		
01288	MF472585			SPRING PIN,CYLINDER HEAD 6X12	6	6	6	6		9006-1		
01291	MH035157			O-RING,CYLINDER HEAD 27	6	6	6	6		9006-1		
01296E	MS666137			CAP,CYLINDER HEAD SEALING,25	18	18				9006-1		
	MS666137			CAP,CYLINDER HEAD SEALING,25			12	12		9901-1		
01296EB	MS666136			CAP,CYLINDER HEAD SEALING,D=22			6	6		9901-1		
01296F	MS666134			CAP,CYLINDER HEAD SEALING,18	6	6	6	6		9006-1		
01296H	MS666135			CAP,CYLINDER HEAD SEALING,20	12	12	12	12		9006-1		
01298B	ME051515			BOLT,CYLINDER HEAD FLANGE,14X181	36	36	36	36		9006-1		
01298C	ME051516			BOLT,CYLINDER HEAD FLANGE,14X249	6	6	6	6		9006-1		
03407	ME051354			SEAT,EXHAUST VALVE	6	6	6	6		9006-1		
03411	ME051300			SEAT,INLET VALVE	6	6	6	6		9006-1		
03460	ME051120			GUIDE,INLET VALVE	6	6	6	6		9006-1		
03470	ME051122			GUIDE,EXHAUST VALVE	6	6	6	6		9006-1		

シリンダブロック
11-130 CYLINDER BLOCK

-18-

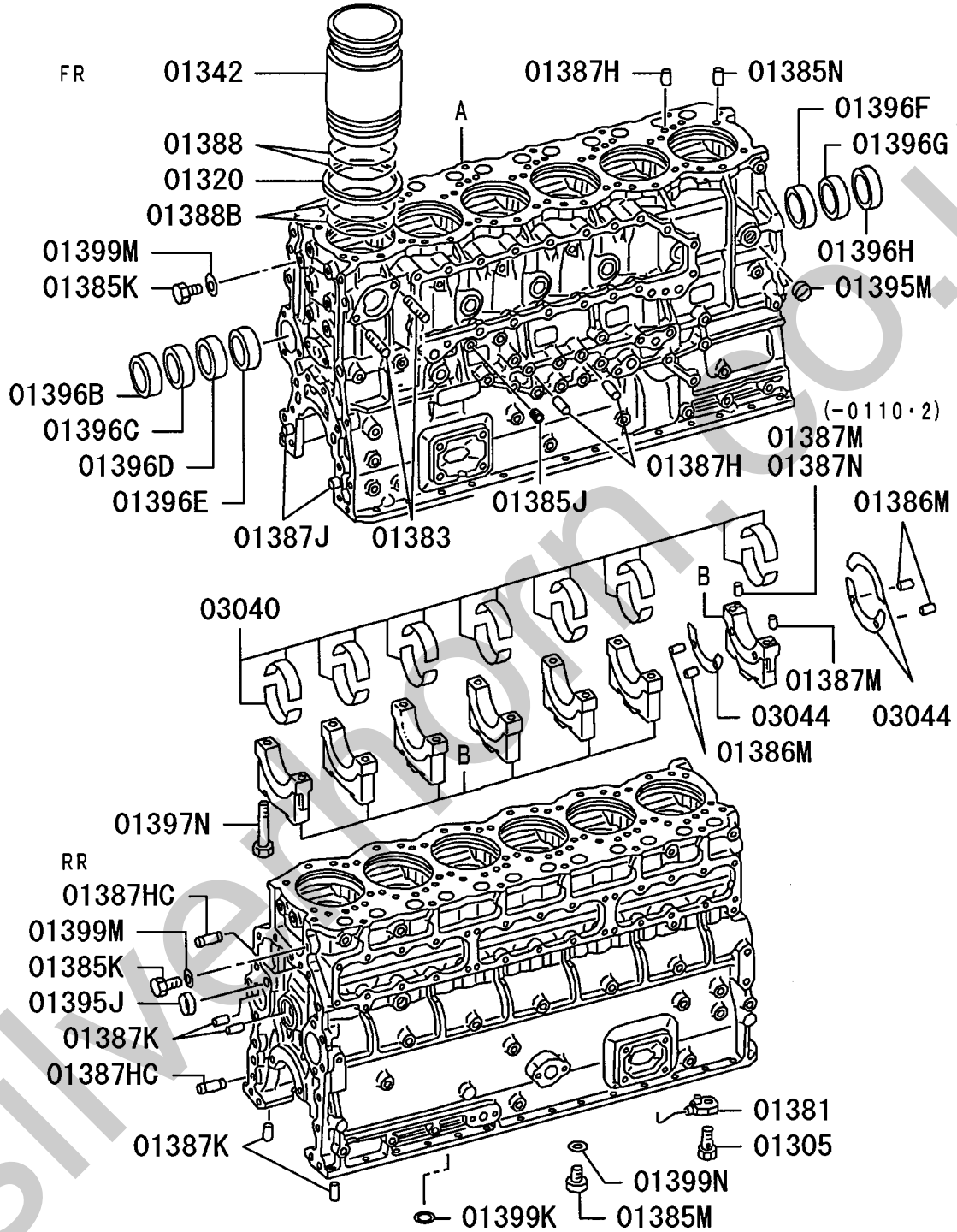

A: CYLINDER BLOCK REF. 11-040
B: BEARING CAP REF. 11-040

217T01

11 -130 CYLINDER BLOCK

シリンダブロック

04 6D240 CTJS04US1
 03 6D240 CTJS04000
 02 6D221 CTJS12131 COLD
 01 6D221 CTJS12000 STD

-19-

見出番号 REF.-NO.	部品番号 PART NO.	代 替 順 号 R / S / E N P Q G	部品名称および記事・仕様記号 PART NAME & DESCRIPTION	型式・個数 MODEL & QTY						適用号機 APPLICABLE SERIAL NO.		管 区 M / R	新 規 V R D	
				0	1	2	0	3	0	4	FROM@			@UPTO
01305	ME051712		CHECK VALVE,CYLINDER BLOCK PISTON LUBRIC	6	6							9006-1		
	ME153215		CHECK VALVE,CYLINDER BLOCK PISTON LUBRIC			6	6					9901-1		
01320	3090722300		SEAL,CYLINDER LINER	6	6	6	6					9006-1		
			RUBBER											
01342	ME051632		LINER,CYLINDER	6	6							9006-1		
			A SIZE											
	ME051633		LINER,CYLINDER	6	6							9006-1		
			B SIZE											
	ME051634		LINER,CYLINDER	6	6							9006-1		
			C SIZE											
	ME051632		LINER,CYLINDER			6	6					9901-1		
			A SIZE											
	ME051633		LINER,CYLINDER			6	6					9901-1		
			B SIZE											
	ME051634		LINER,CYLINDER			6	6					9901-1		
			C SIZE											
01381	ME051706		OIL JET,CYLINDER BLOCK	6	6							9006-1		
	ME150482		OIL JET,CYLINDER BLOCK			6	6					9901-1		
01383	F145010030		STUD,CYLINDER BLOCK	2	2	2	2					9006-1		
			10X30											
01385H	ME351466		PLUG,CYLINDER BLOCK	1	1	1	1					0304-1		
			24											
01385J	MH037725		PLUG,CYLINDER BLOCK	1	1							9501-1	0203-3	
			TAPER,1/8											
	MH037788		PLUG,CYLINDER BLOCK	1	1							0304-1		
			TAPER,1/8											
	MH037725		PLUG,CYLINDER BLOCK			1	1					9901-1	9908-3	
			TAPER,1/8											
	MH037725		PLUG,CYLINDER BLOCK			2	2					9909-1	9912-2	
			TAPER,1/8											
	MH037725		PLUG,CYLINDER BLOCK			1	1					9912-3	0203-3	
			TAPER,1/8											
	MH037788		PLUG,CYLINDER BLOCK			1	1					0204-1		
			TAPER,1/8											
01385K	ME031088		PLUG,CYLINDER BLOCK	2	2	2	2					9006-1		
			SCREW,10											
01385M	MH037137		PLUG,CYLINDER BLOCK	2	2							9006-1	0303-3	
			SCREW,20											
	MH037137		PLUG,CYLINDER BLOCK	1	1							0304-1		
			SCREW,20											
	MH037137		PLUG,CYLINDER BLOCK			2	2					9901-1	0303-3	
			SCREW,20											
	MH037137		PLUG,CYLINDER BLOCK			1	1					0304-1		
			SCREW,20											
01385N	3090702800		PLUG,CYLINDER BLOCK	1	1	1	1					9006-1		
			10											
01386M	MH012037		SPRING PIN,CYLINDER BLOCK	6	6	6	6					9006-1		
			5X10											
01387H	MF472405		PIN,CYLINDER BLOCK	14	14	14	14					9006-1		
			DOWEL,10X20											

11 -130 CYLINDER BLOCK

04 6D240 CTJS04US1
 03 6D240 CTJS04000
 02 6D221 CTJS12131 COLD
 01 6D221 CTJS12000 STD

-20-

見出番号 REF.-NO.	部品番号 PART NO.	代 替 R / P	変 更 順 号 S C E N E Q G	部品名称および記事・仕様記号 PART NAME & DESCRIPTION	型式・個数 MODEL & QTY				適用号機 APPLICABLE SERIAL NO.		管 区 M / R	新 規 V R D
					0	1	2	3	4	FROM@		
01387HC	MH007011			PIN,CYLINDER BLOCK DOWEL,12X34	2	2	2	2		9006-1		
01387J	MF472406			PIN,CYLINDER BLOCK DOWEL,12X24	2	2	2	2		9006-1		
01387K	MF472404			PIN,CYLINDER BLOCK DOWEL,8X18	4	4	4	4		9006-1		
01387M	MH007009			PIN,CYLINDER BLOCK DOWEL,8X25	2	2				9006-1	0110-2	
	MH007009			PIN,CYLINDER BLOCK DOWEL,8X25	1	1				0110-3		
	MH007009			PIN,CYLINDER BLOCK DOWEL,8X25			2	2		9901-1	0110-2	
	MH007009			PIN,CYLINDER BLOCK DOWEL,8X25			1	1		0110-3		
01387N	MH007008			PIN,CYLINDER BLOCK DOWEL,8X25	1	1	1	1		0110-3		
01388	ME151038	3		O-RING,CYLINDER BLOCK 142	12	12				9006-1	9407-3	
	(ME153319) ME051375	R		O-RING,CYLINDER BLOCK 142	12	12				9006-1	9412-3	
	(ME151038) ME151038	3		O-RING,CYLINDER BLOCK 142	24	24				9408-1	9909-3	
	(ME153319) ME153319			O-RING,CYLINDER BLOCK 142	12	12				9910-1		
	ME151038	3		O-RING,CYLINDER BLOCK 142			12	12		9901-1	9908-3	
	(ME153319) ME153319			O-RING,CYLINDER BLOCK 142			12	12		9909-1		
01388B	3110702401	R		O-RING,CYLINDER BLOCK 138	12	12				9006-1	9407-3	
	(ME151039) ME151039			O-RING,CYLINDER BLOCK 138	24	24				9408-1	9412-3	
	ME151039			O-RING,CYLINDER BLOCK 138	12	12				9501-1		
	ME151039			O-RING,CYLINDER BLOCK 138			12	12		9901-1		
01395J	F501428000			CAP,CYLINDER BLOCK SEALING,28	1	1	1	1		9006-1		
01395M	MS666137			CAP,CYLINDER BLOCK SEALING,25	1	1	1	1		9006-1		
01396B	ME051672			BUSHING,CYLINDER BLOCK	1	1	1	1		9006-1		
01396C	ME051673			BUSHING,CYLINDER BLOCK	1	1	1	1		9006-1		
01396D	ME051674			BUSHING,CYLINDER BLOCK	1	1	1	1		9006-1		
01396E	ME051675			BUSHING,CYLINDER BLOCK	1	1	1	1		9006-1		
01396F	ME051676			BUSHING,CYLINDER BLOCK	1	1	1	1		9006-1		

11 -130 シリンダブロック CYLINDER BLOCK

04 6D240 CTJS04US1
 03 6D240 CTJS04000
 02 6D221 CTJS12131 COLD
 01 6D221 CTJS12000 STD

-21-

見出番号 REF.-NO.	部品番号 PART NO.	代 替 R / P	変 更 順 号 S C E N E / O G	部品名称および記事・仕様記号 PART NAME & DESCRIPTION	型式・個数 MODEL & QTY							適用号機 APPLICABLE SERIAL NO.		管 区 M / R	新 規 V R D	
					0	1	2	3	4	5	6	7	FROM@			@UPTO
01396G	ME051677			BUSHING,CYLINDER BLOCK	1	1	1	1					9006-1			
01396H	ME051678			BUSHING,CYLINDER BLOCK	1	1	1	1					9006-1			
01397N	ME061330			BOLT,CYLINDER BLOCK FLANGE,18X136	14	14							9006-1	9908-3		
	ME180041			BOLT,CYLINDER BLOCK 18X154	14	14							9909-1			
	ME061330			BOLT,CYLINDER BLOCK FLANGE,18X136				14	14				9901-1	9908-3		
	ME180041			BOLT,CYLINDER BLOCK 18X154				14	14				9909-1			
01399K	ME351484			GASKET,CYLINDER BLOCK 24	1	1	1	1					0304-1			
01399M	F420210000			GASKET,CYLINDER BLOCK 10	2	2	2	2					9006-1			
01399N	MH035077			GASKET,CYLINDER BLOCK 20	2	2							9006-1	0303-3		
	MH035077			GASKET,CYLINDER BLOCK 20	1	1							0304-1			
	MH035077			GASKET,CYLINDER BLOCK 20				2	2				9901-1	0303-3		
	MH035077			GASKET,CYLINDER BLOCK 20				1	1				0304-1			
03040	ME052053	3		BEARING SET,CRANKSHAFT PLAIN,STD	1	1							9006-1	9912-2		
	(ME996661) ME052054	3		BEARING SET,CRANKSHAFT PLAIN,U/SIZE 0.25	1	1							9006-1	9912-2		
	(ME996662) ME052055	3		BEARING SET,CRANKSHAFT PLAIN,U/SIZE 0.50	1	1							9006-1	9912-2		
	(ME996663) ME052056			BEARING SET,CRANKSHAFT PLAIN,U/SIZE 0.75	1	1							9006-1	9912-2		
	ME052057	3		BEARING SET,CRANKSHAFT PLAIN,U/SIZE 1.00	1	1							9006-1	9912-2		
	(ME996665) ME181323	3		BEARING SET,CRANKSHAFT PLAIN,STD	1	1							9912-3	0010-1		
	(ME350864) ME181324	3		BEARING SET,CRANKSHAFT PLAIN,U/SIZE 0.25	1	1							9912-3	0010-1		
	(ME350865) ME181325	3		BEARING SET,CRANKSHAFT PLAIN,U/SIZE 0.50	1	1							9912-3	0010-1		
	(ME350866) ME181326	3		BEARING SET,CRANKSHAFT PLAIN,U/SIZE 0.75	1	1							9912-3	0010-1		
	(ME350867) ME181327	3		BEARING SET,CRANKSHAFT PLAIN,U/SIZE 1.00	1	1							9912-3	0010-1		

11 -130 シリンダブロック CYLINDER BLOCK

04 6D240 CTJS04US1
 03 6D240 CTJS04000
 02 6D221 CTJS12131 COLD
 01 6D221 CTJS12000 STD

-22-

見出番号 REF.-NO.	部品番号 PART NO.	代 替 順 号 R / P	変 記 順 号 S C E N E Q G	部品名称および記事・仕様記号 PART NAME & DESCRIPTION	型式・個数 MODEL & QTY						適用号機 APPLICABLE SERIAL NO.		管 区 M / R	新 規 V R D
					0	1	2	3	4		FROM@	@UPTO		
	(ME350868) ME350864			BEARING SET,CRANKSHAFT PLAIN,STD	1	1						0010-2		
	ME350865			BEARING SET,CRANKSHAFT PLAIN,U/SIZE 0.25	1	1						0010-2		
	ME350866			BEARING SET,CRANKSHAFT PLAIN,U/SIZE 0.50	1	1						0010-2		
	ME350867			BEARING SET,CRANKSHAFT PLAIN,U/SIZE 0.75	1	1						0010-2		
	ME350868			BEARING SET,CRANKSHAFT PLAIN,U/SIZE 1.00	1	1						0010-2		
	ME052053	3		BEARING SET,CRANKSHAFT PLAIN,STD			1	1				9901-1	9912-2	
	(ME996661) ME052054	3		BEARING SET,CRANKSHAFT PLAIN,U/SIZE 0.25			1	1				9901-1	9912-2	
	(ME996662) ME052055	3		BEARING SET,CRANKSHAFT PLAIN,U/SIZE 0.50			1	1				9901-1	9912-2	
	(ME996663) ME052056			BEARING SET,CRANKSHAFT PLAIN,U/SIZE 0.75			1	1				9901-1	9912-2	
	ME052057	3		BEARING SET,CRANKSHAFT PLAIN,U/SIZE 1.00			1	1				9901-1	9912-2	
	(ME996665) ME181323	3		BEARING SET,CRANKSHAFT PLAIN,STD			1	1				9912-3	0010-1	
	(ME350864) ME181324	3		BEARING SET,CRANKSHAFT PLAIN,U/SIZE 0.25			1	1				9912-3	0010-1	
	(ME350865) ME181325	3		BEARING SET,CRANKSHAFT PLAIN,U/SIZE 0.50			1	1				9912-3	0010-1	
	(ME350866) ME181326	3		BEARING SET,CRANKSHAFT PLAIN,U/SIZE 0.75			1	1				9912-3	0010-1	
	(ME350867) ME181327	3		BEARING SET,CRANKSHAFT PLAIN,U/SIZE 1.00			1	1				9912-3	0010-1	
	(ME350868) ME350864			BEARING SET,CRANKSHAFT PLAIN,STD			1	1				0010-2		
	ME350865			BEARING SET,CRANKSHAFT PLAIN,U/SIZE 0.25			1	1				0010-2		
	ME350866			BEARING SET,CRANKSHAFT PLAIN,U/SIZE 0.50			1	1				0010-2		
	ME350867			BEARING SET,CRANKSHAFT PLAIN,U/SIZE 0.75			1	1				0010-2		
	ME350868			BEARING SET,CRANKSHAFT PLAIN,U/SIZE 1.00			1	1				0010-2		

11 -140 OIL PAN, FILLER & GAUGE

-24-

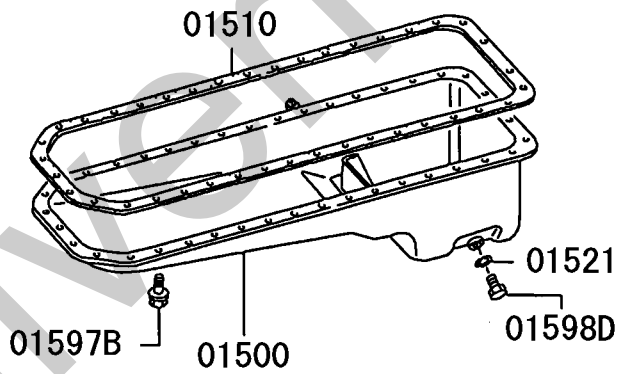
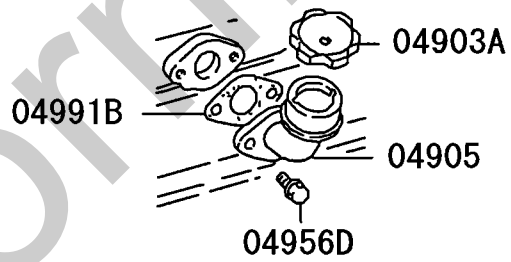
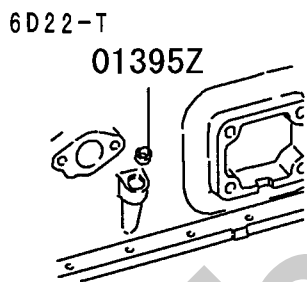
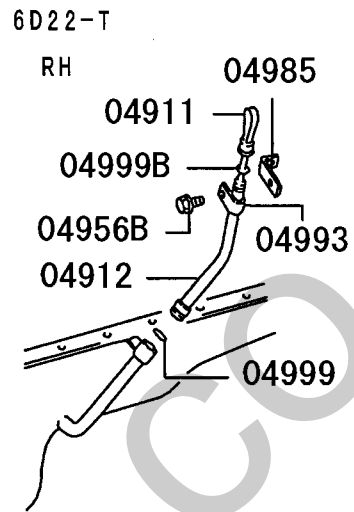
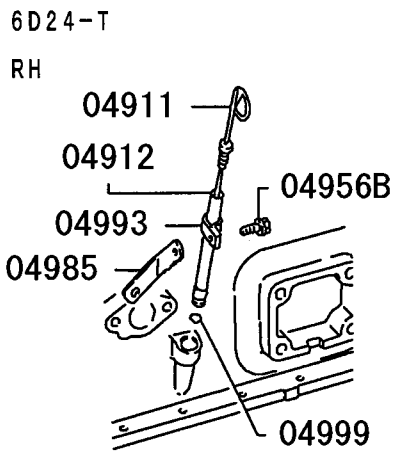

217T01

11 -140 OIL PAN,FILLER & GAUGE

オイルパン、フィルラ & ゲージ

04 6D240 CTJS04US1
 03 6D240 CTJS04000
 02 6D221 CTJS12131 COLD
 01 6D221 CTJS12000 STD

-25-

見出番号 REF.-NO.	部品番号 PART NO.	代 替 R / P	記 順 号 S C E N O G	部品名称および記事・仕様記号 PART NAME & DESCRIPTION	型式・個数 MODEL & QTY						適用号機 APPLICABLE SERIAL NO.		管 区 M / R	新 規 V R D
					0	1	2	3	4	FROM@	@UPTO			
01395Z	MH037760			CAP,CYLINDER BLOCK SEALING,D=15	1	1						9006-1		
01500	ME058198			OIL PAN,ENG	1	1						9006-1		
	ME158178			OIL PAN,ENG			1	1				9901-1		
01510	ME052497	R		GASKET,ENG OIL PAN	1	1						9006-1	9412-3	
	(ME150050)													
	ME150050	R		GASKET,ENG OIL PAN	1	1						9501-1	9607-3	
	(ME152344)													
	ME152344			GASKET,ENG OIL PAN	1	1						9608-1		
	ME152344			GASKET,ENG OIL PAN			1	1				9901-1		
01521	MH035018			GASKET,ENG OIL PAN DRAIN PLUG 18	1	1	1	1				9006-1		
01597B	MH000931			BOLT,ENG OIL PAN FLANGE,10X18	37	37						9006-1	0206-3	
	MF303363			BOLT,ENG OIL PAN	2	2						9006-1	0206-3	
				WASHER ASSEMBLED,10X25										
	MS146003			BOLT,ENG OIL PAN FLANGE,10X18	37	37						0207-1		
	MH001785			BOLT,ENG OIL PAN 10X25	2	2						0207-1		
	MH000931			BOLT,ENG OIL PAN FLANGE,10X18			37	37				9901-1	0206-3	
	MF303363			BOLT,ENG OIL PAN			2	2				9901-1	0206-3	
				WASHER ASSEMBLED,10X25										
	MS146003			BOLT,ENG OIL PAN FLANGE,10X18			37	37				0207-1		
	MH001785			BOLT,ENG OIL PAN 10X25			2	2				0207-1		
01598D	MH037126			PLUG,ENG OIL PAN SCREW,18	1	1	1	1				9006-1		
04903A	MD008784 (MD132260)	3		CAP ASSY,ENG OIL FILLER	1	1	1	1				9006-1		
04905	ME058900			FILLER,ENG OIL	1	1	1	1				9006-1		
04911	MH093016			GAUGE,ENG OIL LEVEL	1	1						9006-1		
	ME158181			GAUGE,ENG OIL LEVEL			1	1				9901-1		
04912	ME058934			GUIDE,ENG OIL LEVEL GAUGE	1	1						9006-1		
	ME157032			GUIDE,ENG OIL LEVEL GAUGE			1	1				9901-1		
04956B	MH000999			BOLT,ENG OIL FILLER FLANGE,6X12	1	1	1	1				9006-1		
04956D	MH000713	#		BOLT,ENG OIL FILLER FLANGE,10X20 T02406A	2	2						9006-1	9910-2	
	MS146004			BOLT,ENG OIL FILLER FLANGE,10X20	2	2						9910-3		
	MH000713	#		BOLT,ENG OIL FILLER FLANGE,10X20 T02406A			2	2				9901-1	9910-2	
	MS146004			BOLT,ENG OIL FILLER FLANGE,10X20			2	2				9910-3		
04985	ME930089			STAY,ENG OIL FILLER	1	1						9006-1		
	MH023799			STAY,ENG OIL FILLER			1	1				9901-1		
04991B	MH035087	3		GASKET,ENG OIL FILLER	1	1						9006-1	9412-3	

11 -140 OIL PAN,FILLER & GAUGE

オイルパン、フィラ & ゲージ

04 6D240 CTJS04US1
 03 6D240 CTJS04000
 02 6D221 CTJS12131 COLD
 01 6D221 CTJS12000 STD

-26-

見出番号 REF.-NO.	部品番号 PART NO.	代 替 R / P	記 号 S C E N P Q G	部品名称および記事・仕様記号 PART NAME & DESCRIPTION	型式・個数 MODEL & QTY					適用号機 APPLICABLE SERIAL NO. FROM@- @UPTO	管 区 M / R	新 規 V R D	
					0	1	2	3	4				
04993	(ME150060) ME150060			GASKET,ENG OIL FILLER	1	1					9501-1		
	ME150060			GASKET,ENG OIL FILLER			1	1			9901-1		
	MH021015			CLAMP,ENG OIL FILLER D=12.2	1	1	1	1			9006-1		
04999	F315001100			O-RING,ENG OIL FILLER 11	1	1					9006-1		
	MH035225	3		O-RING,ENG OIL FILLER 11			1	1			9901-1	0209-3	
04999B	(MH035242) MH035242			O-RING,ENG OIL FILLER 10.8			1	1			0210-1		
	F315001000			O-RING,ENG OIL FILLER 10	1	1					9006-1		

11 -150 FLYWHEEL & HOUSING

フライホイール & ハウジング

-28-

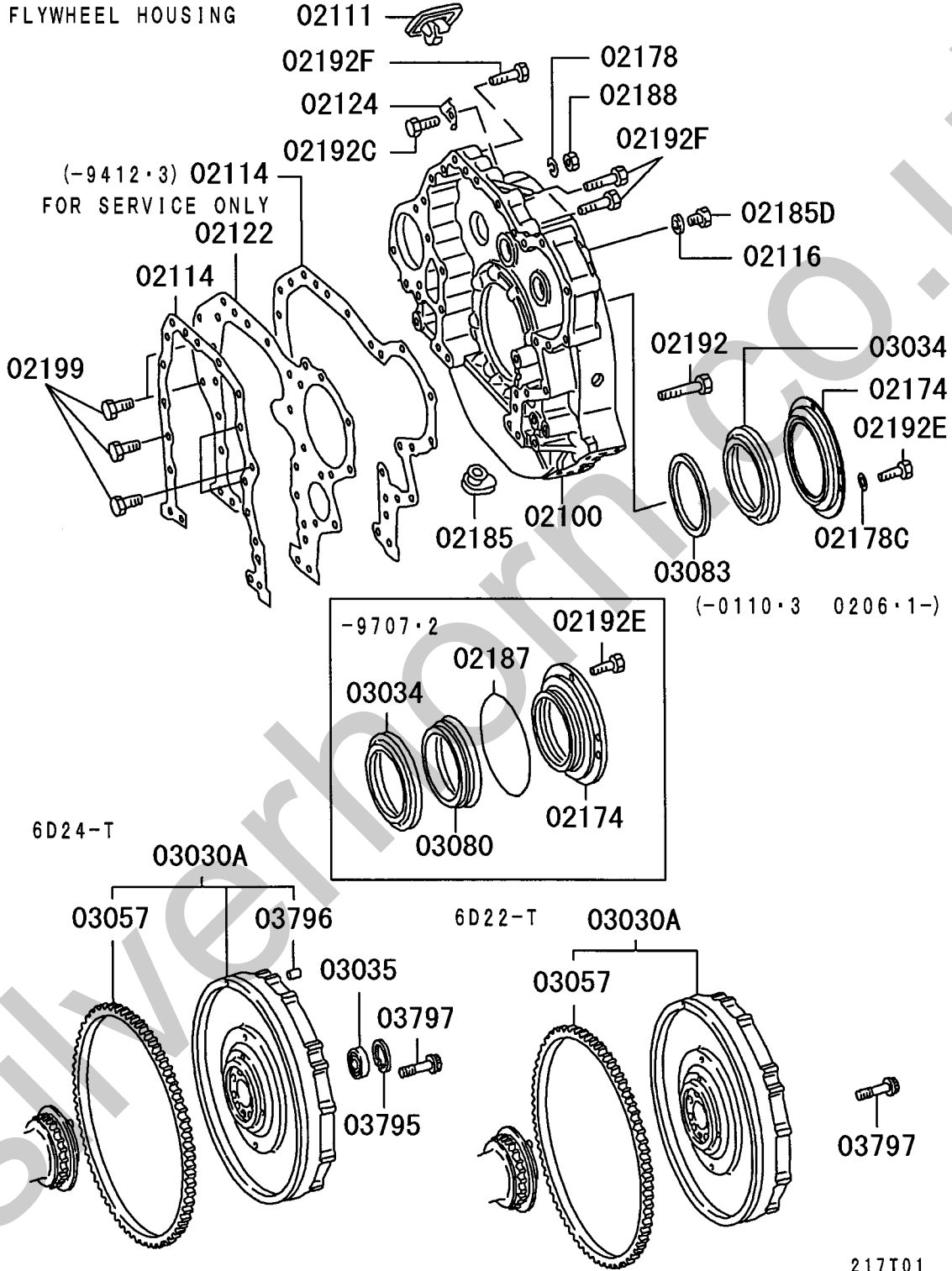

TACHOMETER DRIVE

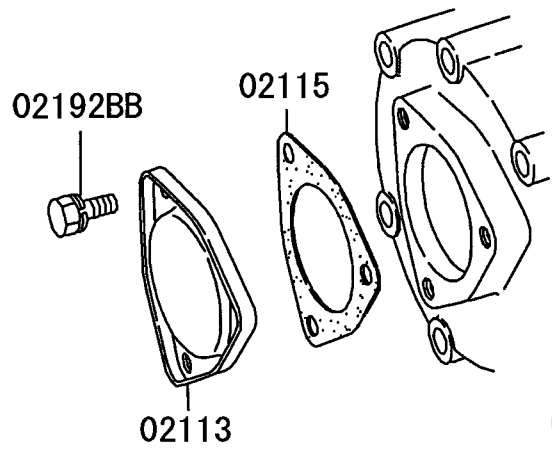

11 -150 FLYWHEEL & HOUSING

フライホイール & ハウジング

04 6D240 CTJS04US1
 03 6D240 CTJS04000
 02 6D221 CTJS12131 COLD
 01 6D221 CTJS12000 STD

-30-

見出番号 REF.-NO.	部品番号 PART NO.	代 替 R / P	記 順 号 S C E N E Q G	部品名称および記事・仕様記号 PART NAME & DESCRIPTION	型式・個数 MODEL & QTY						適用号機 APPLICABLE SERIAL NO.		管 区 M / R	新 規 V R D	
					0	1	0	2	0	3	0	4			FROM@
02100	ME052816 (ME150257)	3		HOUSING,FLYWHEEL	1	1						9006-1	9108-3		
	ME150316 (ME151085)	3		HOUSING,FLYWHEEL	1	1						9109-1	9404-3		
	ME151085 (ME152617)	3		HOUSING,FLYWHEEL	1	1						9405-1	9701-3		
	ME152225 (ME152602)	3		HOUSING,FLYWHEEL	1	1						9702-1	9707-2		
	ME152602			HOUSING,FLYWHEEL	1	1						9707-3			
	ME152602			HOUSING,FLYWHEEL			1	1				9901-1			
02111	3121202300 (ME151267)	R		COVER,FLYWHEEL HOUSING TIMING POINTER	1	1						9006-1	0109-3		
	ME151267			COVER,FLYWHEEL HOUSING TIMING POINTER	1	1						0110-1			
	3121202300 (ME151267)	R		COVER,FLYWHEEL HOUSING TIMING POINTER			1	1				9901-1	0109-3		
	ME151267			COVER,FLYWHEEL HOUSING TIMING POINTER			1	1				0110-1			
02113	3111204100			COVER,FLYWHEEL HOUSING,RR	1	1	1	1				9006-1			
02114	ME052671 (ME150048)	R		GASKET,ENG RR PLATE CYLINDER BLOCKSIDE	1	1						9006-1	9412-3		
	ME052672 (ME150049)	3		GASKET,ENG RR PLATE FLYWHEEL HOUSING SIDE	1	1						9006-1	9412-3		
	ME150048			GASKET,ENG RR PLATE CYLINDER BLOCKSIDE	1	1						9501-1			
	ME150048			GASKET,ENG RR PLATE CYLINDER BLOCKSIDE			1	1				9901-1			
02115	3111204200			GASKET,FLYWHEEL HOUSING RR COVER	1	1	1	1				9006-1			
02116	F420216000			GASKET,FLYWHEEL HOUSING 16	1	1	1	1				9006-1			
02122	ME052661			PLATE,CYLINDER BLOCK,RR	1	1	1	1				9006-1			
02124	ME061699			POINTER,FLYWHEEL HOUSING ENG TIMING	1	1	1	1				9006-1			
02174	ME052550 (ME090430)	3		RETAINER,FLYWHEEL HOUSING OIL SEAL	1	1						9006-1	9206-3		
	ME090430			RETAINER,FLYWHEEL HOUSING OIL SEAL	1	1						9207-1	9707-2		
	ME152593			RETAINER,FLYWHEEL HOUSING OIL SEAL	1	1						9707-3			
	ME152584			RETAINER,FLYWHEEL HOUSING OIL SEAL			1	1				9901-1			
02178	F251506000			WASHER,FLYWHEEL HOUSING SPRING,6	1	1	1	1				9006-1			
02178C	F250008000			WASHER,FLYWHEEL HOUSING PLAIN,8	4	4	4	4				9707-3			
02185	3091201400			PLUG,FLYWHEEL HOUSING RUBBER,29	1	1	1	1				9006-1			
02185D	M0001300			PLUG,FLYWHEEL HOUSING SCREW,16	1	1	1	1				9006-1			
02187	3111203902			O-RING,FLYWHEEL HOUSING 179	1	1						9006-1	9707-2		
02188	F230006000			NUT,FLYWHEEL HOUSING 6	1	1	1	1				9006-1			
02192	MH000927			BOLT,FLYWHEEL HOUSING	8	8						9006-1	9910-2		

11 -150 FLYWHEEL & HOUSING

フライホイール & ハウジング

04 6D240 CTJS04US1
 03 6D240 CTJS04000
 02 6D221 CTJS12131 COLD
 01 6D221 CTJS12000 STD

-31-

見出番号 REF.-NO.	部品番号 PART NO.	代 替 順 号 R / S C E N E P O G	部品名称および記事・仕様記号 PART NAME & DESCRIPTION	型式・個数 MODEL & QTY					適用号機 APPLICABLE SERIAL NO.		管 区 M / R	新 規 V R D	
				0	1	2	3	4	FROM@	@UPTO			
	MS146065		FLANGE,12X90	8		8					9910-3		
	MH000927		BOLT,FLYWHEEL HOUSING FLANGE,12X90				8	8			9901-1	9910-2	
	MS146065		BOLT,FLYWHEEL HOUSING FLANGE,12X90				8	8			9910-3		
02192BB	MF300841		BOLT,FLYWHEEL HOUSING WASHER ASSEMBLED,10X20	3	3	3	3				9006-1		
02192C	F102506025		BOLT,FLYWHEEL HOUSING 6X25	1	1	1	1				9006-1		
02192E	MF243649		BOLT,FLYWHEEL HOUSING WASHER ASSEMBLED,8X16	4	4						9006-1	9707-2	
	MF240050		BOLT,FLYWHEEL HOUSING WASHER ASSEMBLED,8X14	4	4						9707-3		
	MF240050		BOLT,FLYWHEEL HOUSING WASHER ASSEMBLED,8X14				4	4			9901-1		
02192F	MH000925		BOLT,FLYWHEEL HOUSING FLANGE,12X60	5	5						9006-1	9910-2	
	MS146059		BOLT,FLYWHEEL HOUSING FLANGE,12X60	5	5						9910-3		
	MH000925		BOLT,FLYWHEEL HOUSING FLANGE,12X60				5	5			9901-1	9910-2	
	MS146059		BOLT,FLYWHEEL HOUSING FLANGE,12X60				5	5			9910-3		
02199	MH000733		BOLT,ENG RR PLATE FLANGE,12X20	9	9						9006-1	0209-3	
	MS146051		BOLT,ENG RR PLATE 12X20	9	9						9907-1		
	MH000733		BOLT,ENG RR PLATE FLANGE,12X20				9	9			9901-1	0209-3	
	MS146051		BOLT,ENG RR PLATE 12X20				9	9			9907-1		
03030A	ME058037		FLYWHEEL ASSY	1	1						9006-1		
	ME150497	3	FLYWHEEL ASSY				1	1			9901-1		
03034	3092020100	#	OIL SLINGER,CRANKSHAFT,RR T02468A	1	1						9006-1	0108-2	
	ME351469		OIL SLINGER,CRANKSHAFT,RR	1	1						0108-3	0110-3	
	3092020100	#	OIL SLINGER,CRANKSHAFT,RR T02468A	1	1						0111-1	0205-3	
	ME351469		OIL SLINGER,CRANKSHAFT,RR	1	1						0206-1		
	3092020100	#	OIL SLINGER,CRANKSHAFT,RR T02468A				1	1			9901-1	0108-2	
	ME351469		OIL SLINGER,CRANKSHAFT,RR				1	1			0108-3	0110-3	
	3092020100	#	OIL SLINGER,CRANKSHAFT,RR T02468A				1	1			0111-1	0205-3	
03035	ME351469		OIL SLINGER,CRANKSHAFT,RR				1	1			0206-1		
	MH040026		BEARING,FLYWHEEL DRIVE PINION BALL				1	1			9901-1		

11 -150 FLYWHEEL & HOUSING

フライホイール & ハウジング

04 6D240 CTJS04US1
 03 6D240 CTJS04000
 02 6D221 CTJS12131 COLD
 01 6D221 CTJS12000 STD

-32-

見出番号 REF.-NO.	部品番号 PART NO.	代 替 順 号 R / P	記 号 S C E N E Q G	部品名称および記事・仕様記号 PART NAME & DESCRIPTION	型式・個数 MODEL & QTY						適用号機 APPLICABLE SERIAL NO.		管 区 M / R	新 規 V R D	
					0	1	2	3	4	5	FROM@-	@UPTO			
03057	ME062828			RING GEAR,FLYWHEEL N=143	1	1						9006-1	0202-3		
	ME351296			RING GEAR,FLYWHEEL N=143	1	1						0203-1			
	ME062828			RING GEAR,FLYWHEEL N=143			1	1				9901-1	0202-3		
	ME351296			RING GEAR,FLYWHEEL N=143			1	1				0203-1			
03080	3121233300			OIL SEAL,CRANKSHAFT,RR	1	1						9006-1	9707-2		
03083	ME351471 (ME351837)	3		RING,CRANKSHAFT RR OIL SLINGER	1	1	1	1				0108-3	0110-3		
03795	ME352391 F320206200			RING,CRANKSHAFT RR OIL SLINGER 62	1	1	1	1				0206-1			
03796	MF472405			SNAP RING,FLYWHEEL PIN,FLYWHEEL			2	2				9901-1			
03797	ME052691			DOWEL, 10X20 BOLT,FLYWHEEL FLANGE, 16X50.5	8	8	8	8				9006-1			

ピストン,コネクティングロッド & クランクシャフト
 11-210 PISTON, CONNROD & CRANKSHAFT

-34-

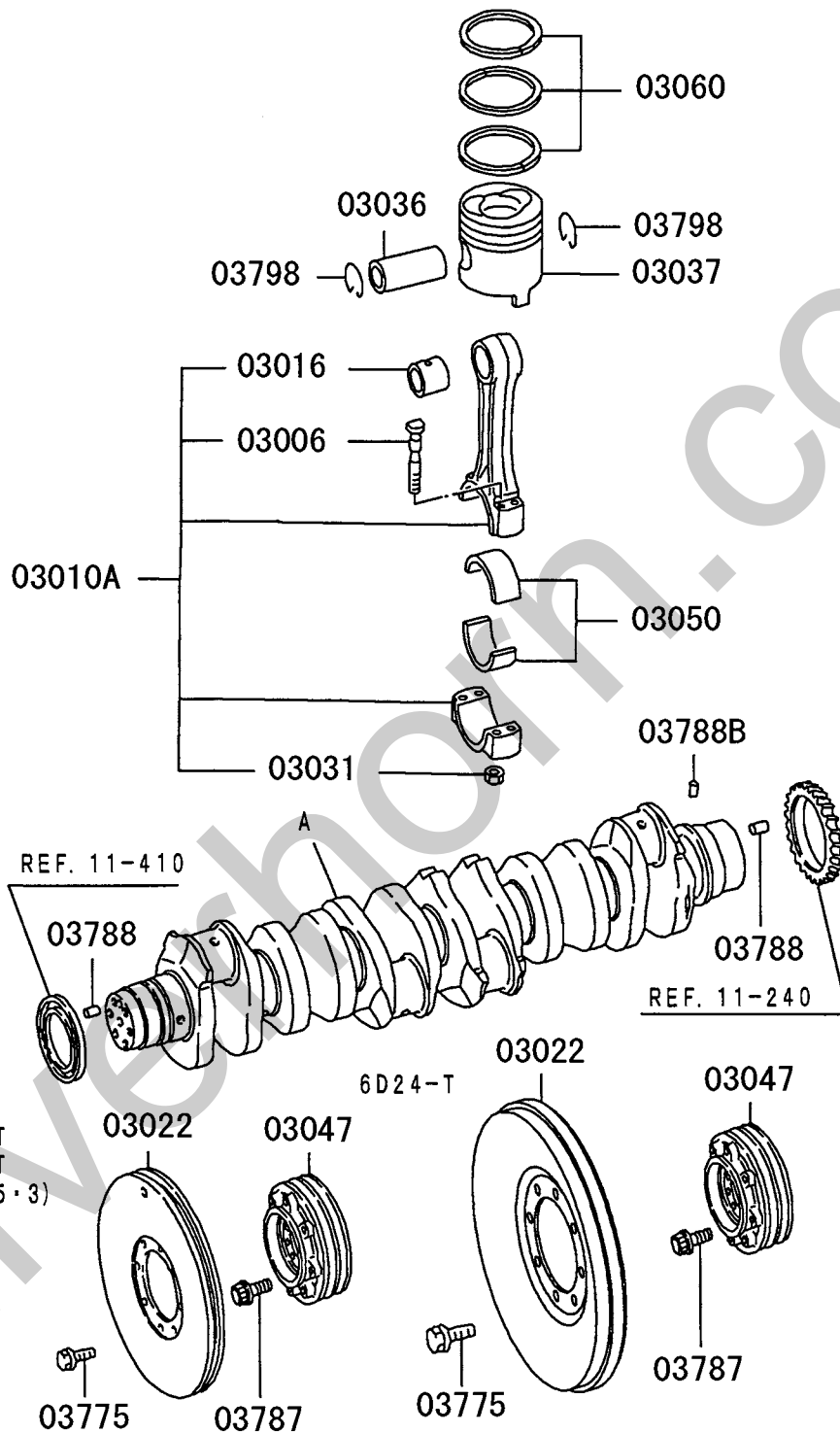

A: CRANKSHAFT REF. 11-060

217T01

ピストン、コネクティングロッド & クランクシャフト
11 -210 PISTON, CONNROD & CRANKSHAFT

04 6D240 CTJS04US1
03 6D240 CTJS04000
02 6D221 CTJS12131 COLD
01 6D221 CTJS12000 STD

-35-

見出番号 REF.-NO.	部品番号 PART NO.	代 替 # R / S C E N P O G	部品名称および記事・仕様記号 PART NAME & DESCRIPTION	型式・個数 MODEL & QTY				適用号機 APPLICABLE SERIAL NO.		管 区 M / R	新 規 V R D
				0	1	2	3	0	4		
03006	ME052765		BOLT, CONNROD 13X107	24	24	24	24			9006-1	
03010A	ME052763 (ME052825)	3	CONNECTING ROD ASSY	6	6					9006-1	9412-3
	ME150492 (ME150493)	3	CONNECTING ROD ASSY	6	6					9501-1	0012-2
	ME150493		CONNECTING ROD ASSY	6	6					0012-3	
	ME150493		CONNECTING ROD ASSY			6	6			9901-1	
03016	ME052660		BUSHING, CONNROD	6	6					9006-1	9412-3
	ME151450		BUSHING, CONNROD	6	6					9501-1	
	ME151450		BUSHING, CONNROD			6	6			9901-1	
03022	3092200102		DAMPER, CRANKSHAFT TORSIONAL	1	1					9006-1	
	ME121781 (ME121799)	3	DAMPER, CRANKSHAFT TORSIONAL			1	1			9901-1	9905-3
	ME121799	#	DAMPER, CRANKSHAFT TORSIONAL T02013			1	1			9906-1	
03031	ME032042		NUT, CONNROD FLANGE, 13	24	24	24	24			9006-1	
03036	ME052149		PIN, PISTON 50X106	6	6	6	6			9006-1	
03037	ME052668		PISTON O/SIZE 0.50	6	6					9006-1	
	ME052669		PISTON O/SIZE 0.75	6	6					9006-1	
	ME052670		PISTON O/SIZE 1.00	6	6					9006-1	
	ME052665		PISTON A SIZE	6	6					9006-1	
	ME052666		PISTON B SIZE	6	6					9006-1	
	ME052667		PISTON C SIZE	6	6					9006-1	
	ME158100		PISTON O/SIZE 0.50			6	6			9901-1	
	ME158101		PISTON O/SIZE 0.75			6	6			9901-1	
	ME158102		PISTON O/SIZE 1.00			6	6			9901-1	
	ME158097		PISTON A SIZE			6	6			9901-1	
	ME158098		PISTON B SIZE			6	6			9901-1	
	ME158099		PISTON C SIZE			6	6			9901-1	
03047	ME058316		PULLEY, CRANKSHAFT	1	1	1	1			9006-1	
03050	ME052488		BEARING SET, CONNROD PLAIN, STD	1	1					9006-1	9912-2
	ME052489		BEARING SET, CONNROD PLAIN, U/SIZE 0.25	1	1					9006-1	9912-2
	ME052490		BEARING SET, CONNROD	1	1					9006-1	9912-2

ピストン,コネクティングロッド & クランクシャフト
 11 -210 PISTON,CONNROD & CRANKSHAFT

04 6D240 CTJS04US1
 03 6D240 CTJS04000
 02 6D221 CTJS12131 COLD
 01 6D221 CTJS12000 STD

-36-

見出番号 REF.-NO.	部品番号 PART NO.	代 替 R / P	変 更 順 号 S C E N E Q G	部品名称および記事・仕様記号 PART NAME & DESCRIPTION	型式・個数 MODEL & QTY						適用号機 APPLICABLE SERIAL NO.		管 区 M / R	新 規 V R D	
					0	1	2	3	4		FROM@	@UPTO			
	ME052491			PLAIN,U/SIZE 0.50	1	1						9006-1	9912-2		
	ME052492			BEARING SET,CONNROD PLAIN,U/SIZE 0.75	1	1						9006-1	9912-2		
	ME181337			BEARING SET,CONNROD PLAIN,U/SIZE 1.00	1	1						9912-3			
	ME181338			BEARING SET,CONNROD STD	1	1						9912-3			
	ME181339			BEARING SET,CONNROD U/SIZE 0.25	1	1						9912-3			
	ME181340			BEARING SET,CONNROD U/SIZE 0.50	1	1						9912-3			
	ME181341			BEARING SET,CONNROD U/SIZE 0.75	1	1						9912-3			
	ME052488			BEARING SET,CONNROD U/SIZE 1.00				1	1			9901-1	9912-2		
	ME052489			BEARING SET,CONNROD PLAIN,STD				1	1			9901-1	9912-2		
	ME052490			BEARING SET,CONNROD PLAIN,U/SIZE 0.25				1	1			9901-1	9912-2		
	ME052491			BEARING SET,CONNROD PLAIN,U/SIZE 0.50				1	1			9901-1	9912-2		
	ME052492			BEARING SET,CONNROD PLAIN,U/SIZE 0.75				1	1			9901-1	9912-2		
	ME181337			BEARING SET,CONNROD PLAIN,U/SIZE 1.00				1	1			9912-3			
	ME181338			BEARING SET,CONNROD STD				1	1			9912-3			
	ME181339			BEARING SET,CONNROD U/SIZE 0.25				1	1			9912-3			
	ME181340			BEARING SET,CONNROD U/SIZE 0.50				1	1			9912-3			
	ME181341			BEARING SET,CONNROD U/SIZE 0.75				1	1			9912-3			
03060	ME052787	R		RING SET,PISTON U/SIZE 1.00	1	1						9006-1	9604-3		
	(ME995477) ME052788	R		RING SET,PISTON STD	1	1						9006-1	9604-3		
	(ME995478) ME052789	R		RING SET,PISTON O/SIZE 0.50	1	1						9006-1	9604-3		
	(ME995479) ME052790	R		RING SET,PISTON O/SIZE 0.75	1	1						9006-1	9604-3		
	(ME995480) ME995477			RING SET,PISTON O/SIZE 1.00	1	1						9605-1			
	ME995478			RING SET,PISTON STD	1	1						9605-1			

ピストン,コネクティングロッド & クランクシャフト
 11 -210 PISTON,CONNROD & CRANKSHAFT

04 6D240 CTJS04US1
 03 6D240 CTJS04000
 02 6D221 CTJS12131 COLD
 01 6D221 CTJS12000 STD

-37-

見出番号 REF.-NO.	部品番号 PART NO.	代 替 R / P	変 更 順 号 S C E N E Q G	部品名称および記事・仕様記号 PART NAME & DESCRIPTION	型式・個数 MODEL & QTY					適用号機 APPLICABLE SERIAL NO.		管 区 M / R	新 規 V R D
					0	1	2	3	4	FROM@	@UPTO		
	ME995479			O/SIZE 0.50 RING SET,PISTON	1	1					9605-1		
	ME995480			O/SIZE 0.75 RING SET,PISTON	1	1					9605-1		
	ME151190			O/SIZE 1.00 RING SET,PISTON STD			1	1			9901-1	0110-3	
	ME151191			RING SET,PISTON O/SIZE 0.50			1	1			9901-1	0110-3	
	ME151192			RING SET,PISTON O/SIZE 0.75			1	1			9901-1	0110-3	
	ME151193			RING SET,PISTON O/SIZE 1.00			1	1			9901-1	0110-3	
	ME350786			RING SET,PISTON STD			1	1			0111-1		
	ME350787			RING SET,PISTON O/SIZE 0.50			1	1			0111-1		
	ME350788			RING SET,PISTON O/SIZE 0.75			1	1			0111-1		
	ME350789			RING SET,PISTON O/SIZE 1.00			1	1			0111-1		
03775	MH000922			BOLT,TORSIONAL DAMPER FLANGE,12X16	8	8					9006-1	9910-2	
	MS146351			BOLT,TORSIONAL DAMPER	8	8					9910-3		
	MH000922			BOLT,TORSIONAL DAMPER FLANGE,12X16			8	8			9901-1	9910-2	
03787	MS146351			BOLT,TORSIONAL DAMPER			8	8			9910-3		
	MH000377			BOLT,CRANKSHAFT PULLEY FLANGE,14X33	6	6					9006-1	0207-3	
	ME352719			BOLT,CRANKSHAFT PULLEY	6	6					0208-1		
	MH000377			BOLT,CRANKSHAFT PULLEY FLANGE,14X33			6	6			9901-1	0207-3	
03788	ME352719			BOLT,CRANKSHAFT PULLEY			6	6			0208-1		
	MF472407			PIN,CRANKSHAFT DOWEL,14X28	2	2	2	2			9006-1		
03788B	MH012026			PIN,CRANKSHAFT DOWEL,5X11	1	1	1	1			9006-1		
03798	3121733100			SNAP RING,PISTON	12	12	12	12			9006-1		

11 -230 カムシャフト & バルブ CAMSHAFT & VALVE

-38-

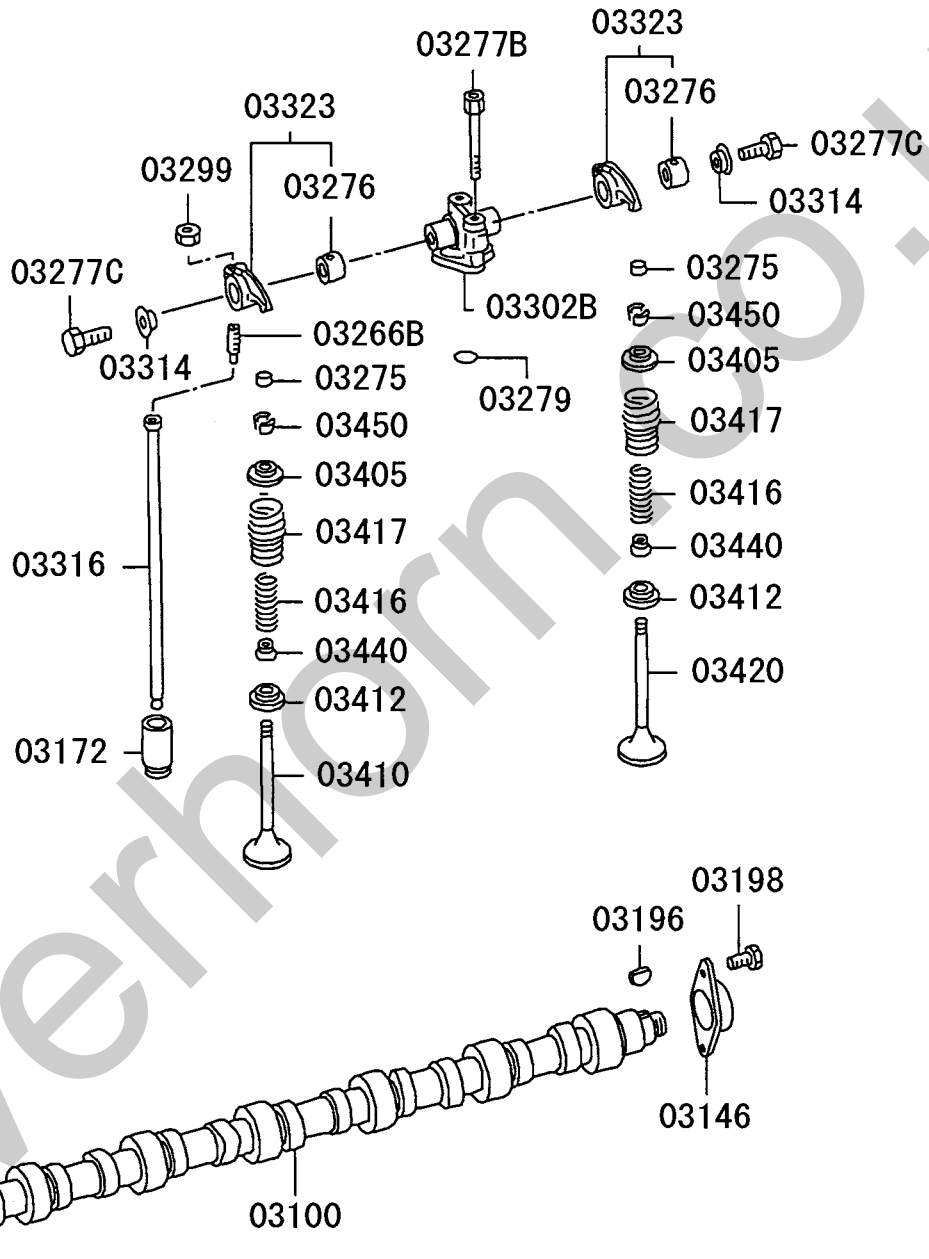

(-9605・3)

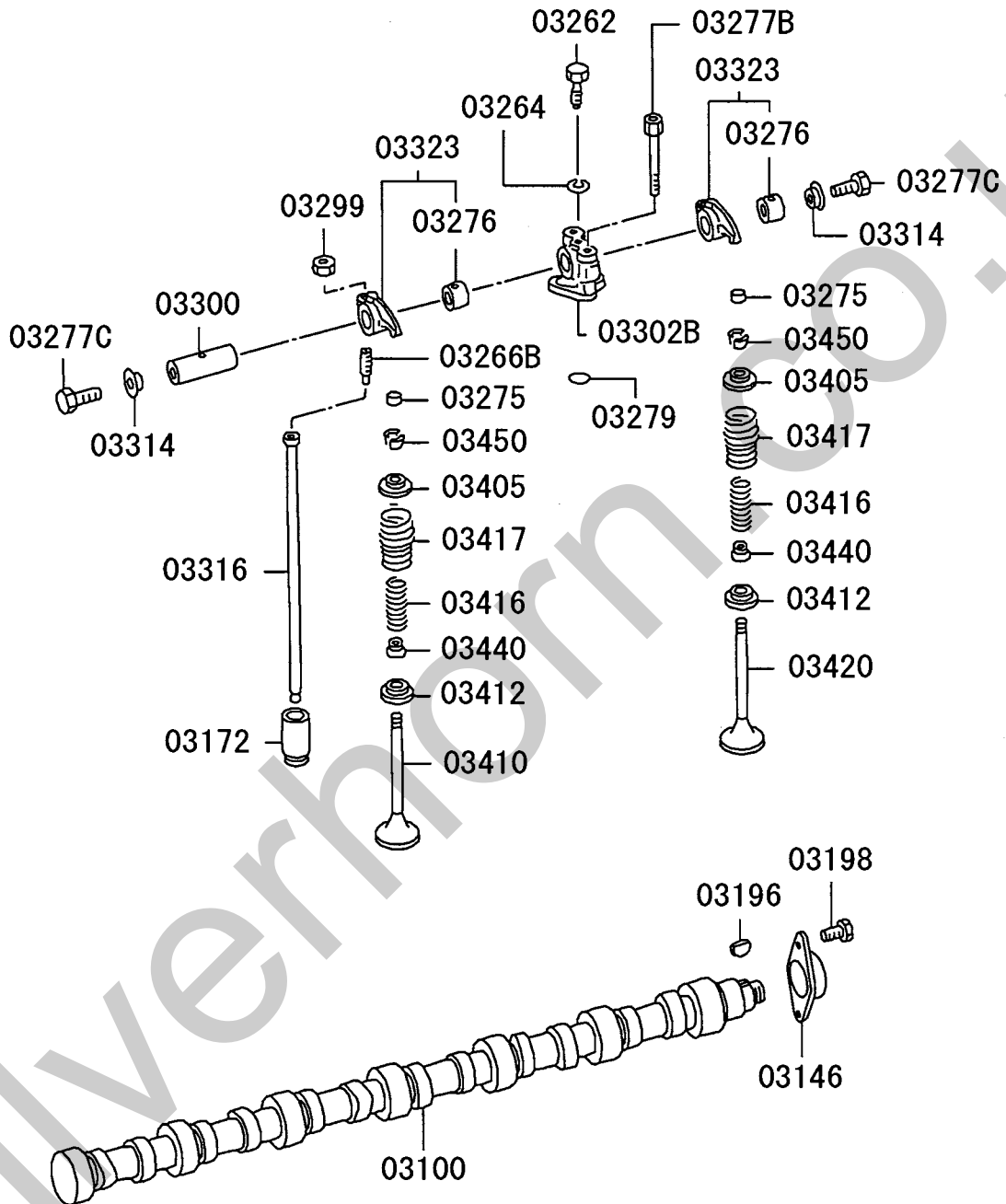

11 -230 CAMSHAFT & VALVE

04 6D240 CTJS04US1
 03 6D240 CTJS04000
 02 6D221 CTJS12131 COLD
 01 6D221 CTJS12000 STD

-40-

見出番号 REF.-NO.	部品番号 PART NO.	代 替 順 号 R / S C E N E P O G	部品名称および記事・仕様記号 PART NAME & DESCRIPTION	型式・個数 MODEL & QTY						適用号機 APPLICABLE SERIAL NO.		管 区 M / R	新 規 V R D
				0	1	2	3	4	FROM@	@UPTO			
				0	1	2	3	4					
03100	ME051209	#	CAMSHAFT T95042	1	1					9006-1	9502-3		
	ME151299		CAMSHAFT	1	1					9503-1			
	ME151299		CAMSHAFT			1	1			9901-1			
03146	3090510500	#	PLATE,CAMSHAFT THRUST T95042	1	1					9006-1	9502-3		
	ME151300		PLATE,CAMSHAFT THRUST	1	1					9503-1			
	ME151300		PLATE,CAMSHAFT THRUST			1	1			9901-1			
03172	ME061021		TAPPET,VALVE	12	12	12	12			9006-1			
03196	F287005019		KEY,CAMSHAFT WOODRUFF,5X19	1	1	1	1			9006-1			
03198	MH000714		BOLT,CAMSHAFT FLANGE,10X25	2	2					9006-1	0304-3		
	MS146306		BOLT,CAMSHAFT FLANGE,10X25	2	2					0305-1			
	MH000714		BOLT,CAMSHAFT FLANGE,10X25			2	2			9901-1	0304-3		
	MS146306		BOLT,CAMSHAFT FLANGE,10X25			2	2			0305-1			
03262	3090400900		SET SCREW,VALVE GEAR TRAIN 8X17	6	6					9006-1	9605-3		
03264	F251508000		WASHER,VALVE GEAR TRAIN SPRING,8	6	6					9006-1	9605-3		
03266B	ME051584	3	SCREW,VALVE GEAR TRAIN TAPPING,10X45	12	12					9006-1	0109-3		
	(ME351744) ME351744		SCREW,VALVE GEAR TRAIN 10X43	12	12					0110-1			
	ME051584	3	SCREW,VALVE GEAR TRAIN TAPPING,10X45			12	12			9901-1	0109-3		
	(ME351744) ME351744		SCREW,VALVE GEAR TRAIN 10X43			12	12			0110-1			
03275	3000424302		CAP,VALVE GEAR TRAIN 12	12	12	12	12			9006-1			
03276	3090402200		BUSHING,VALVE GEAR TRAIN	12	12	12	12			9006-1			
03277B	ME051702	R	BOLT,VALVE GEAR TRAIN 10X84	6	6					9006-1	9605-3		
	(ME152008) ME152008		BOLT,VALVE GEAR TRAIN 10X84	6	6					9606-1			
	ME152008		BOLT,VALVE GEAR TRAIN 10X84			6	6			9901-1			
03277C	MF241222		BOLT,VALVE GEAR TRAIN WASHER ASSEMBLED,6X10	12	12	12	12			9006-1			
03279	MH035135		O-RING,VALVE GEAR TRAIN 17	6	6	6	6			9006-1			
03299	F230510000		NUT,VALVE GEAR TRAIN 10	12	12	12	12			9006-1			
03300	3090400801		SHAFT,ROCKER ARM	6	6					9006-1	9605-3		

11 -230 CAMSHAFT & VALVE

カムシャフト & バルブ

04 6D240 CTJS04US1
 03 6D240 CTJS04000
 02 6D221 CTJS12131 COLD
 01 6D221 CTJS12000 STD

-41-

見出番号 REF.-NO.	部品番号 PART NO.	代 替 R / P 記 号 S C E N O G	部品名称および記事・仕様記号 PART NAME & DESCRIPTION	型式・個数 MODEL & QTY						適用号機 APPLICABLE SERIAL NO.		新 規 V R D	
				0	1	2	3	4		FROM@	@UPTO		
03302B	3090410702		BRACKET,ROCKER SHAFT	6	6						9006-1	9605-3	
	ME150511		BRACKET,ROCKER SHAFT	6	6						9606-1		
	ME150511		BRACKET,ROCKER SHAFT			6	6				9901-1		
03314	3090401600		PLATE,ROCKER SHAFT THRUST	12	12	12	12				9006-1		
03316	ME051180		PUSH ROD,ROCKER ARM	12	12	12	12				9006-1		
03323	ME051051		ROCKER ARM,INLET & EXHAUST VALVE	12	12	12	12				9006-1		
03405	ME051410	R	RETAINER,VALVE SPRING	12	12						9006-1	9810-3	
	(ME095645)												
	ME095645		RETAINER,VALVE SPRING	12	12						9811-1		
	ME095645		RETAINER,VALVE SPRING			12	12				9901-1		
03410	ME051696		VALVE,INLET	6	6	6	6				9006-1		
03412	ME051083		SEAT,VALVE SPRING	12	12	12	12				9006-1		
03416	ME061398		SPRING,VALVE,INR	12	12	12	12				9006-1		
03417	ME051208		SPRING,VALVE,OTR	12	12	12	12				9006-1		
03420	ME051697		VALVE,EXHAUST	6	6	6	6				9006-1		
03440	ME091814	3	SEAL,VALVE STEM	12	12						9006-1	9901-3	
	(ME153274)												
	ME153274		SEAL,VALVE STEM	12	12						9902-1		
	ME091814	3	SEAL,VALVE STEM			12	12				9901-1	9901-3	
	(ME153274)												
	ME153274		SEAL,VALVE STEM			12	12				9902-1		
03450	3120434200		LOCK,VALVE SPRING RETAINER	24	24	24	24				9006-1		

タイミンギヤ
11-240 TIMING GEAR

-42-

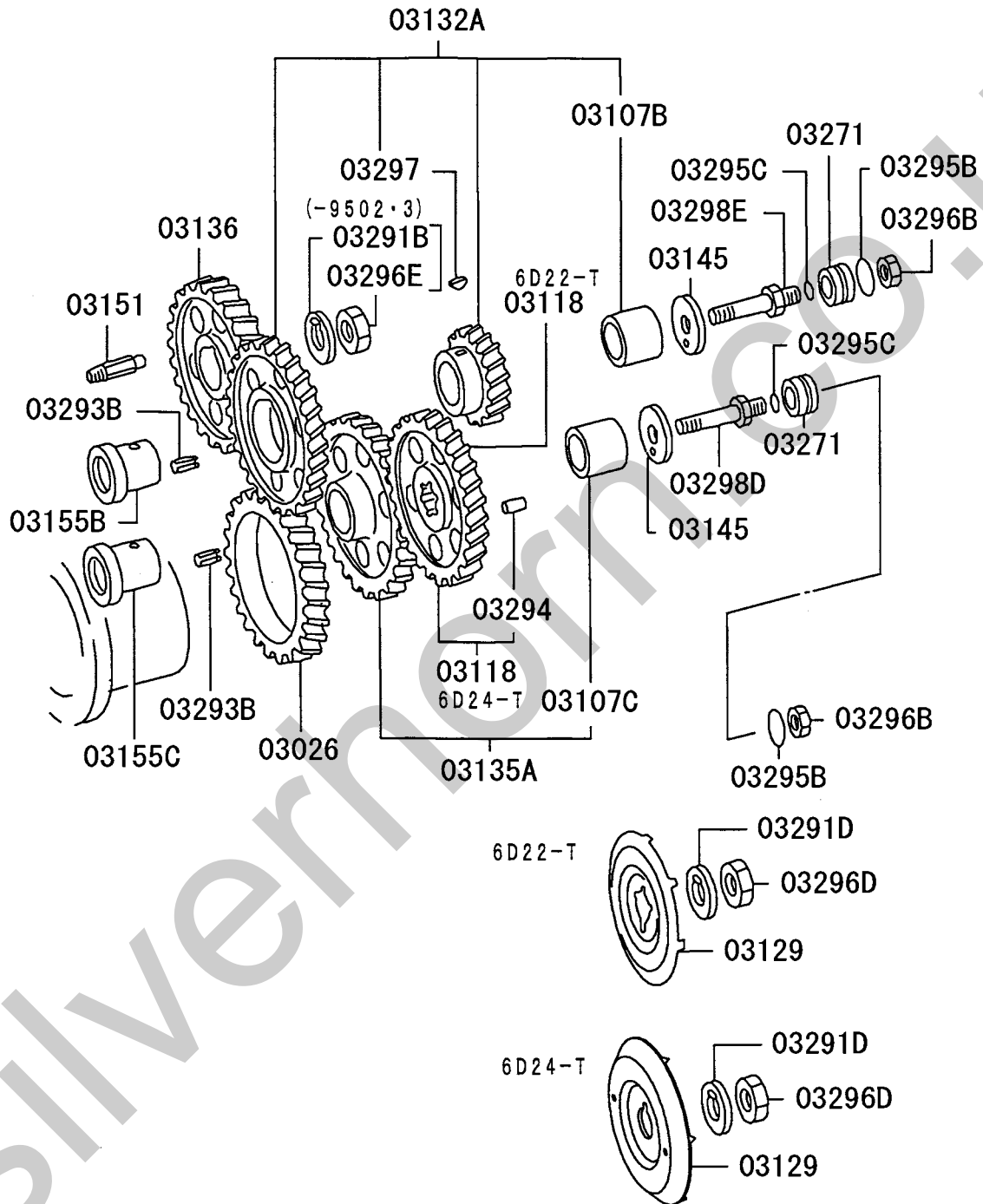

217T01

11 -240 TIMING GEAR

タイミングギヤ

04 6D240 CTJS04US1
 03 6D240 CTJS04000
 02 6D221 CTJS12131 COLD
 01 6D221 CTJS12000 STD

-43-

見出番号 REF.-NO.	部品番号 PART NO.	代 替 順 号 R / S C E N E P O G	部品名称および記事・仕様記号 PART NAME & DESCRIPTION	型式・個数 MODEL & QTY						適用号機 APPLICABLE SERIAL NO.		管 区 M / R	新 規 V R D
				0	1	2	3	4	FROM@	@UPTO			
03026	ME091034		GEAR,CRANKSHAFT N=63	1	1					9006-1			
	ME120129		GEAR,CRANKSHAFT N=63			1	1			9901-1	9912-2		
	ME093097		GEAR,CRANKSHAFT N=63			1	1			9912-3			
03107B	ME062905		BUSHING,TIMING GEAR TRAIN 43X44	1	1	1	1			9006-1			
03107C	ME052843		BUSHING,TIMING GEAR TRAIN 51X50	1	1	1	1			9006-1			
03118	ME052996		GEAR,INJECTION PUMP DRIVE N=63	1	1					9006-1			
	ME052916		GEAR,INJECTION PUMP DRIVE N=63			1	1			9901-1			
03129	ME062660		PLATE,INJECTION PUMP DRIVE GEAR	1	1					9006-1			
	ME158303		PLATE,INJECTION PUMP DRIVE GEAR			1	1			9901-1			
03132A	ME091037	R	GEAR ASSY,CAM IDLER N=33,66	1	1					9006-1	9411-2		
	(ME150506) ME150506		GEAR ASSY,CAM IDLER N=33,66	1	1					9411-3			
	ME150506		GEAR ASSY,CAM IDLER N=33,66			1	1			9901-1			
03135A	ME052940	R	GEAR ASSY,INJECTION PUMP IDLER N=68	1	1					9006-1	9411-2		
	(ME150689) ME150689		GEAR ASSY,INJECTION PUMP IDLER N=68	1	1					9411-3			
	ME150689		GEAR ASSY,INJECTION PUMP IDLER N=68			1	1			9901-1			
03136	ME052942		GEAR,CAMSHAFT N=63	1	1					9006-1	9502-3		
	ME151298		GEAR,CAMSHAFT N=63	1	1					9503-1			
	ME151298		GEAR,CAMSHAFT N=63			1	1			9901-1			
03145	ME062326		PLATE,CAM IDLER GEAR THRUST	2	2	2	2			9006-1			
03151	3090702900		PLUG,TIMING GEAR TRAIN TAPER	1	1	1	1			9006-1			
03155B	ME052769	R	SHAFT,CAM IDLER GEAR	1	1					9006-1	9409-3		
	(ME150519) ME150519		SHAFT,CAM IDLER GEAR	1	1					9410-1			
	ME150519		SHAFT,CAM IDLER GEAR			1	1			9901-1			
03155C	ME052802	R	SHAFT,CAM IDLER GEAR	1	1					9006-1	9409-3		
	(ME150520) ME150520		SHAFT,CAM IDLER GEAR	1	1					9410-1			
	ME150520		SHAFT,CAM IDLER GEAR			1	1			9901-1			
03271	ME062573		COLLAR,TIMING GEAR TRAIN	2	2	2	2			9006-1			
03291B	ME062323		WASHER,TIMING GEAR TRAIN LOCK,27	1	1					9006-1	9502-3		

タイミンギヤ
11 -240 TIMING GEAR

04 6D240 CTJS04US1
03 6D240 CTJS04000
02 6D221 CTJS12131 COLD
01 6D221 CTJS12000 STD

-44-

見出番号 REF.-NO.	部品番号 PART NO.	代 替 R / P	変 更 順 号 S C E N E Q G	部品名称および記事・仕様記号 PART NAME & DESCRIPTION	型式・個数 MODEL & QTY							適用号機 APPLICABLE SERIAL NO.		管 区 M / R	新 規 V R D	
					0	1	2	3	4				FROM@			@UPTO
03291D	3117502109			WASHER,TIMING GEAR TRAIN LOCK,24	1	1	1	1					9006-1			
03293B	MH012037			SPRING PIN,TIMING GEAR TRAIN 5X10	2	2	2	2					9006-1			
03294	MF472402			PIN,TIMING GEAR TRAIN DOWEL,5X12				2	2				9901-1			
03295B	F315603500			O-RING,TIMING GEAR TRAIN 35	2	2	2	2					9006-1			
03295C	3112304100			O-RING,TIMING GEAR TRAIN 15	2	2	2	2					9006-1			
03296B	F230016000			NUT,TIMING GEAR TRAIN 16	2	2							9006-1	9412-3		
	F230516000			NUT,TIMING GEAR TRAIN 16	2	2							9501-1			
	F230516000			NUT,TIMING GEAR TRAIN 16				2	2				9901-1			
03296D	MH004075			NUT,TIMING GEAR TRAIN JAM,24	1	1	1	1					9006-1			
03296E	MH004074			NUT,TIMING GEAR TRAIN JAM,27	1	1							9006-1	9502-3		
03297	F287005019			KEY,TIMING GEAR TRAIN WOODRUFF,5X19	1	1	1	1					9006-1			
03298D	ME052803	R		BOLT,TIMING GEAR TRAIN 16X88	1	1							9006-1	9412-3		
	(ME150508) ME150508			BOLT,TIMING GEAR TRAIN 16X88	1	1							9501-1			
	ME150508			BOLT,TIMING GEAR TRAIN 16X88				1	1				9901-1			
03298E	ME052962	R		BOLT,TIMING GEAR TRAIN 16X78	1	1							9006-1	9412-3		
	(ME150509) ME150509 ME150509			BOLT,TIMING GEAR TRAIN BOLT,TIMING GEAR TRAIN	1	1							9501-1 9901-1			

エアコンプレッサ
11-340 AIR COMPRESSOR

-46-

AIR COMPRESSOR (FOR 1CYL)

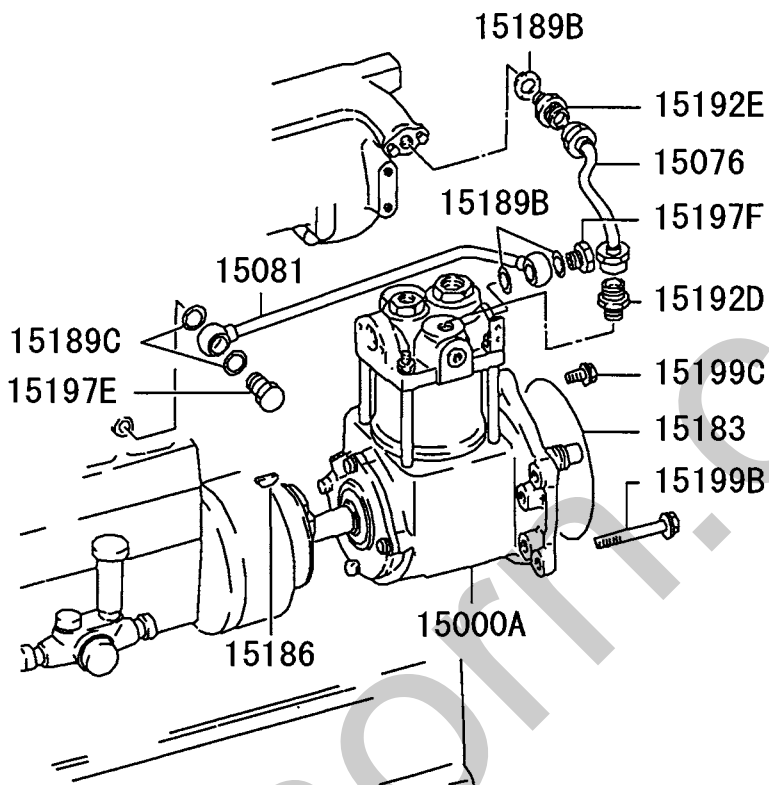

217T01

AIR OUTLET PIPE (FOR 1CYL)

6D22-T (0008・1-)
6D24-T

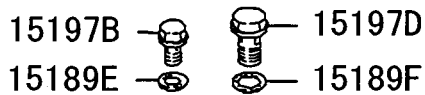

AIR SUCTION PIPE (FOR 1CYL)

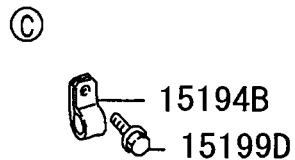
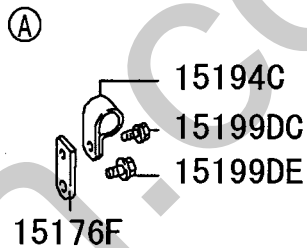
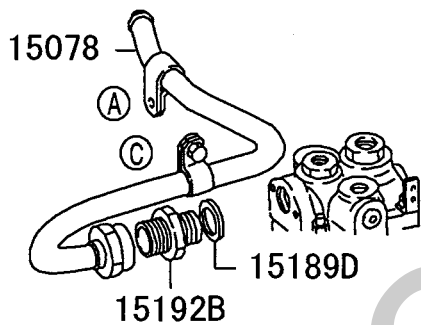

INNER PARTS

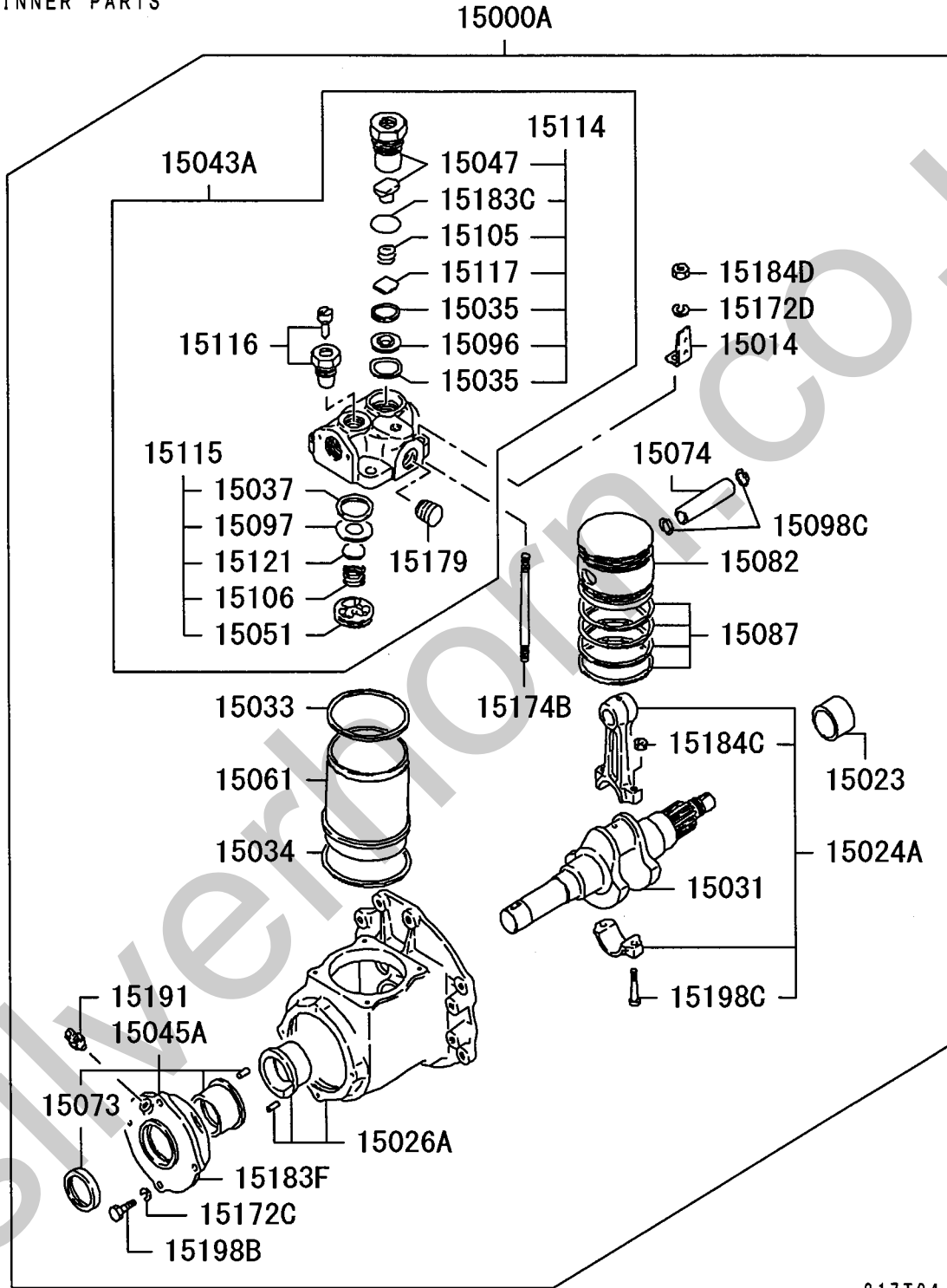

INNER PARTS
(-9906・3)

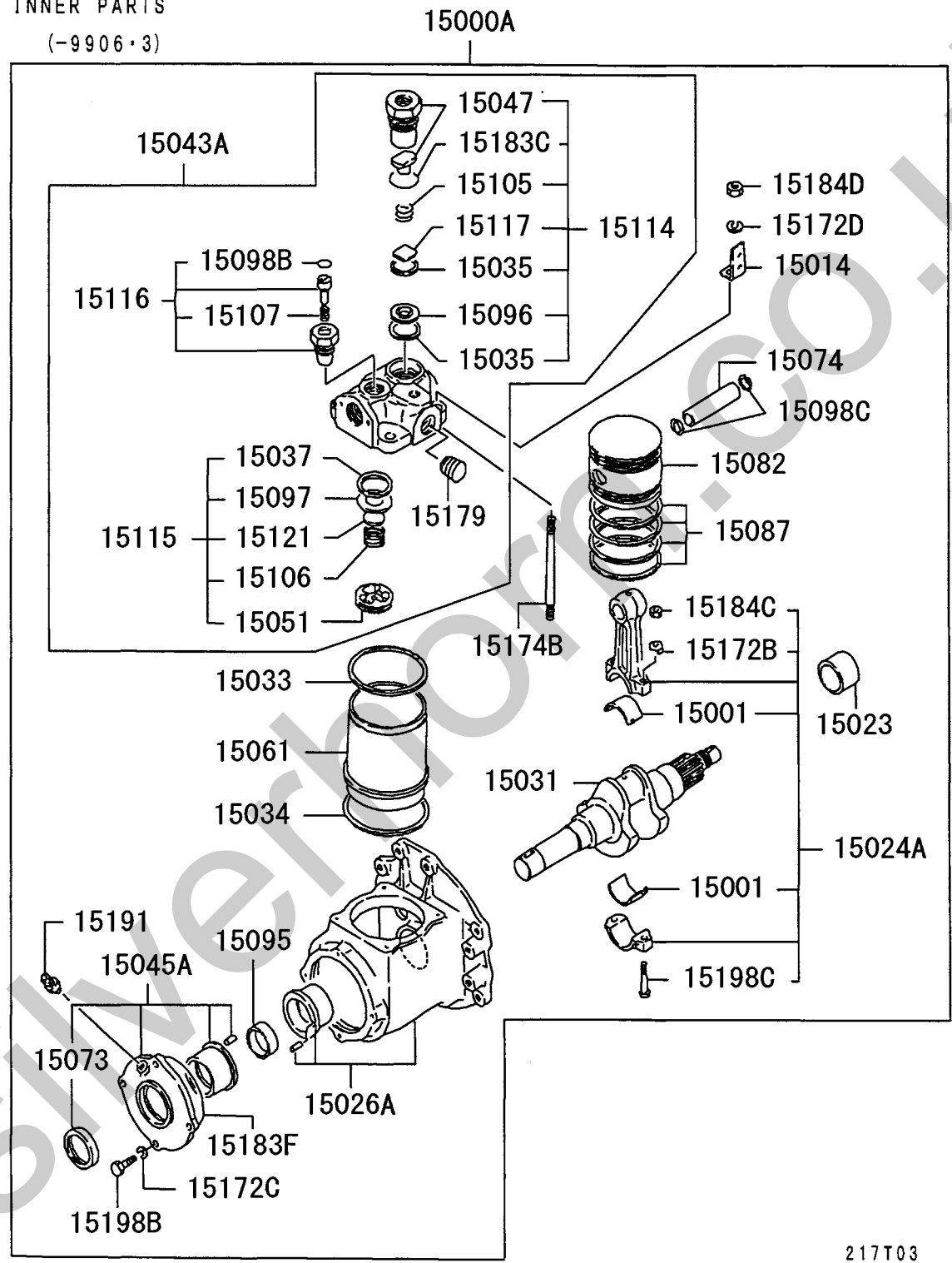

217T03

11 -340 AIR COMPRESSOR

04 6D240 CTJS04US1
 03 6D240 CTJS04000
 02 6D221 CTJS12131 COLD
 01 6D221 CTJS12000 STD

-50-

見出番号 REF.-NO.	部品番号 PART NO.	代 替 R / P	変 記 順 号 S C E N O G	部品名称および記事・仕様記号 PART NAME & DESCRIPTION	型式・個数 MODEL & QTY						適用号機 APPLICABLE SERIAL NO.		管 区 M / R	新 規 V R D
					0	1	2	3	4	FROM@	@UPTO			
15000A	ME150173 (ME150342)	3	R	AIR COMPRESSOR ASSY	1	1					9006-1	9111-3		
	ME150342 (ME150344)			AIR COMPRESSOR ASSY	1	1					9112-1	9703-3		
	ME150344			AIR COMPRESSOR ASSY	1	1					9704-1			
15001	ME150600	3		AIR COMPRESSOR ASSY			1	1			9901-1			
	3097520900 (ME713006)			BEARING,AIR COMPRESSOR CONNROD	2	2					9006-1	9906-3		
15014	ME713006			BEARING,AIR COMPRESSOR CONNROD				2	2		9901-1	9906-3		
15014	ME713031			BRACKET,AIR COMPRESSOR HEAD PIPE	1	1	1	1			9006-1			
15023	3097524600 ME713226			COLLAR,AIR COMPRESSOR COLLAR,AIR COMPRESSOR	1	1					9006-1			
15024A	3097501040 ME737132			CONNECTING ROD ASSY,AIR COMPRESSOR	1	1					9006-1	9906-3		
	3097501040			CONNECTING ROD ASSY,AIR COMPRESSOR	1	1					9907-1			
15026A	ME737132	3		CONNECTING ROD ASSY,AIR COMPRESSOR			1	1			9901-1	9906-3		
	ME057119			CRANKCASE ASSY,AIR COMPRESSOR	1	1	1	1			9006-1			
15031	ME713281 (ME737139)	3		CRANKSHAFT,AIR COMPRESSOR	1	1					9006-1	9111-3		
	ME737137			CRANKSHAFT,AIR COMPRESSOR	1	1					9112-1			V
	ME737041 (ME737139)	3		CRANKSHAFT,AIR COMPRESSOR			1	1			9901-1	9906-3		
	ME737139			CRANKSHAFT,AIR COMPRESSOR				1	1		9907-1			
15033	3097524500			GASKET,AIR COMPRESSOR CYLINDER HEAD	1	1	1	1			9006-1			
15034	3097521900 (ME713329)	3		GASKET,AIR COMPRESSOR CYLINDER LINER	1	1					9006-1	9703-3		
	ME713329			GASKET,AIR COMPRESSOR CYLINDER LINER	1	1					9704-1			
15035	3097522800			GASKET,AIR COMPRESSOR DELIVERY VALVE	2	2	2	2			9901-1			
15037	3097523500 (ME713020)	R		GASKET,AIR COMPRESSOR SUCTION VALVE	1	1					9006-1			
	ME713020			GASKET,AIR COMPRESSOR SUCTION VALVE				1	1			9901-1		
15043A	ME713206			HEAD ASSY,AIR COMPRESSOR CYLINDER	1	1	1	1			9006-1			
15045A	ME713230			HOLDER ASSY,AIR COMPRESSOR BEARING	1	1					9006-1	9111-3		
	ME713424			HOLDER ASSY,AIR COMPRESSOR BEARING	1	1					9112-1	9906-3		
	ME737215			HOLDER ASSY,AIR COMPRESSOR BEARING	1	1					9907-1			
	ME737042			HOLDER ASSY,AIR COMPRESSOR BEARING			1	1			9901-1	9906-3		
	ME737214			HOLDER ASSY,AIR COMPRESSOR BEARING			1	1			9907-1			
15047	ME713224			HOLDER,AIR COMPRESSOR DELIVERY VALVE	1	1	1	1			9006-1			
15051	3097523100			HOLDER,AIR COMPRESSOR SUCTION VALVE	1	1	1	1			9006-1			
15061	3097522100			LINER,AIR COMPRESSOR CYLINDER	1	1	1	1			9006-1			
15073	3097520600	3		OIL SEAL,AIR COMPRESSOR CRANKSHAFT,FR	1	1					9006-1	9111-3		
	ME713419 (ME737121)			OIL SEAL,AIR COMPRESSOR CRANKSHAFT,FR	1	1					9112-1			
	ME737118			OIL SEAL,AIR COMPRESSOR CRANKSHAFT,FR			1	1			9901-1	9906-3		
	ME737204			OIL SEAL,AIR COMPRESSOR CRANKSHAFT,FR			1	1			9907-1			
15074	3097521700 (ME737202)	3		PIN,AIR COMPRESSOR PISTON	1	1					9006-1	9906-3		
	ME737202			PIN,AIR COMPRESSOR PISTON	1	1					9907-1			
	ME713011	3		PIN,AIR COMPRESSOR PISTON			1	1			9901-1	9906-3		

11 -340 AIR COMPRESSOR

04 6D240 CTJS04US1
 03 6D240 CTJS04000
 02 6D221 CTJS12131 COLD
 01 6D221 CTJS12000 STD

-51-

見出番号 REF.-NO.	部品番号 PART NO.	代 替 R / P	変 更 順 号 S C E N E Q G	部品名称および記事・仕様記号 PART NAME & DESCRIPTION	型式・個数 MODEL & QTY					適用号機 APPLICABLE SERIAL NO.		管 区 M / R	新 規 V R D
					0	1	2	3	4	FROM@	@UPTO		
15076	(ME737202) ME737202			PIN,AIR COMPRESSOR PISTON			1	1			9907-1		
15078	ME150237			PIPE,AIR COMPRESSOR WATER OUTLET	1	1	1	1			9006-1		
15081	ME157205			PIPE,AIR COMPRESSOR SUCTION	1	1	1	1			9006-1		
15082	ME150236			PIPE,AIR COMPRESSOR WATER INLET	1	1	1	1			9006-1		
	ME713114	3		PISTON,AIR COMPRESSOR CYLINDER	1	1					9006-1	9906-3	
	(ME713361) ME713361			PISTON,AIR COMPRESSOR CYLINDER	1	1					9907-1		
	ME713114	3		PISTON,AIR COMPRESSOR CYLINDER				1	1		9901-1	9906-3	
	(ME713361) ME713361			PISTON,AIR COMPRESSOR CYLINDER				1	1		9907-1		
15087	ME713327	#		RING SET,AIR COMPRESSOR PISTON T03016	1	1	1	1			9006-1		
15095	ME713420			SLEEVE,AIR COMPRESSOR CRANKSHAFT	1	1					9112-1	9803-1	
	ME737125			SLEEVE,AIR COMPRESSOR CRANKSHAFT	1	1					9803-2	9906-3	
15096	ME737123			SLEEVE,AIR COMPRESSOR CRANKSHAFT			1	1			9901-1	9906-3	
15097	3097522700			SEAT,AIR COMPRESSOR DELIVERY VALVE	1	1	1	1			9006-1		
	3097523400	3		SEAT,AIR COMPRESSOR SUCTION VALVE	1	1					9006-1		
	(ME713019) ME713019			SEAT,AIR COMPRESSOR SUCTION VALVE				1	1		9901-1		
15098B	3097524300	3		SNAP RING,AIR COMPRESSOR INR	1	1					9006-1	9906-3	
	(3097516200) ME713080			SNAP RING,AIR COMPRESSOR INR				1	1		9901-1	9906-3	
15098C	3097521800	R		SNAP RING,AIR COMPRESSOR INR	2	2					9006-1		
	(ME713078) ME713078			SNAP RING,AIR COMPRESSOR INR				2	2		9901-1		
15105	3097522500	R		SPRING,AIR COMPRESSOR DELIVERY VALVE	1	1	1	1			9006-1		
15106	(ME713021) 3097523200	R		SPRING,AIR COMPRESSOR SUCTION VALVE	1	1	1	1			9006-1		
	(ME713017) 3097524200			SPRING,AIR COMPRESSOR UNLOADER VALVE	1	1	1	1			9006-1	9906-3	
15114	3097502060			VALVE KIT,AIR COMPRESSOR DELIVERY	1	1	1	1			9006-1		
15115	3097502070			VALVE KIT,AIR COMPRESSOR SUCTION	1	1	1	1			9006-1		
15116	3097501070	3		VALVE KIT,AIR COMPRESSOR UNLOADER	1	1					9006-1	9906-3	
	(ME737130) ME737130			VALVE KIT,AIR COMPRESSOR UNLOADER	1	1					9907-1		
	3097501070	3		VALVE KIT,AIR COMPRESSOR UNLOADER				1	1		9901-1	9906-3	
	(ME737130) ME737130			VALVE KIT,AIR COMPRESSOR UNLOADER				1	1		9907-1		
15117	3097522600	R		VALVE,AIR COMPRESSOR DELIVERY	1	1					9006-1		
	(ME713022) ME713022			VALVE,AIR COMPRESSOR DELIVERY				1	1		9901-1		
15121	3097523300			VALVE,AIR COMPRESSOR SUCTION	1	1	1	1			9006-1		
15172B	3097521200	R		WASHER,AIR COMPRESSOR INR	2	2					9006-1	9906-3	
	(ME713009) ME713009			WASHER,AIR COMPRESSOR INR				2	2		9901-1	9906-3	
15172C	0334013024			WASHER,AIR COMPRESSOR INR SPRING,8	4	4					9006-1		
	ME713076			WASHER,AIR COMPRESSOR INR				4	4		9901-1		
15172D	F251510000			WASHER,AIR COMPRESSOR INR	4	4	4	4			9006-1		

11 -340 AIR COMPRESSOR

04 6D240 CTJS04US1
 03 6D240 CTJS04000
 02 6D221 CTJS12131 COLD
 01 6D221 CTJS12000 STD

-52-

見出番号 REF.-NO.	部品番号 PART NO.	代 替 R / P	変 更 順 号 S C E N / O G	部品名称および記事・仕様記号 PART NAME & DESCRIPTION	型式・個数 MODEL & QTY					適用号機 APPLICABLE SERIAL NO. FROM@- :@UPTO	管 区 M / R	新 規 V / R / D
					0	1	2	3	4			
				SPRING,10								
15174B	ME713208			STUD,AIR COMPRESSOR	4	4	4	4		9006-1		
15176F	3097504400			STAY,AIR COMPRESSOR	1	1	1	1		9006-1		
15179	ME713385			PLUG,AIR COMPRESSOR INR	1	1	1	1		9006-1		
15183	MH035606			O-RING,AIR COMPRESSOR	1	1				9006-1	0107-3	
	ME093522			154 O-RING,AIR COMPRESSOR	1	1				0108-1		
	MH035606			153.4 O-RING,AIR COMPRESSOR				1	1	9901-1	0107-3	
	ME093522			154 O-RING,AIR COMPRESSOR				1	1	0108-1		
15183C	3097522900			153.4 O-RING,AIR COMPRESSOR	1	1	1	1		9006-1		
15183F	ME713337			O-RING,AIR COMPRESSOR	1	1	1	1		9006-1		
15184C	3097525100			NUT,AIR COMPRESSOR INR	2	2				9006-1	9906-3	
	ME737201			NUT,AIR COMPRESSOR INR	2	2				9907-1		
	ME713008			NUT,AIR COMPRESSOR INR			2	2		9901-1	9906-3	
	ME737201			NUT,AIR COMPRESSOR INR			2	2		9907-1		
15184D	0634831018 (ME713082)	R		NUT,AIR COMPRESSOR INR	4	4				9006-1		
	ME713082			NUT,AIR COMPRESSOR INR			4	4		9901-1		
15186	F287005022			10 KEY,AIR COMPRESSOR	1	1				9006-1		
	MF476220			WOODRUFF,5X22 KEY,AIR COMPRESSOR				1	1	9901-1		
				WOODRUFF,6X25								
15189B	F420214000			GASKET,AIR COMPRESSOR	3	3	3	3		9006-1		
				14								
15189C	F420216000			GASKET,AIR COMPRESSOR	2	2	2	2		9006-1		
				16								
15189D	F420227000			GASKET,AIR COMPRESSOR	1	1	1	1		9006-1		
				27								
15189E	MH035160	R		GASKET,AIR COMPRESSOR	2	2				9006-1	9412-3	
	(MH035190)			18								
	MH035190			GASKET,AIR COMPRESSOR	2	2				9501-1		
				18				2	2	9901-1		
15189F	MH035161	R		GASKET,AIR COMPRESSOR	2	2				9006-1	9412-3	
	(MH035192)			24								
	MH035192			GASKET,AIR COMPRESSOR	2	2				9501-1		
				24				2	2	9901-1		
	MH035192			GASKET,AIR COMPRESSOR								
				24								
15191	ME713196			JOINT,AIR COMPRESSOR INR	1	1	1	1		9006-1		
15192B	MH038913			JOINT,AIR COMPRESSOR	1	1	1	1		9006-1		
15192D	MH037507			JOINT,AIR COMPRESSOR	1	1	1	1		9006-1		
15192E	MH037453			JOINT,AIR COMPRESSOR	1	1	1	1		9006-1		

11 -340 AIR COMPRESSOR

エフコンプレッサ

04 6D240 CTJS04US1
 03 6D240 CTJS04000
 02 6D221 CTJS12131 COLD
 01 6D221 CTJS12000 STD

-53-

見出番号 REF.-NO.	部品番号 PART NO.	代 替 順 号 R / S C E N E P O G	部品名称および記事・仕様記号 PART NAME & DESCRIPTION	型式・個数 MODEL & QTY						適用号機	管 区 M / R	新 規 V R D
				0	1	2	3	4		APPLICABLE SERIAL NO.		
				FROM@-	@UPTO							
15194B	MH020290		CLIP,AIR COMPRESSOR 20	1	1	1	1			9006-1		
15194C	MH020558		CLIP,AIR COMPRESSOR D=20	1	1	1	1			9006-1		
15197B	MF650106		EYEBOLT,AIR COMPRESSOR 18X28	1	1	1	1			9006-1		
15197D	3097506600		EYEBOLT,AIR COMPRESSOR 24X36	1	1	1	1			9006-1		
15197E	F461016000		EYEBOLT,AIR COMPRESSOR 16X29	1	1	1	1			9006-1		
15197F	MH037087		EYEBOLT,AIR COMPRESSOR 14X26	1	1	1	1			9006-1		
15198B	F102508022		BOLT,AIR COMPRESSOR INR 8X22	4	4					9006-1		
	ME713077		BOLT,AIR COMPRESSOR INR 8X22			4	4			9901-1		
15198C	ME713093		BOLT,AIR COMPRESSOR INR	2	2	2	2			9006-1		
15199B	MH000724		BOLT,AIR COMPRESSOR FLANGE,10X85	5	5					9006-1	0202-3	
	MS146023		BOLT,AIR COMPRESSOR FLANGE,10X85	5	5					0203-1		
	MH000724		BOLT,AIR COMPRESSOR FLANGE,10X85			5	5			9901-1	0202-3	
	MS146023		BOLT,AIR COMPRESSOR FLANGE,10X85			5	5			0203-1		
15199C	MH000713	#	BOLT,AIR COMPRESSOR FLANGE,10X20 T02406A	1	1					9006-1	0211-1	
	MS146003		BOLT,AIR COMPRESSOR FLANGE,10X18	1	1					0211-2		
	MH000713	#	BOLT,AIR COMPRESSOR FLANGE,10X20 T02406A			1	1			9901-1	0211-1	
	MS146003		BOLT,AIR COMPRESSOR FLANGE,10X18			1	1			0211-2		
15199D	MH000706		BOLT,AIR COMPRESSOR FLANGE,10X16	1	1					9006-1	0211-1	
	MS146003		BOLT,AIR COMPRESSOR FLANGE,10X18	1	1					0211-2		
	MH000706		BOLT,AIR COMPRESSOR FLANGE,10X16			1	1			9901-1	0211-1	
	MS146003		BOLT,AIR COMPRESSOR FLANGE,10X18			1	1			0211-2		
15199DC	MH000999		BOLT,AIR COMPRESSOR FLANGE,6X12	1	1	1	1			9006-1		
15199DE	MH000922		BOLT,AIR COMPRESSOR FLANGE,12X16	1	1	1	1			9006-1		

11 -410 ATTACHING PARTS

アタッチング パーツ

-54-

SIDE COVER

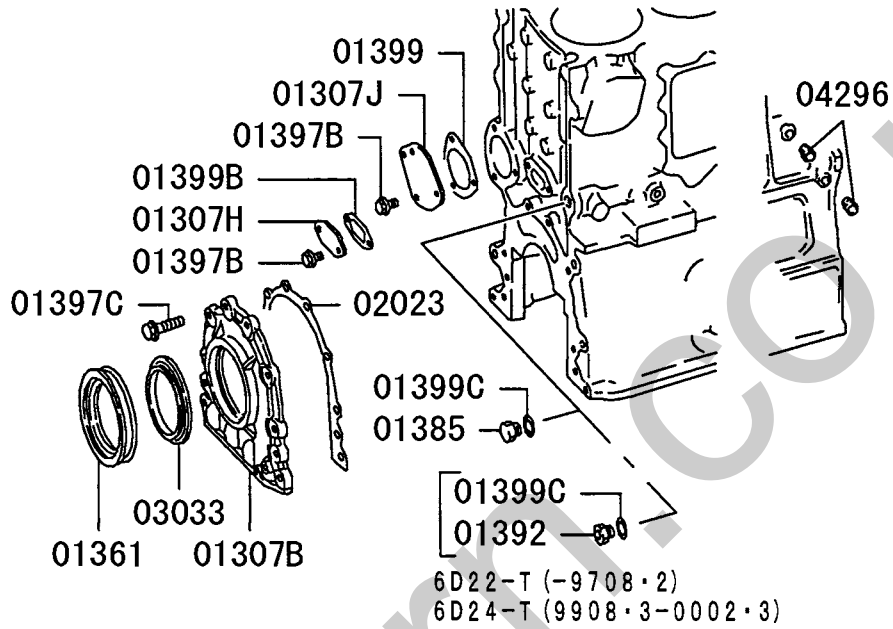

RH

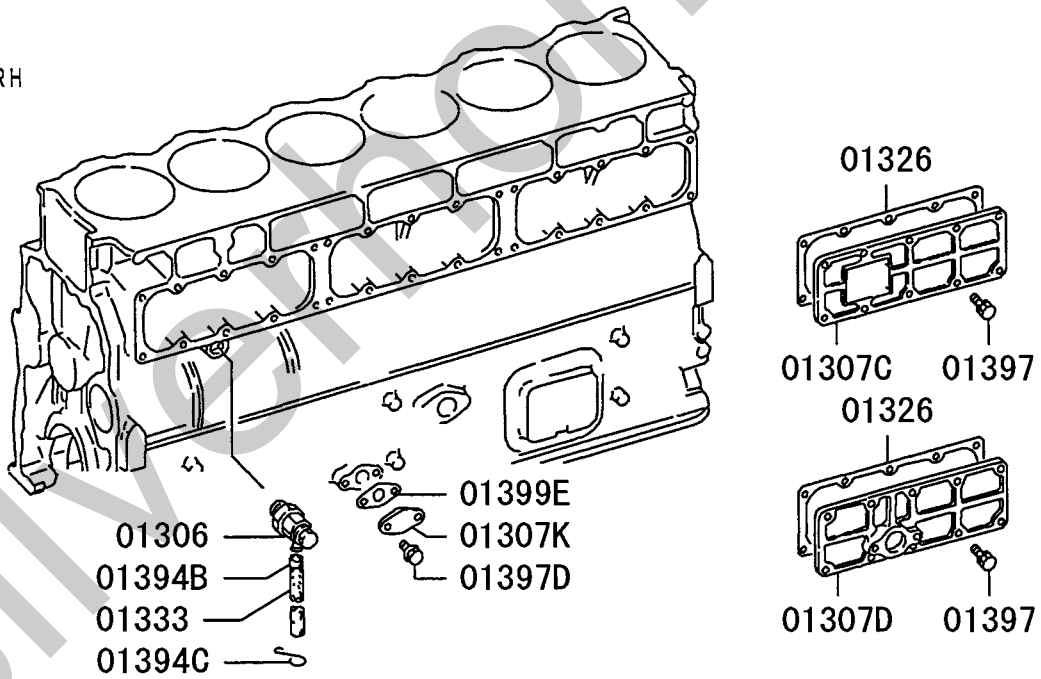

217T01

ENGINE HANGER

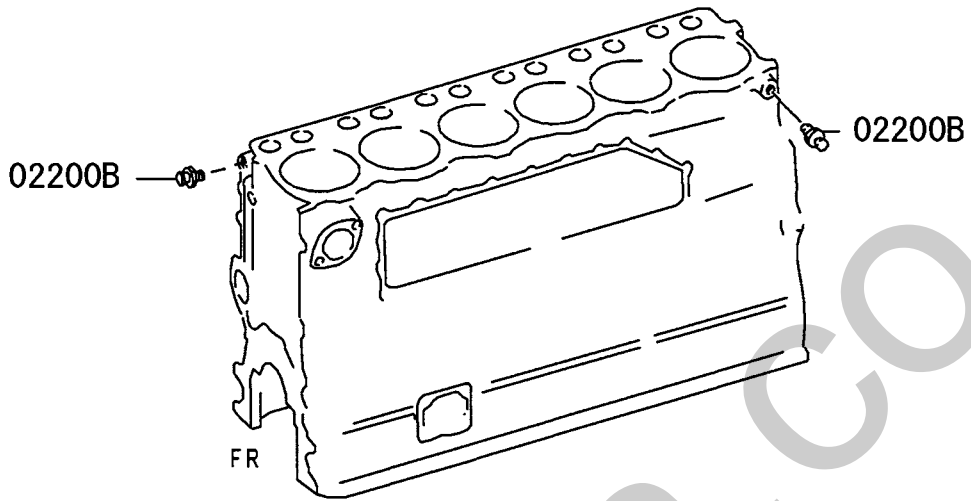

6D22-T (-9708・2)

6D24-T (9908・3-0002・3)

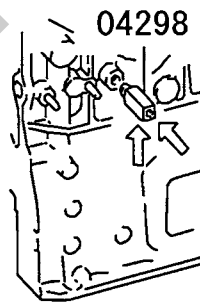

04296



11 -410 ATTACHING PARTS

アタッチング パーツ

04 6D240 CTJS04US1
 03 6D240 CTJS04000
 02 6D221 CTJS12131 COLD
 01 6D221 CTJS12000 STD

-56-

見出番号 REF.-NO.	部品番号 PART NO.	代 替 R / P	変 更 順 号 S C E N / Q G	部品名称および記事・仕様記号 PART NAME & DESCRIPTION	型式・個数 MODEL & QTY						適用号機 APPLICABLE SERIAL NO.		管 区 M / R	新 規 V / R / D		
					0	1	0	2	0	3	0	4			FROM@	@UPTO
01306	3170705201	3		COCK,CYLINDER BLOCK WATER DRAIN	1	1							9006-1	9908-3		
	ME133039 (ME131935)			COCK,CYLINDER BLOCK WATER DRAIN	1	1								9909-1		
	3170705201	3		COCK,CYLINDER BLOCK WATER DRAIN			1	1					9901-1	9908-3		
	ME133039 (ME131935)			COCK,CYLINDER BLOCK WATER DRAIN			1	1					9909-1			
01307B	ME120432	#		COVER,CYLINDER BLOCK	1	1	1	1					9006-1			
01307C	ME051003			COVER,CYLINDER BLOCK T03092	1	1	1	1						9006-1		
01307D	ME051344			COVER,CYLINDER BLOCK	2	2	2	2					9006-1			
01307H	3090702600			COVER,CYLINDER BLOCK	1	1	1	1						9006-1		
01307J	3090703500			COVER,CYLINDER BLOCK	1	1	1	1					9006-1			
01307K	ME051241			COVER,CYLINDER BLOCK	1	1	1	1						9006-1		
01326	ME051635 (ME150858)	3		GASKET,CYLINDER BLOCK SIDE COVER	3	3							9006-1	9412-3		
	ME150858 (ME152473)	R		GASKET,CYLINDER BLOCK SIDE COVER	3	3							9501-1	9611-3		
	ME152473			GASKET,CYLINDER BLOCK SIDE COVER	3	3							9612-1			
	ME152473			GASKET,CYLINDER BLOCK SIDE COVER			3	3						9901-1		
01333	3090705800			HOSE,CYLINDER BLOCK WATER DRAIN 12X380	1	1	1	1					9006-1			
	ME060124					OIL SEAL,CYLINDER BLOCK FR COVER	1	1	1	1						
01361	MH037723			PLUG,CYLINDER BLOCK	1	1							9708-3			
01385	MH037723			PLUG,CYLINDER BLOCK SCREW,27					1	1						
	MH037723			PLUG,CYLINDER BLOCK SCREW,27					1	1			0003-1			
01392	MH038358					JOINT,CYLINDER BLOCK	1	1	1	1						
01394B	0945601600			CLAMP,CYLINDER BLOCK D=16	1	1							9006-1	9908-3		
	ME153301					CLAMP,CYLINDER BLOCK D=20.5	1	1								
	0945601600			CLAMP,CYLINDER BLOCK D=16					1	1			9901-1	9908-3		
	ME153301					CLAMP,CYLINDER BLOCK D=20.5					1	1				
01394C	3000715301			CLAMP,CYLINDER BLOCK D=18,11	1	1	1	1					9006-1			
01397	MF300845					BOLT,CYLINDER BLOCK	2	2								
	MF303365			WASHER ASSEMBLED,10X30									9006-1			
	MF300845					BOLT,CYLINDER BLOCK WASHER ASSEMBLED,10X30	28	28								
	MF300845			BOLT,CYLINDER BLOCK WASHER ASSEMBLED,10X30			2	2					9901-1			
	MF303365					BOLT,CYLINDER BLOCK WASHER ASSEMBLED,10X30			28	28						
01397B	MH000713	#		BOLT,CYLINDER BLOCK FLANGE,10X20 T02406A	5	5							9006-1	0306-2		
	MS146004			BOLT,CYLINDER BLOCK	5	5							0306-3			

11 -410 ATTACHING PARTS

アタッチング パーツ

04 6D240 CTJS04US1
 03 6D240 CTJS04000
 02 6D221 CTJS12131 COLD
 01 6D221 CTJS12000 STD

-57-

見出番号 REF.-NO.	部品番号 PART NO.	代 替 R / P 記 順 号 S C E N E Q G	部品名称および記事・仕様記号 PART NAME & DESCRIPTION	型式・個数 MODEL & QTY					適用号機 APPLICABLE SERIAL NO.		管 区 M / R D	新 規 V / R D	
				0	1	2	3	4	FROM@	@UPTO			
	MH000713	#	FLANGE,10X20										
	MS146004		BOLT,CYLINDER BLOCK FLANGE,10X20 T02406A			5	5			9901-1	0306-2		
			BOLT,CYLINDER BLOCK FLANGE,10X20			5	5			0306-3			
01397C	MH000727		BOLT,CYLINDER BLOCK FLANGE,12X30	8	8					9006-1	9910-2		
	MS146053		BOLT,CYLINDER BLOCK FLANGE,12X30	8	8					9910-3			
	MH000727		BOLT,CYLINDER BLOCK FLANGE,12X30			8	8			9901-1	9910-2		
	MS146053		BOLT,CYLINDER BLOCK FLANGE,12X30			8	8			9910-3			
01397D	MH000706		BOLT,CYLINDER BLOCK FLANGE,10X16	2	2					9006-1	9910-2		
	MS146004		BOLT,CYLINDER BLOCK FLANGE,10X20	2	2					9910-3			
	MH000706		BOLT,CYLINDER BLOCK FLANGE,10X16			2	2			9901-1	9910-2		
	MS146004		BOLT,CYLINDER BLOCK FLANGE,10X20			2	2			9910-3			
01399	3090702501 (ME150056)	R	GASKET,CYLINDER BLOCK	1	1					9006-1	9412-3		
	ME150056		GASKET,CYLINDER BLOCK	1	1					9501-1			
	ME150056		GASKET,CYLINDER BLOCK			1	1			9901-1			
01399B	3090702701 (ME150057)	R	GASKET,CYLINDER BLOCK	1	1					9006-1	9412-3		
	ME150057		GASKET,CYLINDER BLOCK	1	1					9501-1			
	ME150057		GASKET,CYLINDER BLOCK			1	1			9901-1			
01399C	F420227000		GASKET,CYLINDER BLOCK	1	1	1	1			9006-1			
			27										
01399E	ME054744		GASKET,CYLINDER BLOCK	1	1	1	1			9006-1			
02023	ME120433 (ME150058)	R	GASKET,CRANKSHAFT FR OIL SEAL CASE	1	1					9006-1	9412-3		
	ME150058		GASKET,CRANKSHAFT FR OIL SEAL CASE	1	1					9501-1			
	ME150058		GASKET,CRANKSHAFT FR OIL SEAL CASE			1	1			9901-1			
02200B	ME040252		ENGINE HANGER	2	2	2	2			9006-1			
03033	ME060125		OIL SLINGER,CRANKSHAFT,FR	1	1	1	1			9006-1			
04296	MS666220		PLUG,ENG OIL PRESSURE GAUGE TAPER,1/8	3	3					9006-1	9708-2		
	MS666220		PLUG,ENG OIL PRESSURE GAUGE TAPER,1/8	4	4					9708-3	0112-3		
	MH037788		PLUG,ENG OIL PRESSURE GAUGE TAPER,1/8	2	2					0201-1			
	MS666220		PLUG,ENG OIL PRESSURE GAUGE TAPER,1/8	2	2					0201-1			
	MS666220		PLUG,ENG OIL PRESSURE GAUGE TAPER,1/8			4	4			9901-1	0112-3		
	MH037788		PLUG,ENG OIL PRESSURE GAUGE TAPER,1/8			2	2			0201-1			

11 -410 11-410 ATTACHING PARTS

アタッチング パーツ

04 6D240 CTJS04US1
 03 6D240 CTJS04000
 02 6D221 CTJS12131 COLD
 01 6D221 CTJS12000 STD

-58-

見出番号 REF.-NO.	部品番号 PART NO.	代 替 R / P	変 更 順 号 S C E N E Q G	部品名称および記事・仕様記号 PART NAME & DESCRIPTION	型式・個数 MODEL & QTY						適用号機 APPLICABLE SERIAL NO. FROM@-@UPTO	管 区 M / R	新 規 V R D
					0	1	2	3	4				
04298	MS666220			PLUG,ENG OIL PRESSURE GAUGE TAPER,1/8			2	2			0201-1		
	MH039033			JOINT,ENG OIL PRESSURE GAUGE	1	1					9006-1	9708-2	
	MH039564			JOINT,ENG OIL PRESSURE GAUGE	1	1					9708-3		
	MH039564			JOINT,ENG OIL PRESSURE GAUGE			1	1			9901-1	9908-2	
	MH039406			JOINT,ENG OIL PRESSURE GAUGE			1	1			9908-3	0002-3	
	MH039564			JOINT,ENG OIL PRESSURE GAUGE			1	1			0003-1		

オイルポンプ & ストレーナ
12-110 OIL PUMP & STRAINER

-60-

OIL PUMP
6D22-T

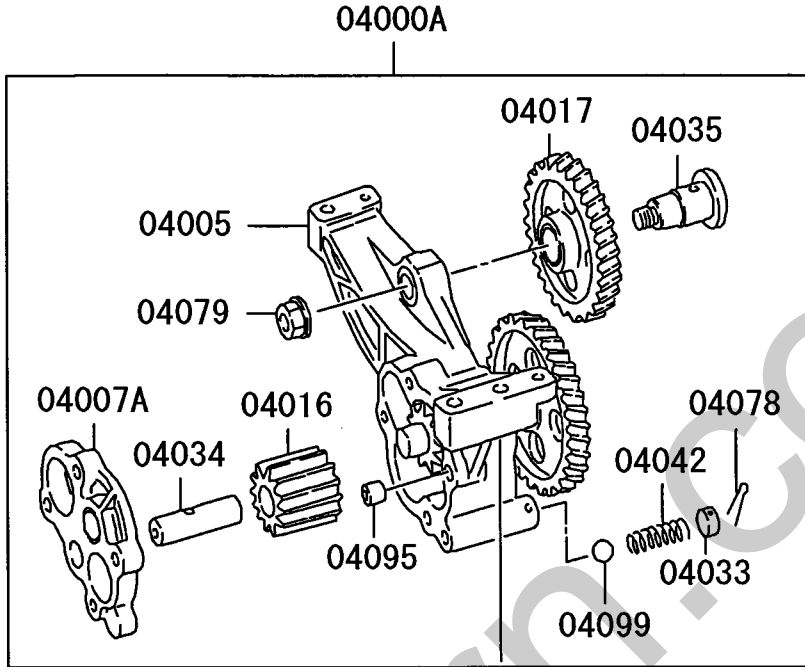

6D24-T

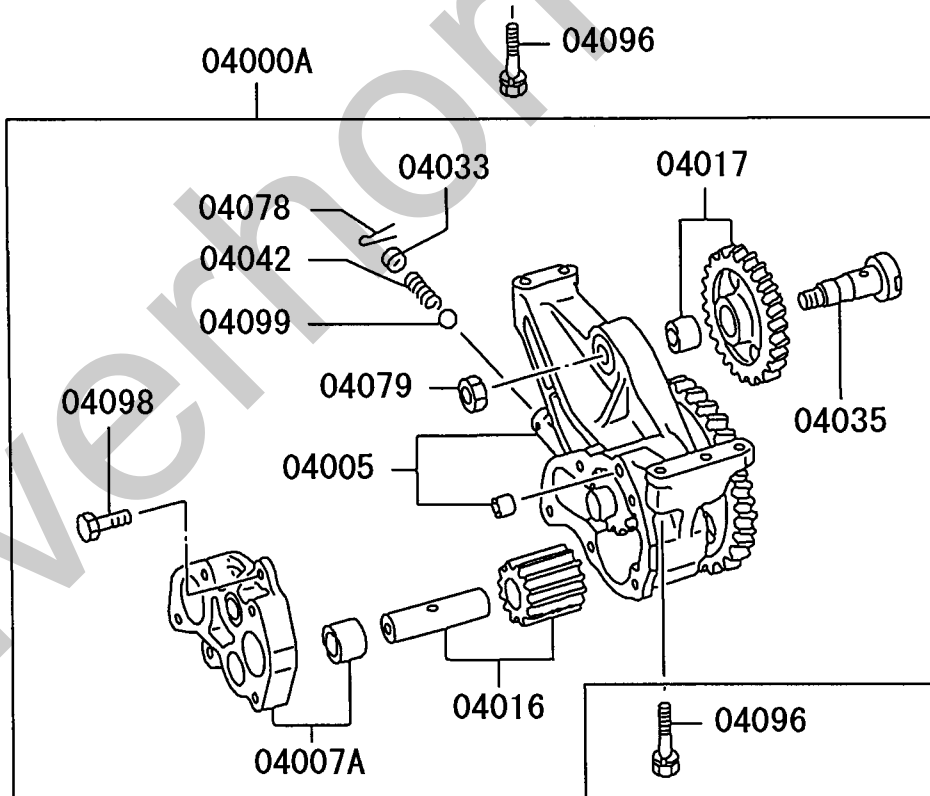

217T01

OIL STRAINER

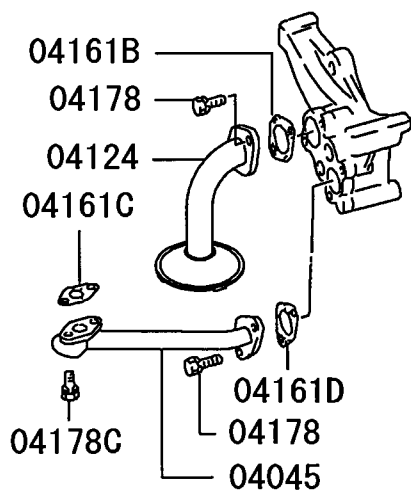

オイルポンプ & ストレーナ
12-110 OIL PUMP & STRAINER

04 6D240 CTJS04US1
03 6D240 CTJS04000
02 6D221 CTJS12131 COLD
01 6D221 CTJS12000 STD

-62-

見出番号 REF.-NO.	部品番号 PART NO.	代 替 R / P	変 更 順 号 S C E N E Q G	部品名称および記事・仕様記号 PART NAME & DESCRIPTION	型式・個数 MODEL & QTY					適用号機 APPLICABLE SERIAL NO.		管 区 M / R	新 規 V R D
					0	1	2	3	4	FROM@	@UPTO		
04000A	ME120351			OIL PUMP ASSY,ENG	1	1					9006-1		
	ME150601			OIL PUMP ASSY,ENG			1	1			9901-1		
04005	ME120385			GEAR & CASE KIT,ENG OIL PUMP	1	1					9006-1		
	ME151877			GEAR & CASE KIT,ENG OIL PUMP			1	1			9901-1		
04007A	ME054373			COVER ASSY,ENG OIL PUMP	1	1					9006-1		
	ME150637 (ME350565)	3		COVER ASSY,ENG OIL PUMP			1	1			9901-1	0008-2	
	ME350565			COVER ASSY,ENG OIL PUMP			1	1			0008-3		
04016	3123500044			GEAR,ENG OIL PUMP DRIVEN	1	1					9006-1		
	ME160708			GEAR,ENG OIL PUMP DRIVEN			1	1			9901-1		
04017	ME054703			GEAR,ENG OIL PUMP IDLER	1	1					9006-1		
	ME150639			GEAR,ENG OIL PUMP IDLER			1	1			9901-1		
04033	3093615300			SEAT,ENG OIL PUMP RELIEF VALVE	1	1					9006-1		
	ME160715			SEAT,ENG OIL PUMP RELIEF VALVE			1	1			9901-1		
04034	3123500501			SHAFT,ENG OIL PUMP DRIVEN GEAR	1	1					9006-1		
04035	ME054372			SHAFT,ENG OIL PUMP IDLER GEAR	1	1					9006-1		
	ME162632			SHAFT,ENG OIL PUMP IDLER GEAR			1	1			9901-1		
04042	3093615200			SPRING,ENG OIL PUMP RELIEF VALVE	1	1					9006-1		
	ME160705			SPRING,ENG OIL PUMP RELIEF VALVE			1	1			9901-1		
04045	ME054171			TUBE,ENG OIL PUMP OUTLET	1	1					9006-1		
	ME121284			TUBE,ENG OIL PUMP OUTLET			1	1			9901-1		
04078	MF472086			PIN,ENG OIL PUMP INR SPLIT,4X35	1	1	1	1			9006-1		
04079	MH004069			NUT,ENG OIL PUMP INR FLANGE,12	1	1	1	1			9006-1		
04095	ME034549			BUSHING,ENG OIL PUMP INR	1	1					9006-1		
04096	MF300850			BOLT,ENG OIL PUMP WASHER ASSEMBLED,10X45	3	3	3	3			9006-1		
04098	MH000715			BOLT,ENG OIL PUMP INR FLANGE,10X35			2	2			9901-1		
04099	F800020000			BALL,ENG OIL PUMP INR 5/8	1	1					9006-1		
	MF540021			BALL,ENG OIL PUMP INR			1	1			9901-1		
04124	ME054393			STRAINER,ENG OIL PAN	1	1					9006-1		
	ME150532			STRAINER,ENG OIL PAN			1	1			9901-1		
04161B	3123674200 (ME150063)	R		GASKET,OIL STRAINER	1	1					9006-1	9412-3	
	ME150063			GASKET,OIL STRAINER	1	1					9501-1		
	ME150541			GASKET,OIL STRAINER			1	1			9901-1	0312-3	
	ME351447			GASKET,OIL STRAINER			1	1			0401-1		V
04161C	3093601200 (ME150065)	R		GASKET,OIL STRAINER	1	1					9006-1	9412-3	
	ME151866			GASKET,OIL STRAINER	1	1					9501-1	0304-3	
	ME351483			GASKET,OIL STRAINER	1	1					0305-1		
	ME151866			GASKET,OIL STRAINER			1	1			9901-1	0203-3	
	ME351483			GASKET,OIL STRAINER			1	1			0204-1		
04161D	3123674300 (ME150064)	R		GASKET,OIL STRAINER	1	1					9006-1	9412-3	
	ME151865			GASKET,OIL STRAINER	1	1					9501-1		
	ME151865			GASKET,OIL STRAINER			1	1			9901-1		

オイルポンプ & ストレーナ
12-110 OIL PUMP & STRAINER

04 6D240 CTJS04US1
03 6D240 CTJS04000
02 6D221 CTJS12131 COLD
01 6D221 CTJS12000 STD

-63-

見出番号 REF.-NO.	部品番号 PART NO.	代 替 R / P	変 更 順 号 S C E N E Q G	部品名称および記事・仕様記号 PART NAME & DESCRIPTION	型式・個数 MODEL & QTY					適用号機 APPLICABLE SERIAL NO. FROM@ : @UPTO	管 区 M / R	新 規 V / R D	
					0	1	2	3	4				
04178	MF300850			BOLT,OIL STRAINER WASHER ASSEMBLED,10X45	4	4					9006-1		
	MF300853			BOLT,OIL STRAINER WASHER ASSEMBLED,10X60			4	4			9901-1		
04178C	MF300843			BOLT,OIL STRAINER WASHER ASSEMBLED,10X25	2	2	2	2			9006-1		

オイルフィルタ
12-120 OIL FILTER

-64-

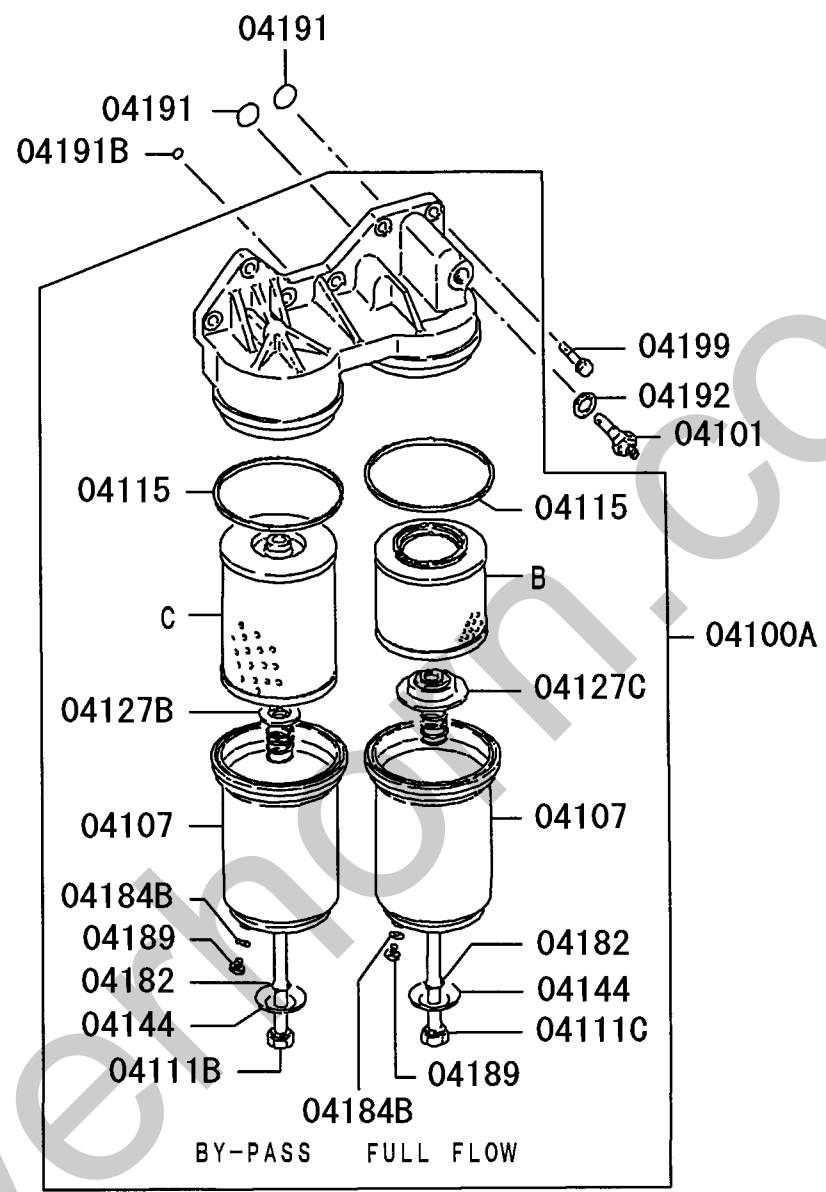

04180

04130	04140
PNC C, 04115, 04182, 04184B	PNC B, 04115, 04182, 04184B

C: ELEMET, BY-PASS

B: ELEMENT, FULL FLOW

217T01

オイルフィルタ
12-120 OIL FILTER

04 6D240 CTJS04US1
03 6D240 CTJS04000
02 6D221 CTJS12131 COLD
01 6D221 CTJS12000 STD

-65-

見出番号 REF.-NO.	部品番号 PART NO.	代 替 R / P	変 更 順 号 S C E N E Q G	部品名称および記事・仕様記号 PART NAME & DESCRIPTION	型式・個数 MODEL & QTY					適用号機 APPLICABLE SERIAL NO.		管 区 M / R	新 規 V R D	
					0	1	2	3	4	FROM@	-@UPTO			
04100A	ME054240 (ME121787)	R		OIL FILTER & HEAD ASSY	1	1					9006-1	9903-3		
	ME121787 (ME180513)	R		OIL FILTER & HEAD ASSY	1	1					9904-1	9910-3		
	ME180513			OIL FILTER & HEAD ASSY	1	1					9911-1			
	ME054240 (ME121787)	R		OIL FILTER & HEAD ASSY			1	1			9901-1	9903-3		
	ME121787 (ME180513)	R		OIL FILTER & HEAD ASSY			1	1			9904-1	9910-3		
	ME180513			OIL FILTER & HEAD ASSY			1	1			9911-1			
04101	ME054661			SWITCH,OIL FILTER BY-PASS	1	1	1	1			9006-1			
04107	3124051203			CASE,OIL FILTER	2	2	2	2			9006-1			
04111B	3124051500			CENTER BOLT,OIL FILTER 16X226	1	1					9006-1	9903-3		
	ME164716			CENTER BOLT,OIL FILTER 16X226	1	1					9904-1			
	3124051500			CENTER BOLT,OIL FILTER 16X226			1	1			9901-1	9903-3		
	ME164716			CENTER BOLT,OIL FILTER 16X226			1	1			9904-1			
04111C	3124050500		CENTER BOLT,OIL FILTER 16X165	1	1	1	1			9006-1				
04115	3124050301 (ME121800)	3		GASKET,OIL FILTER CASE	2	2					9006-1	9907-3		
	ME121800			GASKET,OIL FILTER CASE	2	2					9908-1			
	3124050301 (ME121800)	3		GASKET,OIL FILTER CASE			2	2			9901-1	9907-3		
	ME121800			GASKET,OIL FILTER CASE			2	2			9908-1			
04127B	ME054156			RETAINER,OIL FILTER ELEMENT	1	1	1	1			9006-1			
04127C	ME054082			RETAINER,OIL FILTER ELEMENT	1	1	1	1			9006-1			
04130	ME054238			ELEMENT KIT,BY-PASS OIL FILTER	1	1					9006-1	9901-3		
	ME164857			ELEMENT KIT,BY-PASS OIL FILTER	1	1					9902-1			
	ME054238			ELEMENT KIT,BY-PASS OIL FILTER			1	1			9901-1	9901-3		
	ME164857			ELEMENT KIT,BY-PASS OIL FILTER			1	1			9902-1			
04140	3124053054 (ME121788)	3		ELEMENT KIT,OIL FILTER	1	1					9006-1	9901-3		
	ME121788			ELEMENT KIT,OIL FILTER	1	1					9902-1			
	3124053054 (ME121788)	3		ELEMENT KIT,OIL FILTER			1	1			9901-1	9901-3		
	ME121788			ELEMENT KIT,OIL FILTER			1	1			9902-1			
04144	3124053900		WASHER,OIL FILTER PLAIN,16.5	2	2	2	2			9006-1				
04180	ME054334			ELEMENT KIT,MAIN & BY-PASS OIL FILTER	1	1					9006-1	9901-3		
	ME121789			ELEMENT KIT,MAIN & BY-PASS OIL FILTER	1	1					9902-1	9910-3		
	ME180514			ELEMENT KIT,MAIN & BY-PASS OIL FILTER	1	1					9911-1			
	ME054334			ELEMENT KIT,MAIN & BY-PASS OIL FILTER			1	1			9901-1	9901-3		
	ME121789			ELEMENT KIT,MAIN & BY-PASS OIL FILTER			1	1			9902-1	9910-3		
04182	ME180514			ELEMENT KIT,MAIN & BY-PASS OIL FILTER			1	1			9911-1			
	MH035025			O-RING,OIL FILTER INR 16	2	2	2	2			9006-1			

オイルフィル
12-120 OIL FILTER

04 6D240 CTJS04US1
03 6D240 CTJS04000
02 6D221 CTJS12131 COLD
01 6D221 CTJS12000 STD

-66-

見出番号 REF.-NO.	部品番号 PART NO.	代 替 R / P	変 更 順 号 S C E N E Q G	部品名称および記事・仕様記号 PART NAME & DESCRIPTION	型式・個数 MODEL & QTY				適用号機 APPLICABLE SERIAL NO.		管 区 M / R	新 規 V R D
					0	1	2	3	4	FROM@		
04184B	F420210000			GASKET,OIL FILTER INR 10	2	2	2	2			9006-1	
04189	3124050900 (F500010000)	3		PLUG,OIL FILTER	2	2	2	2			9006-1	
04191	3113902201			O-RING,OIL FILTER 24	2	2	2	2			9006-1	
04191B	3124054500			O-RING,OIL FILTER 10.8	1	1	1	1			9006-1	
04192	F420220000			GASKET,OIL FILTER 20	1	1	1	1			9006-1	
04199	MH000715			BOLT,OIL FILTER FLANGE,10X35	7	7					9006-1	9909-3
	MS146010			BOLT,OIL FILTER FLANGE,10X35	7	7					9910-1	
	MH000715			BOLT,OIL FILTER FLANGE,10X35			7	7			9901-1	9909-3
	MS146010			BOLT,OIL FILTER FLANGE,10X35			7	7			9910-1	

オイルクーラ
12-130 OIL COOLER

-68-

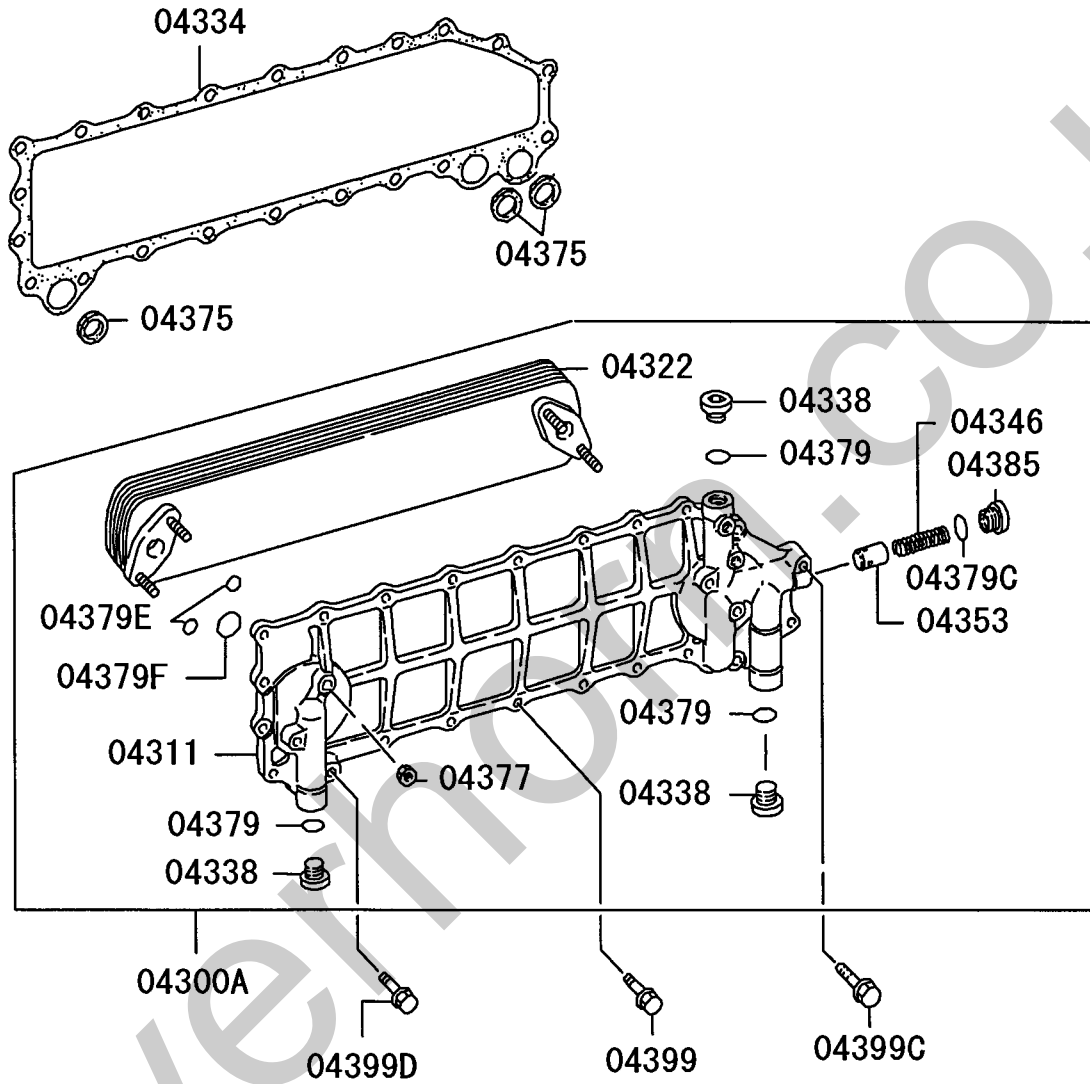

217T02

-9405・3

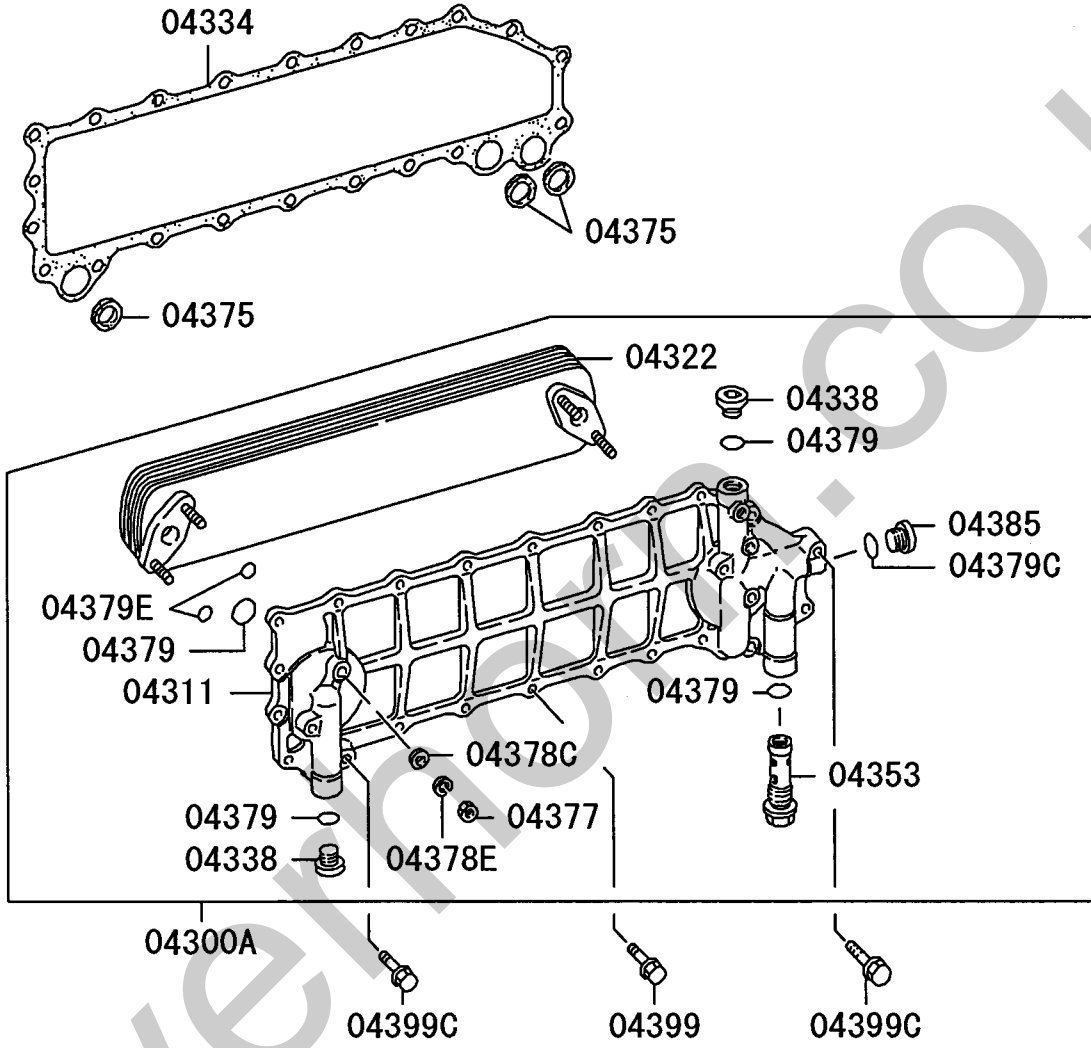

オイルクーラ
12-130 OIL COOLER

04 6D240 CTJS04US1
03 6D240 CTJS04000
02 6D221 CTJS12131 COLD
01 6D221 CTJS12000 STD

-70-

見出番号 REF.-NO.	部品番号 PART NO.	代 替 R / P	変 更 順 号 S C E N E Q G	部品名称および記事・仕様記号 PART NAME & DESCRIPTION	型式・個数 MODEL & QTY						適用号機 APPLICABLE SERIAL NO.		管 区 M / R	新 規 V R D
					0	1	2	3	4	FROM@	@UPTO			
04300A	ME054547 (ME150866)	3		OIL COOLER ASSY,ENG	1	1					9006-1	9405-3		
	ME150866	#		OIL COOLER ASSY,ENG T01015	1	1					9406-1			
	ME150453			OIL COOLER ASSY,ENG			1	1			9901-1			
04311	ME054549	#		COVER,ENG OIL COOLER T03114	1	1					9006-1	9405-3		
04322	ME150441			COVER,ENG OIL COOLER	1	1					9406-1			
	ME150441			COVER,ENG OIL COOLER			1	1			9901-1			
	ME054110			ELEMENT,ENG OIL COOLER	1	1					9006-1	9405-3		
	ME150921 (ME153170)	R		ELEMENT,ENG OIL COOLER	1	1					9406-1	9901-3		
	ME153170			ELEMENT,ENG OIL COOLER	1	1					9902-1			
	ME150440 (ME153172)	R		ELEMENT,ENG OIL COOLER			1	1			9901-1	9901-3		
04334	ME153172			ELEMENT,ENG OIL COOLER			1	1			9902-1			
	ME054669 (ME150682)	3		GASKET,ENG OIL COOLER COVER	1	1					9006-1	9412-3		
	ME150682			GASKET,ENG OIL COOLER COVER	1	1					9501-1			
04338	ME150682			GASKET,ENG OIL COOLER COVER			1	1			9901-1			
	ME064526	#		PLUG,ENG OIL COOLER SCREW,27 T03114	2	2					9006-1	9405-3		
	ME064526	#		PLUG,ENG OIL COOLER SCREW,27 T03114	3	3					9406-1			
04346	ME064526	#		PLUG,ENG OIL COOLER SCREW,27 T03114			3	3			9901-1			
	ME150443 (ME153173)	R		SPRING,ENG OIL COOLER BY-PASS VALVE	1	1					9406-1	9901-3		
	ME153173			SPRING,ENG OIL COOLER BY-PASS VALVE	1	1					9902-1			
04353	ME150443 (ME153173)	R		SPRING,ENG OIL COOLER BY-PASS VALVE			1	1			9901-1	9901-3		
	ME153173			SPRING,ENG OIL COOLER BY-PASS VALVE			1	1			9902-1			
	ME054045	#		VALVE,ENG OIL COOLER BY-PASS T03114	1	1					9006-1	9405-3		
04375	ME084527			VALVE,ENG OIL COOLER BY-PASS	1	1					9406-1			
	ME084527			VALVE,ENG OIL COOLER BY-PASS			1	1			9901-1			
04377	3093900300			O-RING,ENG OIL COOLER 25	3	3	3	3			9006-1			
04378C	F230010000			NUT,ENG OIL COOLER INR 10	4	4					9006-1	9405-3		
	ME150442			NUT,ENG OIL COOLER INR 10	4	4					9406-1			
	ME150442			NUT,ENG OIL COOLER INR 10			4	4			9901-1			
04378E	F250010000			WASHER,ENG OIL COOLER INR PLAIN,10	4	4				9006-1	9405-3			
04379	F251510000			WASHER,ENG OIL COOLER INR SPRING,10	4	4				9006-1	9405-3			
04379	MH035093	R		O-RING,ENG OIL COOLER INR 25	5	5					9006-1	9405-3		

オイルクーラ
12 -130 OIL COOLER

04 6D240 CTJS04US1
03 6D240 CTJS04000
02 6D221 CTJS12131 COLD
01 6D221 CTJS12000 STD

-71-

見出番号 REF.-NO.	部品番号 PART NO.	代 替 R / P	変 更 順 号 S C E N E Q G	部品名称および記事・仕様記号 PART NAME & DESCRIPTION	型式・個数 MODEL & QTY						適用号機 APPLICABLE SERIAL NO.		管 区 M / R	新 規 V R D
					0	1	2	3	4		FROM@	@UPTO		
	(MH035236) MH035093	R		O-RING,ENG OIL COOLER INR 25	3	3						9406-1		
	(MH035236) MH035093	R		O-RING,ENG OIL COOLER INR 25			3	3				9901-1		
04379C	(MH035236) F315001800			O-RING,ENG OIL COOLER INR 18	1	1						9006-1	9405-3	
	MH035044			O-RING,ENG OIL COOLER INR 18	1	1						9406-1		
	MH035044			O-RING,ENG OIL COOLER INR 18			1	1				9901-1		
04379E	MH035092			O-RING,ENG OIL COOLER INR 14	4	4	4	4				9006-1		
04379F	F315603000			O-RING,ENG OIL COOLER INR 30	2	2						9406-1	9506-3	
	MH035626			O-RING,ENG OIL COOLER INR 30	2	2						9507-1		
	MH035626			O-RING,ENG OIL COOLER INR 30			2	2				9901-1		
04385	MH037117			PLUG,ENG OIL COOLER INR 20	1	1						9006-1	9405-3	
	ME014717			PLUG,ENG OIL COOLER INR 20	1	1						9406-1		
	ME014717			PLUG,ENG OIL COOLER INR 20			1	1				9901-1		
04399	MH000714			BOLT,ENG OIL COOLER FLANGE,10X25	18	18						9006-1	9502-3	
	MH000707			BOLT,ENG OIL COOLER FLANGE,10X30	2	2						9006-1	9502-3	
	MS146006			BOLT,ENG OIL COOLER FLANGE,10X25	18	18						9503-1		
	MS146008			BOLT,ENG OIL COOLER FLANGE,10X30	2	2						9503-1		
	MS146006			BOLT,ENG OIL COOLER FLANGE,10X25			19	19				9901-1		
	MS146008			BOLT,ENG OIL COOLER FLANGE,10X30			1	1				9901-1		
04399C	MH000709			BOLT,ENG OIL COOLER FLANGE,10X50	2	2						9006-1	9405-3	
	MH000709			BOLT,ENG OIL COOLER FLANGE,10X50	1	1						9406-1	9502-3	
	MS146016			BOLT,ENG OIL COOLER FLANGE,10X50	1	1						9503-1		
	MS146016			BOLT,ENG OIL COOLER FLANGE,10X50			1	1				9901-1		
04399D	MH000740			BOLT,ENG OIL COOLER FLANGE,10X42	1	1						9406-1	9502-3	
	MS146014			BOLT,ENG OIL COOLER	1	1						9503-1		

オイルライン
12-140 OIL LINE

-74-

FOR INJ PUMP & 1CYL A/COMPR

6D22-T

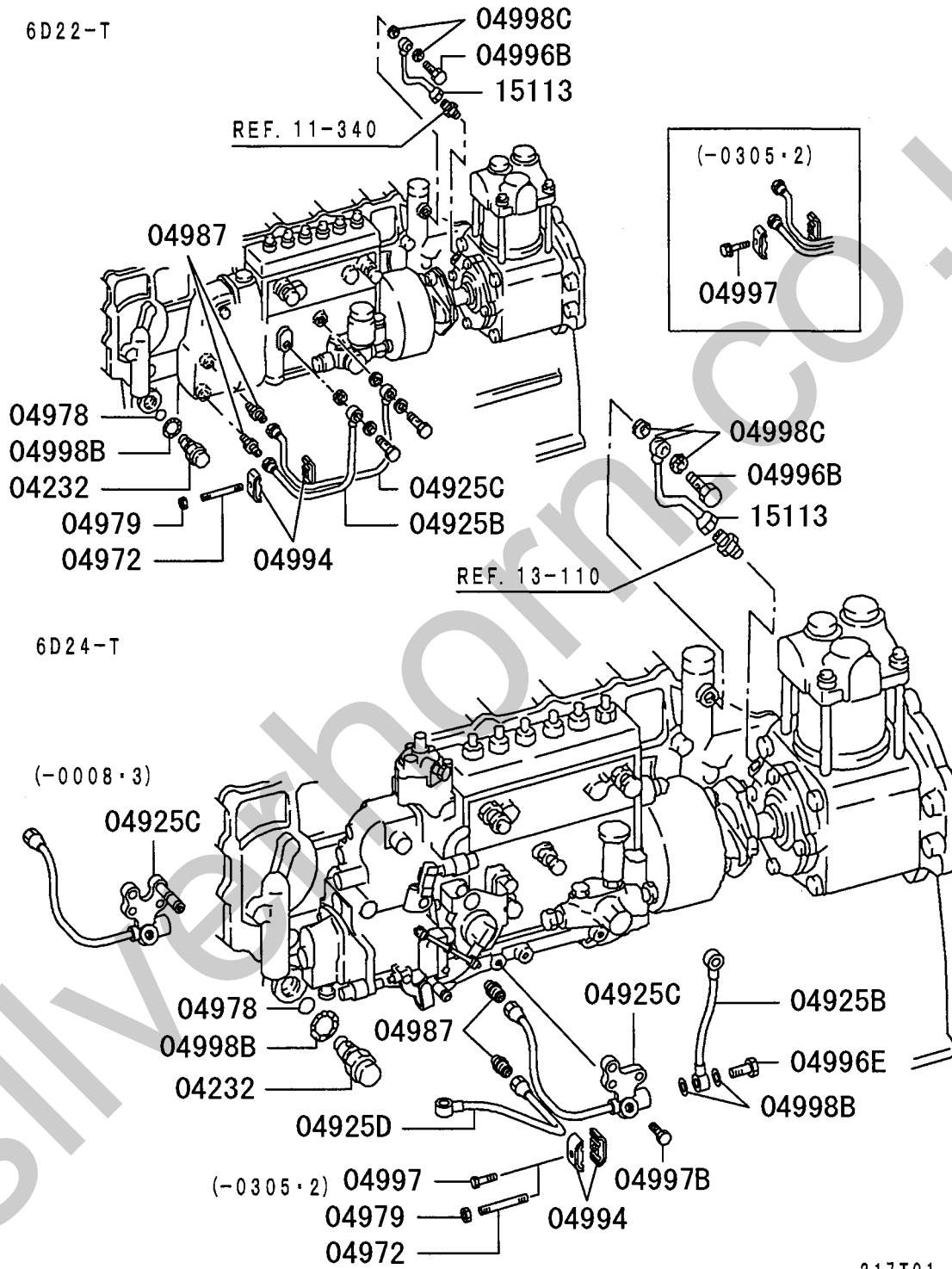

217T01

6D22-T (-9708・2)
6D24-T (9908・3-0002・3)

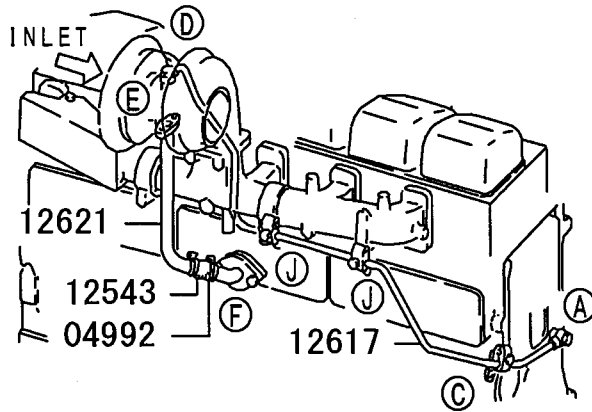

6D22-T (9708・3-0002・3)
6D24-T (-9908・2)

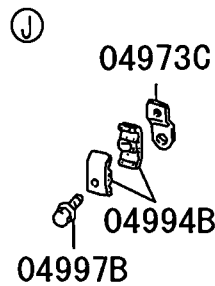
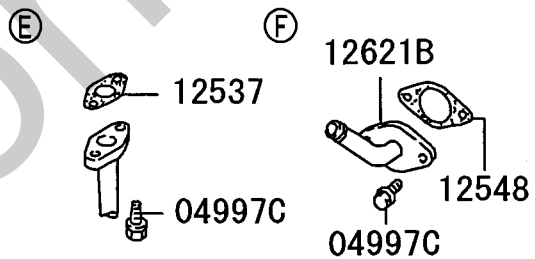
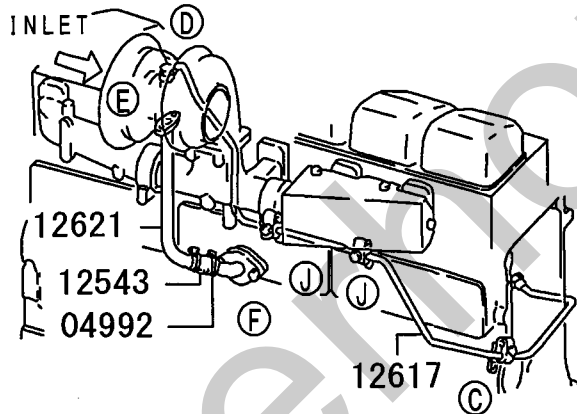
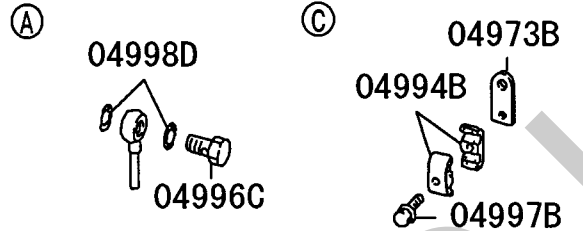

オイルライン
12-140 OIL LINE

04 6D240 CTJS04US1
03 6D240 CTJS04000
02 6D221 CTJS12131 COLD
01 6D221 CTJS12000 STD

-76-

見出番号 REF.-NO.	部品番号 PART NO.	代 替 順 号 R / S C E N P O G	部品名称および記事・仕様記号 PART NAME & DESCRIPTION	型式・個数 MODEL & QTY						適用号機 APPLICABLE SERIAL NO.		管 区 M / R	新 規 V R D
				0	1	2	3	4	FROM@	@UPTO			
04232	ME034545 (ME074455)	R	VALVE,ENG OIL PRESSURE REGULATING	1	1					9006-1	9401-3		
	ME074455		VALVE,ENG OIL PRESSURE REGULATING	1	1					9402-1			
	ME074455		VALVE,ENG OIL PRESSURE REGULATING			1	1			9901-1			
04925B	3093602300		TUBE,ENG OIL LINE	1	1					9006-1			
	ME054407		TUBE,ENG OIL LINE			1	1			9901-1			
04925C	ME058862		TUBE,ENG OIL LINE	1	1					9006-1	9412-3		
	ME158066		TUBE,ENG OIL LINE	1	1					9501-1			
	ME054545 (ME054525)	R	TUBE,ENG OIL LINE			1	1			9901-1	0008-3		
	ME054525		TUBE,ENG OIL LINE			1	1			0009-1			
04925D	ME054232		TUBE,ENG OIL LINE			1	1			9901-1			
04972	MF406251		STUD,ENG OIL LINE 6X35	1	1	1	1			0305-3			V
04973B	MH023119		STAY,ENG OIL LINE	1	1	1	1			9708-3	0002-3		
04973C	ME930001		STAY,ENG OIL LINE	2	2	2	2			9006-1			
04978	MH035129		O-RING,ENG OIL LINE 17.4	1	1	1	1			9006-1			
04979	MF434103		NUT,ENG OIL LINE FLANGE,6	1	1	1	1			0305-3			
04987	MH038906		JOINT,ENG OIL LINE	2	2	2	2			9006-1			
04992	MH021295		CLIP,ENG OIL LINE D=31	2	2	2	2			9006-1			
04994	MH021233		CLAMP,ENG OIL LINE D=6X2	2	2	2	2			9006-1			
04994B	MH021260		CLAMP,ENG OIL LINE D=9X2	6	6	6	6			9006-1			
04996B	MH037279		EYEBOLT,ENG OIL LINE 10X20	1	1	1	1			9006-1			
04996C	MH037087		EYEBOLT,ENG OIL LINE 14X26	1	1	1	1			9006-1	0002-3		
04996D	MH037716		EYEBOLT,ENG OIL LINE 10X26	1	1	1	1			9006-1			
04996E	F461012000 (MS650013)	3	EYEBOLT,ENG OIL LINE 12X23			1	1			9901-1			
04997	MF140011		BOLT,ENG OIL LINE FLANGE,6X30	1	1	1	1			9006-1	0305-2		
04997B	MF140013		BOLT,ENG OIL LINE FLANGE,6X35	3	3					9006-1	0006-3		
	MF140213		BOLT,ENG OIL LINE FLANGE,6X35	3	3					0007-1			
	MF140013		BOLT,ENG OIL LINE FLANGE,6X35			3	3			9901-1	0006-3		
	MF140027		BOLT,ENG OIL LINE FLANGE,8X25			2	2			9901-1			
	MF140213		BOLT,ENG OIL LINE FLANGE,6X35			3	3			0007-1			
04997C	MH000713	#	BOLT,ENG OIL LINE FLANGE,10X20 T02406A	4	4					9006-1	0306-2		

オイルライン
12-140 OIL LINE

04 6D240 CTJS04US1
03 6D240 CTJS04000
02 6D221 CTJS12131 COLD
01 6D221 CTJS12000 STD

-77-

見出番号 REF.-NO.	部品番号 PART NO.	代 替 R / P 記 順 号 S C E N E Q G	部品名称および記事・仕様記号 PART NAME & DESCRIPTION	型式・個数 MODEL & QTY						適用号機 APPLICABLE SERIAL NO.		管 区 M / R	新 規 V R D
				0	1	2	3	4		FROM@	@UPTO		
	MS146004		BOLT,ENG OIL LINE FLANGE,10X20	4	4						0306-3		
	MH000713	#	BOLT,ENG OIL LINE FLANGE,10X20 T02406A				4	4			9901-1	0306-2	
	MS146004		BOLT,ENG OIL LINE FLANGE,10X20				4	4			0306-3		
04998B	F420227000		GASKET,ENG OIL LINE 27	1	1						9006-1		
	F420212000		GASKET,ENG OIL LINE 12				2	2			9901-1		
	F420227000		GASKET,ENG OIL LINE 27				1	1			9901-1		
04998C	F420210000		GASKET,ENG OIL LINE 10	4	4	4	4				9006-1		
04998D	F420214000		GASKET,ENG OIL LINE 14	2	2	2	2				9006-1	0002-3	
12537	ME054744		GASKET,T/C OIL RETURN TUBE	1	1	1	1				9006-1		
12543	ME054279		HOSE,T/C OIL RETURN TUBE	1	1	1	1				9006-1		
12548	ME058961 (ME157194)	R	GASKET,T/C OIL RETURN PIPE TO CYLINDER B	1	1						9006-1	9412-3	
	ME157194		GASKET,T/C OIL RETURN PIPE TO CYLINDER B	1	1						9501-1		
12617	ME157194		GASKET,T/C OIL RETURN PIPE TO CYLINDER B				1	1			9901-1		
	ME059050		TUBE,T/C OIL FEED	1	1						9006-1	9708-2	
	ME059062		TUBE,T/C OIL FEED	1	1						9708-3	0002-3	
	ME159062		TUBE,T/C OIL FEED	1	1						0003-1		
	ME059062		TUBE,T/C OIL FEED				1	1			9901-1	9908-2	
	ME059050		TUBE,T/C OIL FEED				1	1			9908-3	0002-3	
	ME159062		TUBE,T/C OIL FEED				1	1			0003-1		
12621	ME157230		TUBE,T/C OIL RETURN	1	1	1	1				9006-1		
12621B	ME058983		TUBE,T/C OIL RETURN	1	1	1	1				9006-1		
15113	3093613500		TUBE,AIR COMPRESSOR OIL FEED	1	1	1	1				9006-1		

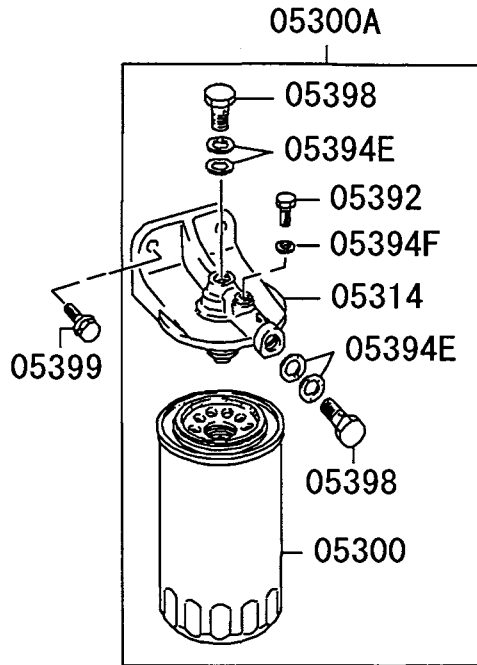

6D22-T

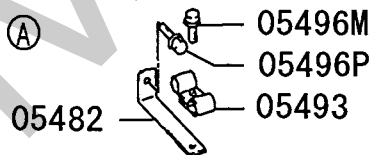
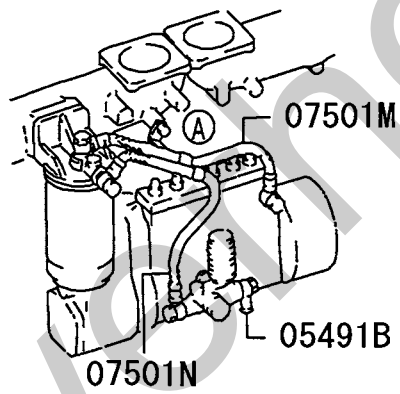

6D24-T

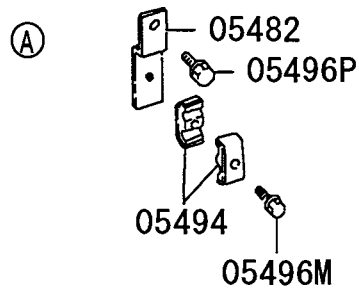
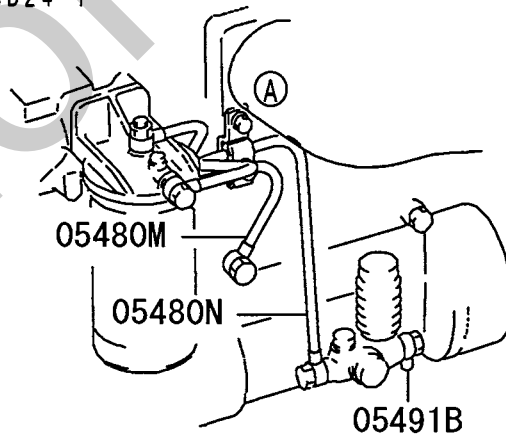

13 -030 FUEL FILTER & HOSE

フューエルフィルタ & ホース

04 6D240 CTJS04US1
 03 6D240 CTJS04000
 02 6D221 CTJS12131 COLD
 01 6D221 CTJS12000 STD

-79-

見出番号 REF.-NO.	部品番号 PART NO.	代 替 R I P	記 順 号 S C E N E P Q	部品名称および記事・仕様記号 PART NAME & DESCRIPTION	型式・個数 MODEL & QTY					適用号機 APPLICABLE SERIAL NO.		管 区 M / R	新 規 V R D
					0	1	2	3	4	FROM@	@UPTO		
05300	ME056670			FUEL FILTER	1	1	1	1			9006-1		
05300A	ME090010 (ME090012)	3		FUEL FILTER ASSY	1	1	1	1			9006-1		
05314	ME056279			HEAD,FUEL FILTER	1	1	1	1			9006-1		
05392	MH037084	3		PLUG,FUEL FILTER	1	1					9006-1	9301-3	
	(ME016894) ME016894			SCREW,8X9.5									
	ME016894			PLUG,FUEL FILTER	1	1					9302-1		
	ME016894			SCREW,8X9				1	1		9901-1		
	ME016894			PLUG,FUEL FILTER				1	1		9901-1		
	ME016894			SCREW,8X9				1	1		9901-1		
05394E	MH035166	3		GASKET,FUEL FILTER	4	4					9006-1	9602-3	
	(MH035069) MH035069			14									
	MH035069			GASKET,FUEL FILTER	4	4					9603-1		
	MH035069			14				4	4		9901-1		
05394F	MH035164			GASKET,FUEL FILTER	1	1					9006-1	9602-3	
	MH035067			8									
	MH035067			GASKET,FUEL FILTER	1	1					9603-1		
	MH035067			8									
	MH035067			GASKET,FUEL FILTER				1	1		9901-1		
	MH035067			8									
05398	MH037087			EYEBOLT,FUEL FILTER	2	2	2	2			9006-1		
	MH037087			14X26									
05399	MH000714			BOLT,FUEL FILTER	2	2					9006-1	0204-1	
	MS146006			FLANGE,10X25									
	MS146006			BOLT,FUEL FILTER	2	2					0204-2		
	MS146006			FLANGE,10X25									
	MH000714			BOLT,FUEL FILTER				2	2		9901-1	0204-1	
	MS146006			FLANGE,10X25									
	MS146006			BOLT,FUEL FILTER				2	2		0204-2		
	MS146006			FLANGE,10X25									
05480M	ME158184			TUBE,FUEL LINE				1	1		9901-1		
	ME158184			10									
05480N	ME158183			TUBE,FUEL LINE				1	1		9901-1		
	ME158183			10									
05482	ME930243			STAY,FUEL LINE	1	1					9006-1		
	ME930211			STAY,FUEL LINE							9901-1		
05491B	MH037116			JOINT,FUEL LINE	1	1	1	1			9006-1		
05493	MH020807			CLIP,FUEL LINE	2	2					9006-1		
	MH020807			D=16									
05494	MH021218			CLAMP,FUEL LINE				2	2		9901-1		
	MH021218			D=9X2									
05496M	MH000999			BOLT,FUEL LINE	1	1					9006-1		
	MH000999			FLANGE,6X12									
	MF140013			BOLT,FUEL LINE				1	1		9901-1	0006-3	
	MF140013			FLANGE,6X35									
	MF140213			BOLT,FUEL LINE				1	1		0007-1		

13-110 FUEL INJECTION PUMP GENERAL

フエイル インジェクション ポンプ ゼネラル

-82-

6D24-T

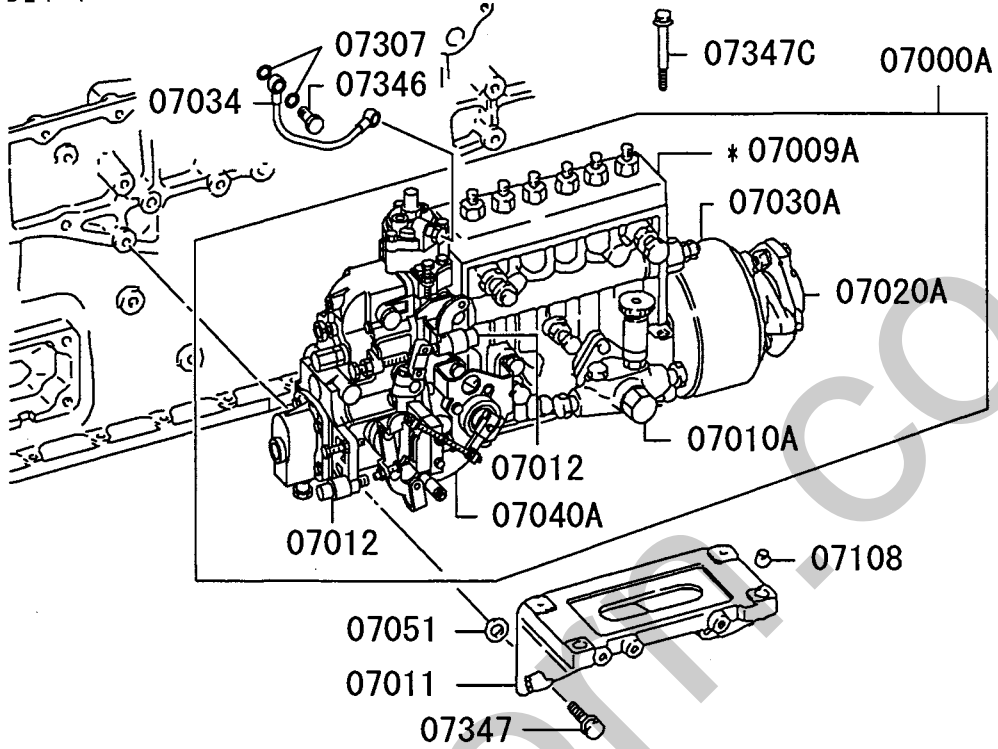

6D22-T

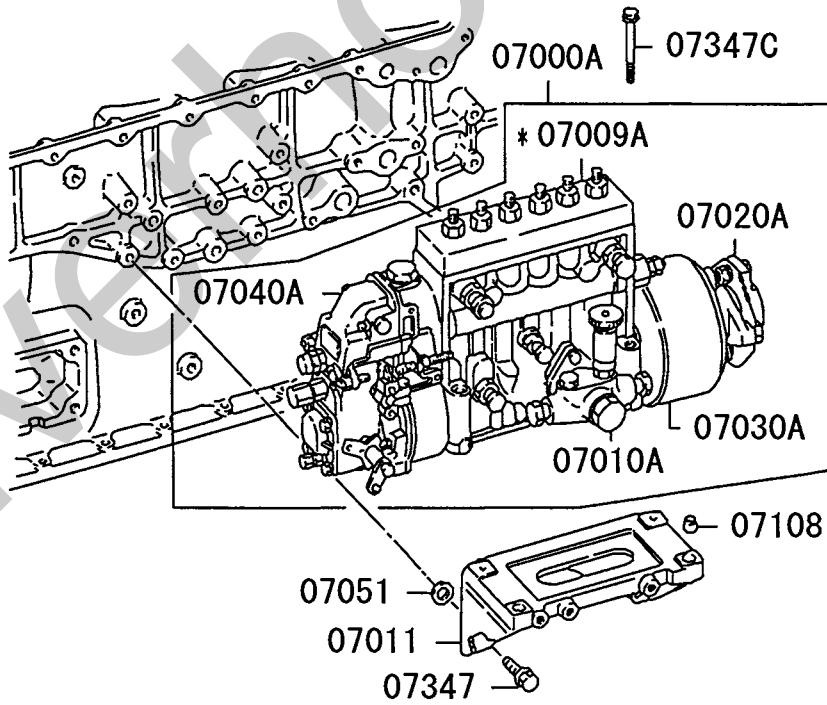

217T01

13-110 FUEL INJECTION PUMP GENERAL

フューエルインジェクションポンプゼネラル

04 6D240 CTJS04US1
 03 6D240 CTJS04000
 02 6D221 CTJS12131 COLD
 01 6D221 CTJS12000 STD

-83-

見出番号 REF.-NO.	部品番号 PART NO.	代 替 R / P	変 更 順 号 S C E N E Q G	部品名称および記事・仕様記号 PART NAME & DESCRIPTION	型式・個数 MODEL & QTY					適用号機 APPLICABLE SERIAL NO. FROM@-@UPTO	管 区 M / R D	新 規 V R D	
					0	1	2	3	4				
07000A	1066717821			PUMP ASSY,FUEL INJECTION ZEXEL	1	1					9006-1		
	1066762332			PUMP ASSY,FUEL INJECTION ZEXEL			1	1			9901-1		
07009A	*			BODY ASSY,INJECTION PUMP NS (ME059751)	1	1					9006-1		
	*			BODY ASSY,INJECTION PUMP NS (ME740548)			1	1			9901-1		
07010A	1052071210			PUMP ASSY,INJECTION PUMP FUEL FEED	1	1					9006-1		
	1052071200			PUMP ASSY,INJECTION PUMP FUEL FEED				1	1		9901-1		
07011	ME056381			BRACKET,INJECTION PUMP	1	1	1	1			9006-1		
07012	1540620400			CAP,INJECTION PUMP			2	2			9901-1		
07020A	1056620710			COUPLING ASSY,INJECTION PUMP	1	1					9006-1		
	1056630910			COUPLING ASSY,INJECTION PUMP			1	1			9901-1		
07030A	1056361820			TIMER ASSY,INJECTION PUMP	1	1					9006-1		
	1056812520			TIMER ASSY,INJECTION PUMP			1	1			9901-1		
07034	ME158107			PIPE,INJECTION PUMP BOOST COMPENSATOR			1	1			9901-1		
07040A	1054080410			GOVERNOR ASSY,INJECTION PUMP RSV	1	1					9006-1		
	1054877690			GOVERNOR ASSY,INJECTION PUMP RFD			1	1			9901-1		
07051	3016101200			SHIM,INJECTION PUMP BRACKET T=0.1	AR	AR	AR	AR			9006-1		
07108	MS471107			BUSHING,INJECTION PUMP BODY 10X9	2	2	2	2			9006-1		
07307	F420210000			GASKET,INJECTION PUMP FUEL FEED PUMP 10			2	2			9901-1		
07346	MH037279			EYEBOLT,INJECTION PUMP 10X20			1	1			9901-1		
07347	MH000715			BOLT,INJECTION PUMP FLANGE,10X35	4	4					9006-1	9910-3	
	MS146310			BOLT,INJECTION PUMP FLANGE,10X35	4	4					9911-1		
	MH000715			BOLT,INJECTION PUMP FLANGE,10X35			4	4			9901-1	9910-3	
	MS146310			BOLT,INJECTION PUMP FLANGE,10X35			4	4			9911-1		
07347C	MH000724			BOLT,INJECTION PUMP FLANGE,10X85	4	4					9006-1	0106-3	
	MS146023			BOLT,INJECTION PUMP FLANGE,10X85	4	4					0107-1		
	MH000724			BOLT,INJECTION PUMP FLANGE,10X85			4	4			9901-1	0106-3	
	MS146023			BOLT,INJECTION PUMP FLANGE,10X85			4	4			0107-1		

インジェクションポンプ
13-120 INJECTION PUMP

-84-

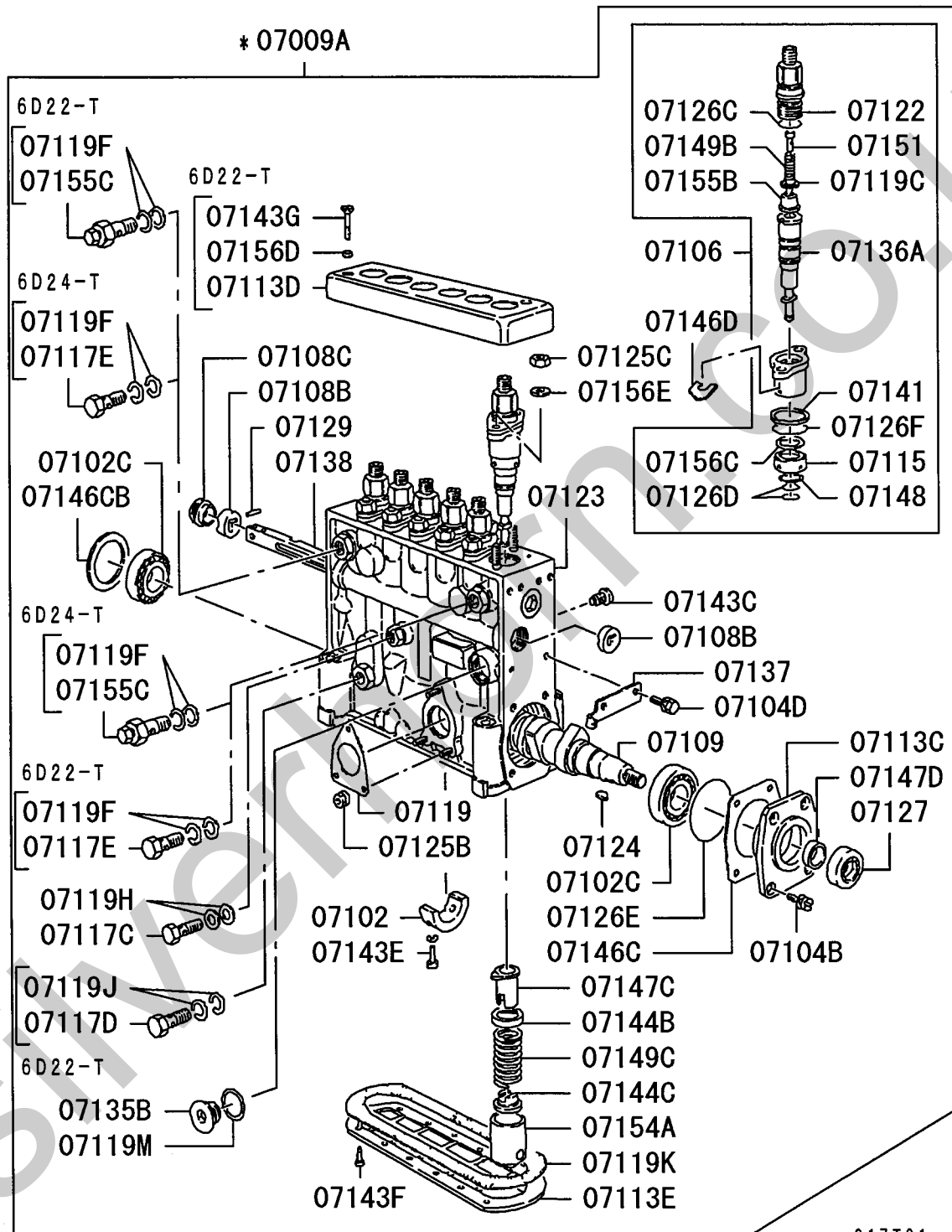

217T01

13-120 INJECTION PUMP

インジェクションポンプ

04 6D240 CTJS04US1
 03 6D240 CTJS04000
 02 6D221 CTJS12131 COLD
 01 6D221 CTJS12000 STD

-85-

見出番号 REF.-NO.	部品番号 PART NO.	代 替 R / P	変 更 順 号 S C E N E O G	部品名称および記事・仕様記号 PART NAME & DESCRIPTION	型式・個数 MODEL & QTY					適用号機 APPLICABLE SERIAL NO. FROM@-@UPTO	管 区 M / R	新 規 V R D
					0	1	2	3	4			
07009A	*			BODY ASSY,INJECTION PUMP NS (ME059751)	1	1				9006-1		
	*			BODY ASSY,INJECTION PUMP NS (ME740548)			1	1		9901-1		
07102	1343060100			BEARING,INJECTION PUMP BODY	1	1	1	1		9006-1		
07102C	0166502230			BEARING,INJECTION PUMP BODY	2	2	2	2		9006-1		
07104B	0290106810			BOLT,INJECTION PUMP BODY	4	4	4	4		9006-1		
07104D	0200061240			BOLT,INJECTION PUMP BODY	2	2	2	2		9006-1		
07106	1341438320			BLOCK,INJECTION PUMP BODY	6	6				9006-1		
	1341505820			BLOCK,INJECTION PUMP BODY			6	6		9901-1		
07108B	1340010000			BUSHING,INJECTION PUMP BODY	2	2	2	2		9006-1		
07108C	1342220000			BUSHING,INJECTION PUMP BODY	1	1	1	1		9006-1		
07109	1343712800			CAMSHAFT,INJECTION PUMP BODY	1	1	1	1		9006-1		
07113C	1343161700			COVER,INJECTION PUMP BODY	1	1	1	1		9006-1		
07113D	1344160100			COVER,INJECTION PUMP BODY	1	1				9006-1		
07113E	1340430800			COVER,INJECTION PUMP BODY	1	1	1	1		9006-1		
07115	1341350200			DEFLECTOR,INJECTION PUMP BODY	6	6	6	6		9006-1		
07117C	0297310180			EYEBOLT,INJECTION PUMP BODY	1	1	1	1		9006-1		
07117D	0297314680			EYEBOLT,INJECTION PUMP BODY	1	1				9006-1		
07117E	0297314570			EYEBOLT,INJECTION PUMP BODY	1	1				9006-1		
	0297314680			EYEBOLT,INJECTION PUMP BODY			1	1		9901-1		
07119	1310410500	R		GASKET,INJECTION PUMP BODY	1	1				9006-1		
	(1310410800)											
	1310410800			GASKET,INJECTION PUMP BODY			1	1		9901-1		
07119C	1341150100			GASKET,INJECTION PUMP BODY	6	6	6	6		9006-1		
07119F	0293414130			GASKET,INJECTION PUMP BODY	4	4	4	4		9006-1		
07119H	0265101340			GASKET,INJECTION PUMP BODY	2	2	2	2		9006-1		
07119J	0265141840			GASKET,INJECTION PUMP BODY	2	2				9006-1		
07119K	1340420100	R		GASKET,INJECTION PUMP BODY	1	1				9006-1		
	(1340421400)											
	1340421400			GASKET,INJECTION PUMP BODY			1	1		9901-1		
07119M	0265242940			GASKET,INJECTION PUMP BODY	1	1	1	1		9006-1		
07122	1341162400			HOLDER,INJECTION PUMP BODY	6	6	6	6		9006-1		
07123	1340009321			HOUSING,INJECTION PUMP BODY	1	1				9006-1		
	1340631720			HOUSING,INJECTION PUMP BODY			1	1		9901-1		
07124	0258051910			KEY,INJECTION PUMP BODY	1	1	1	1		9006-1		
07125B	1392060400			NUT,INJECTION PUMP BODY	3	3	3	3		9006-1		
07125C	0130210040			NUT,INJECTION PUMP BODY 10X8	12	12	12	12		9006-1		
07126C	0296322070	3		O-RING,INJECTION PUMP BODY	6	6	6	6		9006-1		
	(1397220400)											
07126D	0296315020	3		O-RING,INJECTION PUMP BODY	12	12	12	12		9006-1		
	(1397150400)											
07126E	0296355010			O-RING,INJECTION PUMP BODY	1	1	1	1		9006-1		
07126F	0296329030	3		O-RING,INJECTION PUMP BODY	6	6	6	6		9006-1		
	(1397290400)											
07127	1396250000			OIL SEAL,INJECTION PUMP BODY	1	1	1	1		9006-1		
07129	0240302030			PIN,INJECTION PUMP BODY	1	1	1	1		9006-1		
07135B	1340450100			PLUG,INJECTION PUMP BODY	1	1	1	1		9006-1		
07136A	1341512920			PLUNGER ASSY,INJECTION PUMP BODY	6	6				9006-1		

13 -120 INJECTION PUMP

インジェクションポンプ

04 6D240 CTJS04US1
 03 6D240 CTJS04000
 02 6D221 CTJS12131 COLD
 01 6D221 CTJS12000 STD

-86-

見出番号 REF.-NO.	部品番号 PART NO.	代 替 順 号 R / S C E N P / O G	部品名称および記事・仕様記号 PART NAME & DESCRIPTION	型式・個数 MODEL & QTY						適用号機 APPLICABLE SERIAL NO.	管 区 M / R	新 規 V R D	
				0	1	2	3	4		FROM@-@UPTO			
07137	1341534120		PLUNGER ASSY,INJECTION PUMP BODY				6	6			9901-1		
07138	1344960600		POINTER,INJECTION PUMP BODY	1	1	1	1				9006-1		
07141	1342560000		RACK,INJECTION PUMP BODY	1	1	1	1				9006-1		
	* *		RING,INJECTION PUMP BODY	6	6						9006-1		
	1341370100		RING,INJECTION PUMP BODY				6	6			9901-1		
07143C	1340470000		SCREW,INJECTION PUMP BODY	6	6	6	6				9006-1		
07143E	0201062040		SCREW,INJECTION PUMP BODY	2	2	2	2				9006-1		
07143F	0122061640		SCREW,INJECTION PUMP BODY	12	12	12	12				9006-1		
07143G	0213063010		SCREW,INJECTION PUMP BODY	2	2						9006-1		
07144B	1342160000		SEAT,INJECTION PUMP BODY	6	6	6	6				9006-1		
07144C	1342170000		SEAT,INJECTION PUMP BODY	6	6						9006-1		
	1342170500		SEAT,INJECTION PUMP BODY				6	6			9901-1		
07146C	1343140000		SHIM,INJECTION PUMP BODY T=0.100	CC	CC						9006-1		
	1343140100		SHIM,INJECTION PUMP BODY T=0.120	CC	CC						9006-1		
	1343140200		SHIM,INJECTION PUMP BODY T=0.140	CC	CC						9006-1		
	1343140300		SHIM,INJECTION PUMP BODY T=0.160	CC	CC						9006-1		
	1343140400		SHIM,INJECTION PUMP BODY T=0.180	CC	CC						9006-1		
	1343140500		SHIM,INJECTION PUMP BODY T=0.300	CC	CC						9006-1		
	1343140600		SHIM,INJECTION PUMP BODY T=0.500	CC	CC						9006-1		
	1343140000		SHIM,INJECTION PUMP BODY T=0.100				CC	CC			9901-1		
	1343140100		SHIM,INJECTION PUMP BODY T=0.120				CC	CC			9901-1		
	1343140200		SHIM,INJECTION PUMP BODY T=0.140				CC	CC			9901-1		
	1343140300		SHIM,INJECTION PUMP BODY T=0.160				CC	CC			9901-1		
	1343140400		SHIM,INJECTION PUMP BODY T=0.180				CC	CC			9901-1		
	1343140500		SHIM,INJECTION PUMP BODY T=0.300				CC	CC			9901-1		
	1343140600		SHIM,INJECTION PUMP BODY T=0.500				CC	CC			9901-1		
07146CB	1343030400		SHIM,INJECTION PUMP BODY T=0.600	CC	CC						9006-1		
	1343030000		SHIM,INJECTION PUMP BODY T=1.200	CC	CC						9006-1		
	1343030100		SHIM,INJECTION PUMP BODY T=1.500	CC	CC						9006-1		
	1343030200		SHIM,INJECTION PUMP BODY T=1.800	CC	CC						9006-1		
	1343030300		SHIM,INJECTION PUMP BODY T=2.000	CC	CC						9006-1		

13-120 INJECTION PUMP

インジェクションポンプ

04 6D240 CTJS04US1
 03 6D240 CTJS04000
 02 6D221 CTJS12131 COLD
 01 6D221 CTJS12000 STD

-87-

見出番号 REF.-NO.	部品番号 PART NO.	代 替 順 号 R / P SC EN Q G	部品名称および記事・仕様記号 PART NAME & DESCRIPTION	型式・個数 MODEL & QTY						適用号機 APPLICABLE SERIAL NO.	新 規 区 区 M / R D
				0	1	2	3	0	4		
				FROM@- :@UPTO							
	1343030400		SHIM,INJECTION PUMP BODY T=0.600			CC	CC		9901-1		
	1343030000		SHIM,INJECTION PUMP BODY T=1.200			CC	CC		9901-1		
	1343030100		SHIM,INJECTION PUMP BODY T=1.500			CC	CC		9901-1		
	1343030200		SHIM,INJECTION PUMP BODY T=1.800			CC	CC		9901-1		
	1343030300		SHIM,INJECTION PUMP BODY T=2.000			CC	CC		9901-1		
07146D	1394000900		SHIM,INJECTION PUMP BODY T=0.500	CC	CC				9006-1		
	1394001000		SHIM,INJECTION PUMP BODY T=0.525	CC	CC				9006-1		
	1394001100		SHIM,INJECTION PUMP BODY T=0.550	CC	CC				9006-1		
	1394001200		SHIM,INJECTION PUMP BODY T=0.575	CC	CC				9006-1		
	1394001300		SHIM,INJECTION PUMP BODY T=0.600	CC	CC				9006-1		
	1394001400		SHIM,INJECTION PUMP BODY T=0.625	CC	CC				9006-1		
	1394001500		SHIM,INJECTION PUMP BODY T=0.650	CC	CC				9006-1		
	1394001600		SHIM,INJECTION PUMP BODY T=0.675	CC	CC				9006-1		
	1394001700		SHIM,INJECTION PUMP BODY T=0.700	CC	CC				9006-1		
	1394001800		SHIM,INJECTION PUMP BODY T=0.725	CC	CC				9006-1		
	1394001900		SHIM,INJECTION PUMP BODY T=0.750	CC	CC				9006-1		
	1394002000		SHIM,INJECTION PUMP BODY T=0.775	CC	CC				9006-1		
	1394002100		SHIM,INJECTION PUMP BODY T=0.800	CC	CC				9006-1		
	1394002200		SHIM,INJECTION PUMP BODY T=0.825	CC	CC				9006-1		
	1394002300		SHIM,INJECTION PUMP BODY T=0.850	CC	CC				9006-1		
	1394002400		SHIM,INJECTION PUMP BODY T=0.875	CC	CC				9006-1		
	1394002500		SHIM,INJECTION PUMP BODY T=0.900	CC	CC				9006-1		
	1394002600		SHIM,INJECTION PUMP BODY T=0.925	CC	CC				9006-1		
	1394002700		SHIM,INJECTION PUMP BODY T=0.950	CC	CC				9006-1		
	1394002800		SHIM,INJECTION PUMP BODY T=0.975	CC	CC				9006-1		

13 -120 INJECTION PUMP

インジェクションポンプ

04 6D240 CTJS04US1
 03 6D240 CTJS04000
 02 6D221 CTJS12131 COLD
 01 6D221 CTJS12000 STD

-88-

見出番号 REF.-NO.	部品番号 PART NO.	代 替 R / P 記 順 号 S C E N E P O G	部品名称および記事・仕様記号 PART NAME & DESCRIPTION	型式・個数 MODEL & QTY						適用号機 APPLICABLE SERIAL NO.		管 区 M / R	新 規 V R D
				0	1	2	3	4		FROM@	@UPTO		
	1394002900		SHIM,INJECTION PUMP BODY T=1.000	CC	CC						9006-1		
	1394003000		SHIM,INJECTION PUMP BODY T=1.025	CC	CC						9006-1		
	1394003100		SHIM,INJECTION PUMP BODY T=1.050	CC	CC						9006-1		
	1394003200		SHIM,INJECTION PUMP BODY T=1.075	CC	CC						9006-1		
	1394003300		SHIM,INJECTION PUMP BODY T=1.100	CC	CC						9006-1		
	1394003400		SHIM,INJECTION PUMP BODY T=1.125	CC	CC						9006-1		
	1394003500		SHIM,INJECTION PUMP BODY T=1.150	CC	CC						9006-1		
	1394003600		SHIM,INJECTION PUMP BODY T=1.175	CC	CC						9006-1		
	1394003700		SHIM,INJECTION PUMP BODY T=1.200	CC	CC						9006-1		
	1394003800		SHIM,INJECTION PUMP BODY T=1.225	CC	CC						9006-1		
	1394003900		SHIM,INJECTION PUMP BODY T=1.250	CC	CC						9006-1		
	1394004000		SHIM,INJECTION PUMP BODY T=1.275	CC	CC						9006-1		
	1394004100		SHIM,INJECTION PUMP BODY T=1.300	CC	CC						9006-1		
	1394004200		SHIM,INJECTION PUMP BODY T=1.325	CC	CC						9006-1		
	1394004300		SHIM,INJECTION PUMP BODY T=1.350	CC	CC						9006-1		
	1394004400		SHIM,INJECTION PUMP BODY T=1.375	CC	CC						9006-1		
	1394004500		SHIM,INJECTION PUMP BODY T=1.400	CC	CC						9006-1		
	1394004600		SHIM,INJECTION PUMP BODY T=1.425	CC	CC						9006-1		
	1394004700		SHIM,INJECTION PUMP BODY T=1.450	CC	CC						9006-1		
	1394004800		SHIM,INJECTION PUMP BODY T=1.475	CC	CC						9006-1		
	1394004900		SHIM,INJECTION PUMP BODY T=1.500	CC	CC						9006-1		
	1394005000		SHIM,INJECTION PUMP BODY T=1.525	CC	CC						9006-1		
	1394005100		SHIM,INJECTION PUMP BODY T=1.550	CC	CC						9006-1		
	1394005200		SHIM,INJECTION PUMP BODY T=1.575	CC	CC						9006-1		
	1394005300		SHIM,INJECTION PUMP BODY T=1.600	CC	CC						9006-1		

インジェクションポンプ
13-120 INJECTION PUMP

04 6D240 CTJS04US1
03 6D240 CTJS04000
02 6D221 CTJS12131 COLD
01 6D221 CTJS12000 STD

-89-

見出番号 REF.-NO.	部品番号 PART NO.	代 替 R I P 変 更 順 号 S C E N E Q G	部品名称および記事・仕様記号 PART NAME & DESCRIPTION	型式・個数 MODEL & QTY						適用号機 APPLICABLE SERIAL NO. FROM@-@UPTO	管 区 M / R 新 規 V R D
				0	1	2	3	4			
	1394005400		SHIM,INJECTION PUMP BODY T=1.625	CC	CC					9006-1	
	1394005500		SHIM,INJECTION PUMP BODY T=1.650	CC	CC					9006-1	
	1394005600		SHIM,INJECTION PUMP BODY T=1.675	CC	CC					9006-1	
	1394005700		SHIM,INJECTION PUMP BODY T=1.700	CC	CC					9006-1	
	1394005800		SHIM,INJECTION PUMP BODY T=1.725	CC	CC					9006-1	
	1394005900		SHIM,INJECTION PUMP BODY T=1.750	CC	CC					9006-1	
	1394006000		SHIM,INJECTION PUMP BODY T=1.775	CC	CC					9006-1	
	1394006100		SHIM,INJECTION PUMP BODY T=1.800	CC	CC					9006-1	
	1394006200		SHIM,INJECTION PUMP BODY T=1.825	CC	CC					9006-1	
	1394006300		SHIM,INJECTION PUMP BODY T=1.850	CC	CC					9006-1	
	1394006400		SHIM,INJECTION PUMP BODY T=1.875	CC	CC					9006-1	
	1394006500		SHIM,INJECTION PUMP BODY T=1.900	CC	CC					9006-1	
	1394006600		SHIM,INJECTION PUMP BODY T=1.925	CC	CC					9006-1	
	1394006700		SHIM,INJECTION PUMP BODY T=1.950	CC	CC					9006-1	
	1394006800		SHIM,INJECTION PUMP BODY T=1.975	CC	CC					9006-1	
	1394000900		SHIM,INJECTION PUMP BODY T=0.500			CC	CC			9901-1	
	1394001000		SHIM,INJECTION PUMP BODY T=0.525			CC	CC			9901-1	
	1394001100		SHIM,INJECTION PUMP BODY T=0.550			CC	CC			9901-1	
	1394001200		SHIM,INJECTION PUMP BODY T=0.575			CC	CC			9901-1	
	1394001300		SHIM,INJECTION PUMP BODY T=0.600			CC	CC			9901-1	
	1394001400		SHIM,INJECTION PUMP BODY T=0.625			CC	CC			9901-1	
	1394001500		SHIM,INJECTION PUMP BODY T=0.650			CC	CC			9901-1	
	1394001600		SHIM,INJECTION PUMP BODY T=0.675			CC	CC			9901-1	
	1394001700		SHIM,INJECTION PUMP BODY T=0.700			CC	CC			9901-1	
	1394001800		SHIM,INJECTION PUMP BODY T=0.725			CC	CC			9901-1	

インジェクションポンプ
13-120 INJECTION PUMP

04 6D240 CTJS04US1
03 6D240 CTJS04000
02 6D221 CTJS12131 COLD
01 6D221 CTJS12000 STD

-90-

見出番号 REF.-NO.	部品番号 PART NO.	代 替 R / P 変 更 順 号 S C E N E Q G	部品名称および記事・仕様記号 PART NAME & DESCRIPTION	型式・個数 MODEL & QTY				適用号機 APPLICABLE SERIAL NO. FROM@-@UPTO	管 区 M / R	新 規 V / R D
				0	1	2	3			
	1394001900		SHIM,INJECTION PUMP BODY T=0.750			CC	CC		9901.1	
	1394002000		SHIM,INJECTION PUMP BODY T=0.775			CC	CC		9901.1	
	1394002100		SHIM,INJECTION PUMP BODY T=0.800			CC	CC		9901.1	
	1394002200		SHIM,INJECTION PUMP BODY T=0.825			CC	CC		9901.1	
	1394002300		SHIM,INJECTION PUMP BODY T=0.850			CC	CC		9901.1	
	1394002400		SHIM,INJECTION PUMP BODY T=0.875			CC	CC		9901.1	
	1394002500		SHIM,INJECTION PUMP BODY T=0.900			CC	CC		9901.1	
	1394002600		SHIM,INJECTION PUMP BODY T=0.925			CC	CC		9901.1	
	1394002700		SHIM,INJECTION PUMP BODY T=0.950			CC	CC		9901.1	
	1394002800		SHIM,INJECTION PUMP BODY T=0.975			CC	CC		9901.1	
	1394002900		SHIM,INJECTION PUMP BODY T=1.000			CC	CC		9901.1	
	1394003000		SHIM,INJECTION PUMP BODY T=1.025			CC	CC		9901.1	
	1394003100		SHIM,INJECTION PUMP BODY T=1.050			CC	CC		9901.1	
	1394003200		SHIM,INJECTION PUMP BODY T=1.075			CC	CC		9901.1	
	1394003300		SHIM,INJECTION PUMP BODY T=1.100			CC	CC		9901.1	
	1394003400		SHIM,INJECTION PUMP BODY T=1.125			CC	CC		9901.1	
	1394003500		SHIM,INJECTION PUMP BODY T=1.150			CC	CC		9901.1	
	1394003600		SHIM,INJECTION PUMP BODY T=1.175			CC	CC		9901.1	
	1394003700		SHIM,INJECTION PUMP BODY T=1.200			CC	CC		9901.1	
	1394003800		SHIM,INJECTION PUMP BODY T=1.225			CC	CC		9901.1	
	1394003900		SHIM,INJECTION PUMP BODY T=1.250			CC	CC		9901.1	
	1394004000		SHIM,INJECTION PUMP BODY T=1.275			CC	CC		9901.1	
	1394004100		SHIM,INJECTION PUMP BODY T=1.300			CC	CC		9901.1	
	1394004200		SHIM,INJECTION PUMP BODY T=1.325			CC	CC		9901.1	
	1394004300		SHIM,INJECTION PUMP BODY T=1.350			CC	CC		9901.1	

インジェクションポンプ
13-120 INJECTION PUMP

04 6D240 CTJS04US1
03 6D240 CTJS04000
02 6D221 CTJS12131 COLD
01 6D221 CTJS12000 STD

見出番号 REF.-NO.	部品番号 PART NO.	代 替 R / P 変 更 順 号 S C E N A R I O G	部品名称および記事・仕様記号 PART NAME & DESCRIPTION	型式・個数 MODEL & QTY						適用号機 APPLICABLE SERIAL NO. FROM@-@UPTO	管 区 M / R	新 規 V R D	
				0	1	2	3	4					
	1394004400		SHIM,INJECTION PUMP BODY T=1.375				CC	CC			9901.1		
	1394004500		SHIM,INJECTION PUMP BODY T=1.400				CC	CC			9901.1		
	1394004600		SHIM,INJECTION PUMP BODY T=1.425				CC	CC			9901.1		
	1394004700		SHIM,INJECTION PUMP BODY T=1.450				CC	CC			9901.1		
	1394004800		SHIM,INJECTION PUMP BODY T=1.475				CC	CC			9901.1		
	1394004900		SHIM,INJECTION PUMP BODY T=1.500				CC	CC			9901.1		
	1394005000		SHIM,INJECTION PUMP BODY T=1.525				CC	CC			9901.1		
	1394005100		SHIM,INJECTION PUMP BODY T=1.550				CC	CC			9901.1		
	1394005200		SHIM,INJECTION PUMP BODY T=1.575				CC	CC			9901.1		
	1394005300		SHIM,INJECTION PUMP BODY T=1.600				CC	CC			9901.1		
	1394005400		SHIM,INJECTION PUMP BODY T=1.625				CC	CC			9901.1		
	1394005500		SHIM,INJECTION PUMP BODY T=1.650				CC	CC			9901.1		
	1394005600		SHIM,INJECTION PUMP BODY T=1.675				CC	CC			9901.1		
	1394005700		SHIM,INJECTION PUMP BODY T=1.700				CC	CC			9901.1		
	1394005800		SHIM,INJECTION PUMP BODY T=1.725				CC	CC			9901.1		
	1394005900		SHIM,INJECTION PUMP BODY T=1.750				CC	CC			9901.1		
	1394006000		SHIM,INJECTION PUMP BODY T=1.775				CC	CC			9901.1		
	1394006100		SHIM,INJECTION PUMP BODY T=1.800				CC	CC			9901.1		
	1394006200		SHIM,INJECTION PUMP BODY T=1.825				CC	CC			9901.1		
	1394006300		SHIM,INJECTION PUMP BODY T=1.850				CC	CC			9901.1		
	1394006400		SHIM,INJECTION PUMP BODY T=1.875				CC	CC			9901.1		
	1394006500		SHIM,INJECTION PUMP BODY T=1.900				CC	CC			9901.1		
	1394006600		SHIM,INJECTION PUMP BODY T=1.925				CC	CC			9901.1		
	1394006700		SHIM,INJECTION PUMP BODY T=1.950				CC	CC			9901.1		
	1394006800		SHIM,INJECTION PUMP BODY T=1.975				CC	CC			9901.1		

13-120 INJECTION PUMP

インジェクションポンプ

04 6D240 CTJS04US1
 03 6D240 CTJS04000
 02 6D221 CTJS12131 COLD
 01 6D221 CTJS12000 STD

-92-

見出番号 REF.-NO.	部品番号 PART NO.	代 替 順 号 R / P	変 記 順 号 S C E N Q G	部品名称および記事・仕様記号 PART NAME & DESCRIPTION	型式・個数 MODEL & QTY					適用号機 APPLICABLE SERIAL NO. FROM@- @UPTO	管 区 M / R	新 規 V R D
					0	1	2	3	4			
07147C	1342410021			SLEEVE,INJECTION PUMP BODY	6	6	6	6		9006-1		
07147D	1345630900			SLEEVE,INJECTION PUMP BODY	1	1	1	1		9006-1		
07148	0296020010			SNAP RING,INJECTION PUMP BODY	6	6	6	6		9006-1		
07149B	1341120600			SPRING,INJECTION PUMP BODY	6	6	6	6		9006-1		
07149C	1342150400			SPRING,INJECTION PUMP BODY	6	6	6	6		9006-1		
07151	1341171400			STOPPER,INJECTION PUMP BODY	6	6	6	6		9006-1		
07154A	1342000020			TAPPET ASSY,INJECTION PUMP BODY	6	6	6	6		9006-1		
07155B	1341104520			VALVE,INJECTION PUMP BODY	6	6	6	6		9006-1		
07155C	1314244620			VALVE,INJECTION PUMP BODY	1	1	1	1		9006-1		
07156C	0293020140			WASHER,INJECTION PUMP BODY	6	6	6	6		9006-1		
07156D	0145306540			WASHER,INJECTION PUMP BODY	2	2				9006-1		
07156E	1341320300			WASHER,INJECTION PUMP BODY	12	12	12	12		9006-1		

1-1/2

6D22-T

07040A

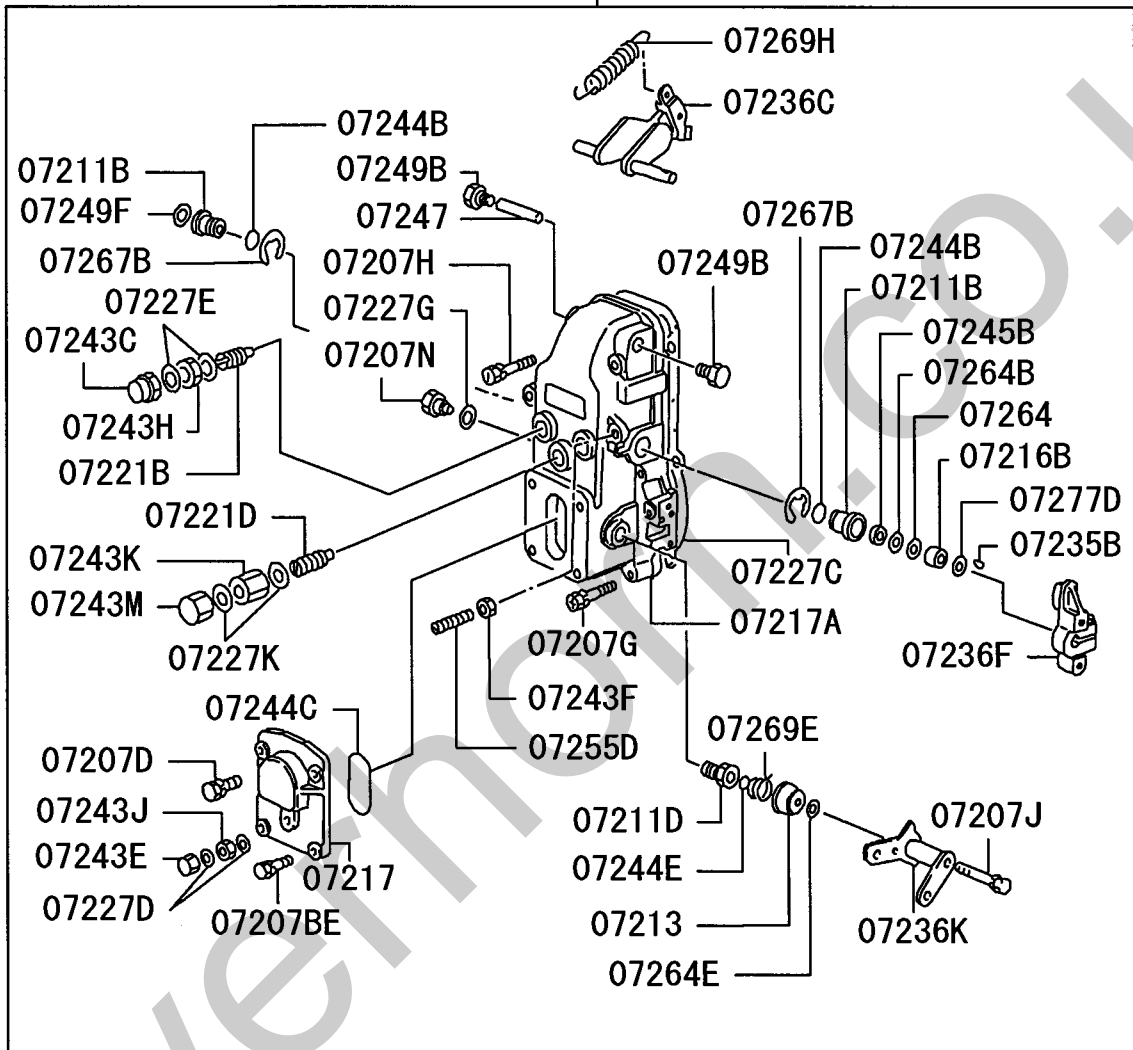

1-2/2
6D22-T

07040A

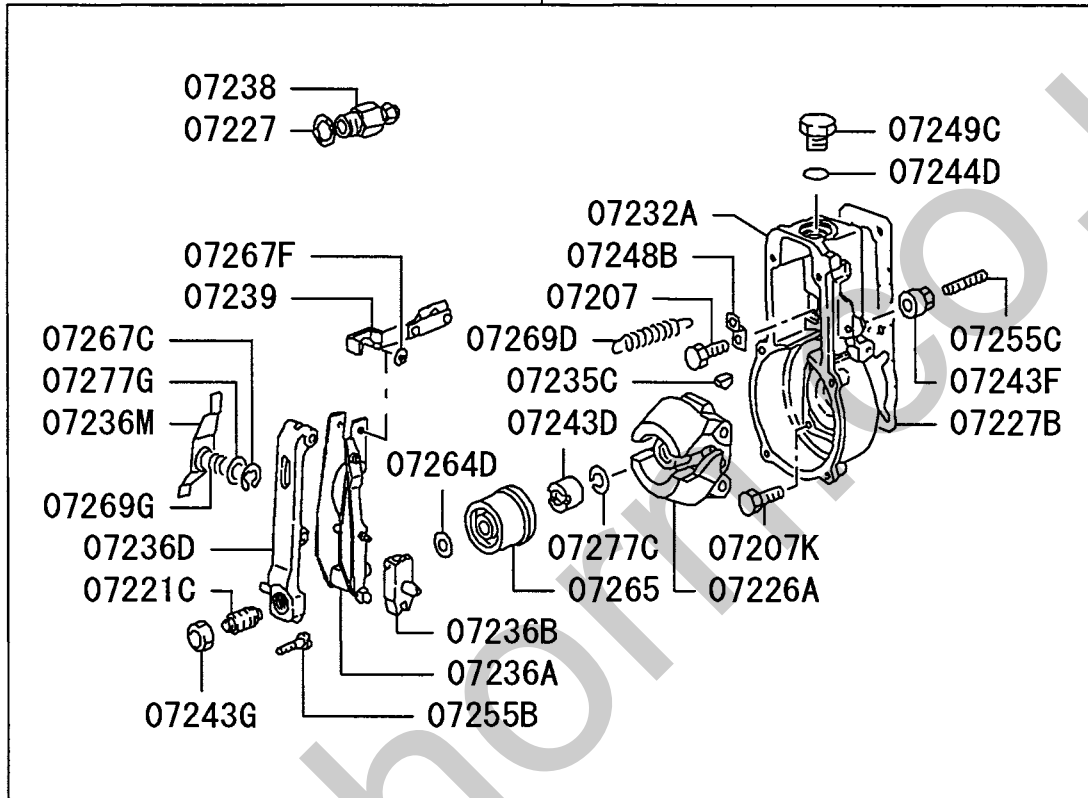

2-1/2
6D24-T

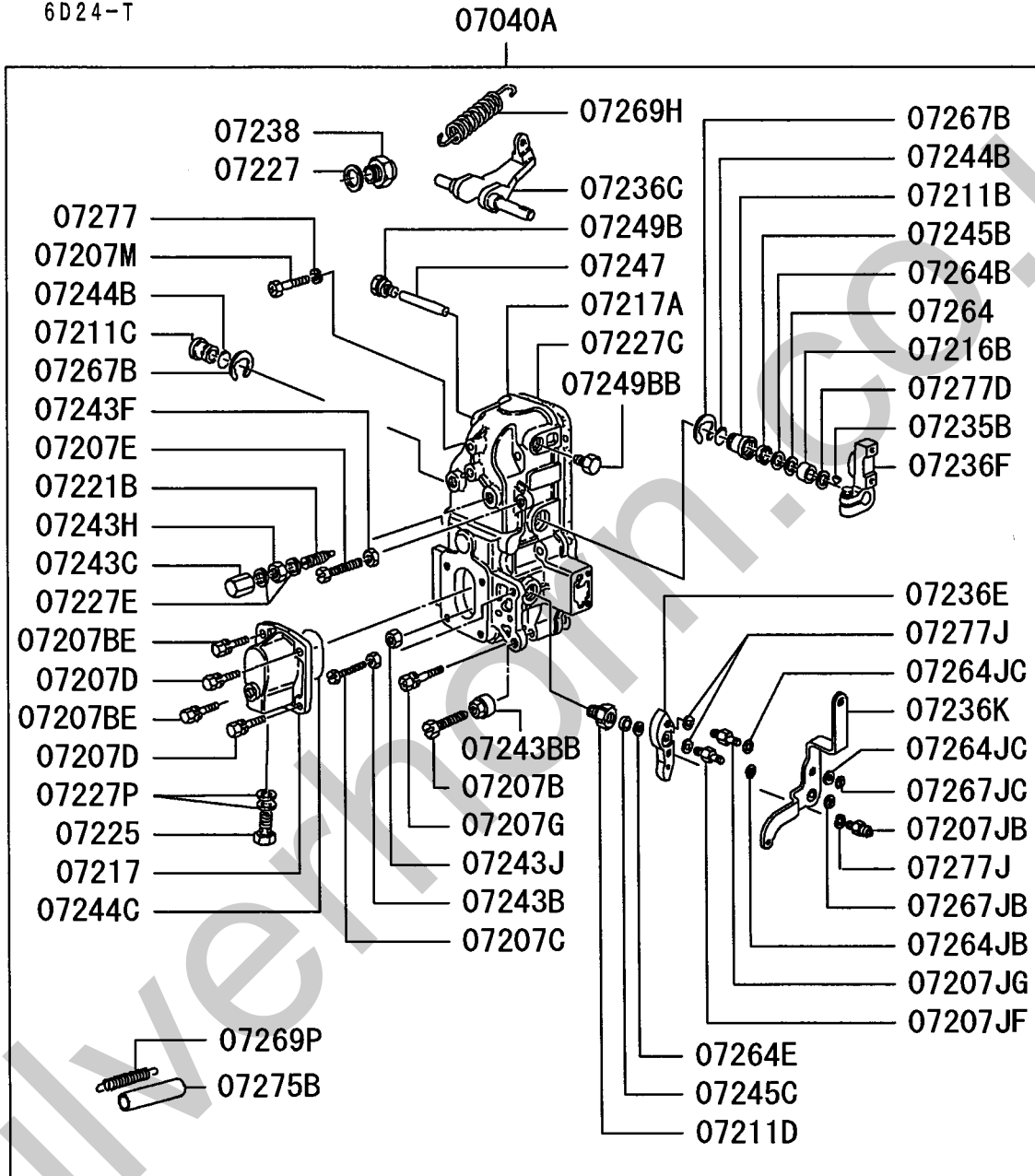

2-2/2
6D24-T

07040A

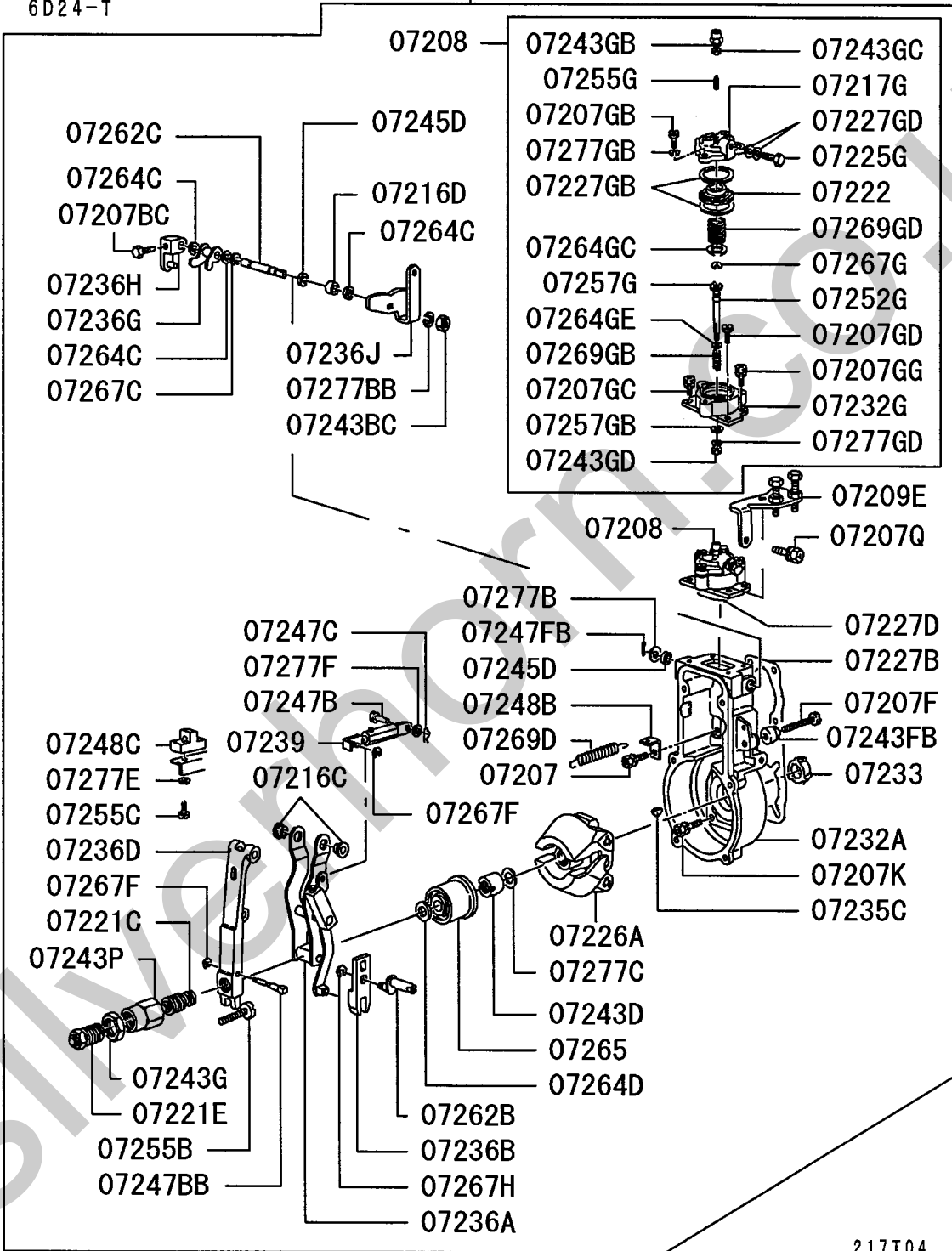

217T04

ガバナ
13-160 GOVERNOR

04 6D240 CTJS04US1
03 6D240 CTJS04000
02 6D221 CTJS12131 COLD
01 6D221 CTJS12000 STD

-98-

見出番号 REF.-NO.	部品番号 PART NO.	代 替 R / P	案 記 順 号 S C E N E P O G	部品名称および記事・仕様記号 PART NAME & DESCRIPTION	型式・個数 MODEL & QTY						適用号機 APPLICABLE SERIAL NO.	管 区 M / R	新 規 V R D	
											FROM@			@UPTO
					0	1	2	3	4					
07040A	1054080410			GOVERNOR ASSY,INJECTION PUMP RSV	1	1						9006-1		
	1054877690			GOVERNOR ASSY,INJECTION PUMP RFD			1	1				9901-1		
07207	0201062040			BOLT,INJECTION PUMP GOVERNOR	1	1						9006-1		
	0201061840			BOLT,INJECTION PUMP GOVERNOR			4	4				9901-1		
07207B	1540106000			BOLT,INJECTION PUMP GOVERNOR 10X55			1	1				9901-1		
	1540107900			BOLT,INJECTION PUMP GOVERNOR 10X58				1	1			9901-1		
07207BC	1550060700			BOLT,INJECTION PUMP GOVERNOR			1	1				9901-1		
07207BE	0290206210			BOLT,INJECTION PUMP GOVERNOR	2	2						9006-1		
	0200061640			BOLT,INJECTION PUMP GOVERNOR			2	2				9901-1		
07207C	1556153500			BOLT,INJECTION PUMP GOVERNOR			1	1				9901-1		
07207D	0200061640			BOLT,INJECTION PUMP GOVERNOR	2	2						9006-1		
	0290206210			BOLT,INJECTION PUMP GOVERNOR			2	2				9901-1		
07207E	1540107300			BOLT,INJECTION PUMP GOVERNOR			1	1				9901-1		
07207F	1540130600			BOLT,INJECTION PUMP GOVERNOR			1	1				9901-1		
07207G	0201063640			BOLT,INJECTION PUMP GOVERNOR	4	4						9006-1		
	0201064540			BOLT,INJECTION PUMP GOVERNOR			5	5				9901-1		
07207GB	0290106310			BOLT,INJECTION PUMP GOVERNOR			3	3				9901-1		
07207GC	0201061640			BOLT,INJECTION PUMP GOVERNOR			2	2				9901-1		
07207GD	0290206260			BOLT,INJECTION PUMP GOVERNOR			1	1				9901-1		
07207GG	0201062040			BOLT,INJECTION PUMP GOVERNOR			1	1				9901-1		
07207H	0201065040			BOLT,INJECTION PUMP GOVERNOR	2	2						9006-1		
07207J	0200064540			BOLT,INJECTION PUMP GOVERNOR	1	1						9006-1		
07207JB	1543576320			BOLT,INJECTION PUMP GOVERNOR			1	1				9901-1		
07207JF	1543718300			BOLT,INJECTION PUMP GOVERNOR			1	1				9901-1		
07207JG	1543765800			BOLT,INJECTION PUMP GOVERNOR			1	1				9901-1		
07207K	0201062040			BOLT,INJECTION PUMP GOVERNOR	7	7						9006-1		
	0201062040			BOLT,INJECTION PUMP GOVERNOR			4	4				9901-1		
07207M	0290106850			BOLT,INJECTION PUMP GOVERNOR			2	2				9901-1		
07207N	1544012700			BOLT,INJECTION PUMP GOVERNOR	1	1						9006-1		
07207Q	0201061240			BOLT,INJECTION PUMP GOVERNOR			1	1				9901-1		
07208	1544225420			BOOST COMPENSATOR,INJECTION PUMP GOVERNO			1	1				9901-1		
07209E	1543762220			BRACKET,INJECTION PUMP GOVERNOR			1	1				9901-1		
07211B	1542041900			BUSHING,INJECTION PUMP GOVERNOR	2	2						9006-1		
	1542005501			BUSHING,INJECTION PUMP GOVERNOR			1	1				9901-1		
07211C	1542043500			BUSHING,INJECTION PUMP GOVERNOR			1	1				9901-1		
07211D	1543210400			BUSHING,INJECTION PUMP GOVERNOR	1	1						9006-1		
	1543212000			BUSHING,INJECTION PUMP GOVERNOR			1	1				9901-1		
07213	1543220100			CAP,INJECTION PUMP GOVERNOR	1	1						9006-1		
07216B	1542062800			COLLAR,INJECTION PUMP GOVERNOR	1	1						9006-1		
	1542062300			COLLAR,INJECTION PUMP GOVERNOR			1	1				9901-1		
07216C	1542371300			COLLAR,INJECTION PUMP GOVERNOR			2	2				9901-1		
07216D	1542065400			COLLAR,INJECTION PUMP GOVERNOR			1	1				9901-1		
07217	1540631400			COVER,INJECTION PUMP GOVERNOR	1	1						9006-1		
	1540636121			COVER,INJECTION PUMP GOVERNOR			1	1				9901-1		
07217A	1545003320			COVER ASSY,INJECTION PUMP GOVERNOR	1	1						9006-1		
	1545166520			COVER ASSY,INJECTION PUMP GOVERNOR			1	1				9901-1		

ガバナ
13-160 GOVERNOR

04 6D240 CTJS04US1
03 6D240 CTJS04000
02 6D221 CTJS12131 COLD
01 6D221 CTJS12000 STD

-99-

見出番号 REF.-NO.	部品番号 PART NO.	代 替 順 号 S C E N E Q G	部品名称および記事・仕様記号 PART NAME & DESCRIPTION	型式・個数 MODEL & QTY				適用号機 APPLICABLE SERIAL NO. FROM@-@UPTO	管 区 M / R	新 規 V R D
				0	1	2	3			
07217G	1544045100		COVER,INJECTION PUMP GOVERNOR			1	1			9901-1
07221B	1542420620		DAMPER,INJECTION PUMP GOVERNOR	1	1					9006-1
	1540507720		DAMPER,INJECTION PUMP GOVERNOR			1	1			9901-1
07221C	1541770220		DAMPER,INJECTION PUMP GOVERNOR	1	1					9006-1
	1541892820		DAMPER,INJECTION PUMP GOVERNOR			1	1			9901-1
07221D	1541581020		DAMPER,INJECTION PUMP GOVERNOR	1	1					9006-1
07221E	1541885220		DAMPER,INJECTION PUMP GOVERNOR			1	1			9901-1
07222	1544009320		DIAPHRAGM,INJECTION PUMP GOVERNOR			1	1			9901-1
07225	1535564800		EYEBOLT,INJECTION PUMP GOVERNOR			1	1			9901-1
07225G	0297310180		EYEBOLT,INJECTION PUMP GOVERNOR			1	1			9901-1
07226A	1541010020		FLYWEIGHT ASSY,INJECTION PUMP GOVERNOR	1	1					9006-1
	1541009220		FLYWEIGHT ASSY,INJECTION PUMP GOVERNOR			1	1			9901-1
07227	0265243040		GASKET,INJECTION PUMP GOVERNOR	1	1	1	1			9006-1
07227B	1543508700		GASKET,INJECTION PUMP GOVERNOR	1	1					9006-1
	1543715600		GASKET,INJECTION PUMP GOVERNOR			1	1			9901-1
07227C	1543507800		GASKET,INJECTION PUMP GOVERNOR	1	1					9006-1
	1543900200		GASKET,INJECTION PUMP GOVERNOR			1	1			9901-1
07227D	0265061040		GASKET,INJECTION PUMP GOVERNOR	2	2					9006-1
	1543582500		GASKET,INJECTION PUMP GOVERNOR			1	1			9901-1
07227E	0265162040		GASKET,INJECTION PUMP GOVERNOR	2	2					9006-1
	0265121540		GASKET,INJECTION PUMP GOVERNOR			2	2			9901-1
07227G	0293310240		GASKET,INJECTION PUMP GOVERNOR	1	1					9006-1
07227GB	1544132600		GASKET,INJECTION PUMP GOVERNOR			2	2			9901-1
07227GD	0265101340		GASKET,INJECTION PUMP GOVERNOR			2	2			9901-1
07227K	0265121540		GASKET,INJECTION PUMP GOVERNOR	2	2					9006-1
07227P	0265121840		GASKET,INJECTION PUMP GOVERNOR			2	2			9901-1
07232A	1540004700		HOUSING ASSY,INJECTION PUMP GOVERNOR	1	1					9006-1
	1540041022		HOUSING ASSY,INJECTION PUMP GOVERNOR			1	1			9901-1
07232G	1544086220		HOUSING,INJECTION PUMP GOVERNOR			1	1			9901-1
07233	1554125200		IMPELLER,INJECTION PUMP GOVERNOR			1	1			9901-1
07235B	0258031310		KEY,INJECTION PUMP GOVERNOR	1	1	1	1			9006-1
07235C	0258031610		KEY,INJECTION PUMP GOVERNOR	1	1					9006-1
	0258031610		KEY,INJECTION PUMP GOVERNOR			1	1			9901-1
	0258031310		KEY,INJECTION PUMP GOVERNOR			1	1			9901-1
07236A	1542114320		LEVER ASSY,INJECTION PUMP GOVERNOR	1	1					9006-1
	1542161920		LEVER ASSY,INJECTION PUMP GOVERNOR			1	1			9901-1
07236B	1543265120		LEVER,INJECTION PUMP GOVERNOR	1	1					9006-1
	1543260300		LEVER,INJECTION PUMP GOVERNOR			1	1			9901-1
07236C	1542000120		LEVER,INJECTION PUMP GOVERNOR	1	1					9006-1
	1542005401		LEVER,INJECTION PUMP GOVERNOR			1	1			9901-1
07236D	1542363220		LEVER,INJECTION PUMP GOVERNOR	1	1					9006-1
	1542365200		LEVER,INJECTION PUMP GOVERNOR			1	1			9901-1
07236E	1543602800		LEVER,INJECTION PUMP GOVERNOR			1	1			9901-1
07236F	1543400120		LEVER,INJECTION PUMP GOVERNOR	1	1					9006-1
	1543401920		LEVER,INJECTION PUMP GOVERNOR			1	1			9901-1
07236G	1544081520		LEVER,INJECTION PUMP GOVERNOR			1	1			9901-1
07236H	1550031920		LEVER,INJECTION PUMP GOVERNOR			1	1			9901-1
07236J	1543833200		LEVER,INJECTION PUMP GOVERNOR			1	1			9901-1
07236K	1543643420		LEVER,INJECTION PUMP GOVERNOR	1	1					9006-1
	1543871920		LEVER,INJECTION PUMP GOVERNOR			1	1			9901-1

ガバナ
13-160 GOVERNOR

04 6D240 CTJS04US1
03 6D240 CTJS04000
02 6D221 CTJS12131 COLD
01 6D221 CTJS12000 STD

-100-

見出番号 REF.-NO.	部品番号 PART NO.	代 替 R / P	変 更 順 号 S C E N E Q G	部品名称および記事・仕様記号 PART NAME & DESCRIPTION	型式・個数 MODEL & QTY						適用号機 APPLICABLE SERIAL NO. FROM@-@UPTO	管 区 M / R	新 規 V R D
					0	1	2	3	4				
07236M	1542107420			LEVER,INJECTION PUMP GOVERNOR	1	1					9006-1		
07238	1530212220			LIMITER,INJECTION PUMP GOVERNOR	1	1					9006-1		
	1554041700			LIMITER,INJECTION PUMP GOVERNOR					1	1	9901-1		
07239	1542302920			LINK,INJECTION PUMP GOVERNOR	1	1					9006-1		
	1542348520			LINK,INJECTION PUMP GOVERNOR					1	1	9901-1		
07243B	0130206040			NUT,INJECTION PUMP GOVERNOR					1	1	9901-1		
07243BB	1540112200			NUT,INJECTION PUMP GOVERNOR					1	1	9901-1		
07243BC	0130208040			NUT,INJECTION PUMP GOVERNOR					1	1	9901-1		
07243C	1541591100			NUT,INJECTION PUMP GOVERNOR	1	1					9006-1		
	1541591200			NUT,INJECTION PUMP GOVERNOR					1	1	9901-1		
07243D	0292312030			NUT,INJECTION PUMP GOVERNOR	1	1					9006-1		
	1392120000			NUT,INJECTION PUMP GOVERNOR					1	1	9901-1		
07243E	1540351600			NUT,INJECTION PUMP GOVERNOR	1	1					9006-1		
07243F	1540110100			NUT,INJECTION PUMP GOVERNOR	2	2					9006-1		
	0130208040			NUT,INJECTION PUMP GOVERNOR					1	1	9901-1		
07243FB	1540112300			NUT,INJECTION PUMP GOVERNOR					1	1	9901-1		
07243G	0292016010			NUT,INJECTION PUMP GOVERNOR	1	1					9006-1		
	1392180100			NUT,INJECTION PUMP GOVERNOR					1	1	9901-1		
07243GB	1544067800			NUT,INJECTION PUMP GOVERNOR					1	1	9901-1		
07243GC	0230406040			NUT,INJECTION PUMP GOVERNOR					1	1	9901-1		
07243GD	0130305240			NUT,INJECTION PUMP GOVERNOR					1	1	9901-1		
07243H	0292016150			NUT,INJECTION PUMP GOVERNOR	1	1					9006-1		
	0292012130			NUT,INJECTION PUMP GOVERNOR					1	1	9901-1		
07243J	0292406010			NUT,INJECTION PUMP GOVERNOR	1	1					9006-1		
	0292010160			NUT,INJECTION PUMP GOVERNOR					1	1	9901-1		
07243K	1540111700			NUT,INJECTION PUMP GOVERNOR	1	1					9006-1		
07243M	1541591200			NUT,INJECTION PUMP GOVERNOR	1	1					9006-1		
07243P	1392180700			NUT,INJECTION PUMP GOVERNOR					1	1	9901-1		
07244B	0296318020			O-RING,INJECTION PUMP GOVERNOR	2	2					9006-1		
	1397000000			O-RING,INJECTION PUMP GOVERNOR					2	2	9901-1		
07244C	0296352020			O-RING,INJECTION PUMP GOVERNOR	1	1					9006-1		
	1397000100			O-RING,INJECTION PUMP GOVERNOR					1	1	9901-1		
07244D	0296325070			O-RING,INJECTION PUMP GOVERNOR	1	1					9006-1		
07244E	0296310030			O-RING,INJECTION PUMP GOVERNOR	1	1					9006-1		
07245B	1396110000			OIL SEAL,INJECTION PUMP GOVERNOR	1	1					9006-1		
	1396100101			OIL SEAL,INJECTION PUMP GOVERNOR					1	1	9901-1		
07245C	0296210080			OIL SEAL,INJECTION PUMP GOVERNOR					1	1	9901-1		
07245D	0296208050			OIL SEAL,INJECTION PUMP GOVERNOR					2	2	9901-1		
07247	1542370100			PIN,INJECTION PUMP GOVERNOR	1	1					9006-1		
	1542371200			PIN,INJECTION PUMP GOVERNOR					1	1	9901-1		
07247B	1542314900			PIN,INJECTION PUMP GOVERNOR					1	1	9901-1		
07247BB	1542380201			PIN,INJECTION PUMP GOVERNOR					1	1	9901-1		
07247C	1554023800			PIN,INJECTION PUMP GOVERNOR					1	1	9901-1		
				SNAP									
07247FB	0255201210			PIN,INJECTION PUMP GOVERNOR					1	1	9901-1		
				SPLIT									
07248B	1543506000			PLATE,INJECTION PUMP GOVERNOR	1	1	1	1			9006-1		
07248C	1542321220			PLATE,INJECTION PUMP GOVERNOR					1	1	9901-1		
07249B	1540360300			PLUG,INJECTION PUMP GOVERNOR	2	2					9006-1		
	1540361800			PLUG,INJECTION PUMP GOVERNOR					1	1	9901-1		

ガバナ
13-160 GOVERNOR

04 6D240 CTJS04US1
03 6D240 CTJS04000
02 6D221 CTJS12131 COLD
01 6D221 CTJS12000 STD

-101-

見出番号 REF.-NO.	部品番号 PART NO.	代 替 順 号 S C E N E P P Q G	部品名称および記事・仕様記号 PART NAME & DESCRIPTION	型式・個数 MODEL & QTY						適用号機 APPLICABLE SERIAL NO.	管 区 M / R	新 規 V R D	
				0	1	2	3	0	4				FROM@
													FROM@
07249BB	1540361900		PLUG,INJECTION PUMP GOVERNOR				1	1			9901-1		
07249C	1540072900		PLUG,INJECTION PUMP GOVERNOR	1	1						9006-1		
07249F	0291417010		PLUG,INJECTION PUMP GOVERNOR	1	1						9006-1		
07252G	1544005800		PUSH ROD,INJECTION PUMP GOVERNOR				1	1			9901-1		
07255B	1540312400		SCREW,INJECTION PUMP GOVERNOR	1	1						9006-1		
	1540313401		SCREW,INJECTION PUMP GOVERNOR				1	1			9901-1		
07255C	1540101100		SCREW,INJECTION PUMP GOVERNOR	1	1						9006-1		
	0105351040		SCREW,INJECTION PUMP GOVERNOR				1	1			9901-1		
07255D	1540100100		SCREW,INJECTION PUMP GOVERNOR	1	1						9006-1		
07255G	1544045300		SCREW,INJECTION PUMP GOVERNOR				1	1			9901-1		
07257G	1534000900		SEAT,INJECTION PUMP GOVERNOR				1	1			9901-1		
07257GB	1534000800		SEAT,INJECTION PUMP GOVERNOR				1	1			9901-1		
07262B	1543244100		SHAFT,INJECTION PUMP GOVERNOR				1	1			9901-1		
07262C	1550043301		SHAFT,INJECTION PUMP GOVERNOR				1	1			9901-1		
07264	0293111090		SHIM,INJECTION PUMP GOVERNOR	AR	AR						9006-1		
	1394110200		T=0.3 SHIM,INJECTION PUMP GOVERNOR						CC	CC	9901-1		
	1394110300		T=0.10 SHIM,INJECTION PUMP GOVERNOR						CC	CC	9901-1		
	1394110400		T=0.20 SHIM,INJECTION PUMP GOVERNOR						CC	CC	9901-1		
	1394110400		T=0.30 SHIM,INJECTION PUMP GOVERNOR						CC	CC	9901-1		
07264B	1394110000		SHIM,INJECTION PUMP GOVERNOR	1	1						9006-1		
	1394110100		SHIM,INJECTION PUMP GOVERNOR				1	1			9901-1		
07264C	0293108050		SHIM,INJECTION PUMP GOVERNOR						CC	CC	9901-1		
	1394081400		SHIM,INJECTION PUMP GOVERNOR						CC	CC	9901-1		
	1394081500		SHIM,INJECTION PUMP GOVERNOR						CC	CC	9901-1		
	0293108040		SHIM,INJECTION PUMP GOVERNOR						CC	CC	9901-1		
	0293110010		T=0.20 SHIM,INJECTION PUMP GOVERNOR	CC	CC						9006-1		
	0293110180		T=0.20 SHIM,INJECTION PUMP GOVERNOR	CC	CC						9006-1		
	0293110190		T=0.30 SHIM,INJECTION PUMP GOVERNOR	CC	CC						9006-1		
	1394100000		T=0.40 SHIM,INJECTION PUMP GOVERNOR	CC	CC						9006-1		
	0293110210		T=0.50 SHIM,INJECTION PUMP GOVERNOR	CC	CC						9006-1		
	1394100100		T=1.00 SHIM,INJECTION PUMP GOVERNOR	CC	CC						9006-1		
	0293110010		T=1.50 SHIM,INJECTION PUMP GOVERNOR						CC	CC	9901-1		
	0293110180		SHIM,INJECTION PUMP GOVERNOR						CC	CC	9901-1		
	0293110190		T=0.30 SHIM,INJECTION PUMP GOVERNOR						CC	CC	9901-1		
	1394100000		T=0.40 SHIM,INJECTION PUMP GOVERNOR						CC	CC	9901-1		
	1394100000		T=0.50 SHIM,INJECTION PUMP GOVERNOR						CC	CC	9901-1		

ガバナ
13-160 GOVERNOR

04 6D240 CTJS04US1
03 6D240 CTJS04000
02 6D221 CTJS12131 COLD
01 6D221 CTJS12000 STD

-102-

見出番号 REF.-NO.	部品番号 PART NO.	代 替 順 号 S C E N E P O G	部品名称および記事・仕様記号 PART NAME & DESCRIPTION	型式・個数 MODEL & QTY				適用号機 APPLICABLE SERIAL NO. FROM@ - @UPTO	管 区 M / R	新 規 V R D
				0	1	2	3			
	0293110210		SHIM,INJECTION PUMP GOVERNOR T=1.00			CC	CC		9901.1	
	1394100100		SHIM,INJECTION PUMP GOVERNOR T=1.50			CC	CC		9901.1	
	1394103000		SHIM,INJECTION PUMP GOVERNOR T=2.00			CC	CC		9901.1	
	1394103100		SHIM,INJECTION PUMP GOVERNOR T=3.00			CC	CC		9901.1	
	1394103200		SHIM,INJECTION PUMP GOVERNOR T=4.00			CC	CC		9901.1	
07264E	0293110520		SHIM,INJECTION PUMP GOVERNOR T=0.20			CC	CC		9006.1	
	0293110530		SHIM,INJECTION PUMP GOVERNOR T=0.25			CC	CC		9006.1	
	0293110540		SHIM,INJECTION PUMP GOVERNOR T=0.30			CC	CC		9006.1	
	0239110550		SHIM,INJECTION PUMP GOVERNOR T=0.35			CC	CC		9006.1	
	0293110560		SHIM,INJECTION PUMP GOVERNOR T=0.40			CC	CC		9006.1	
	0293110570		SHIM,INJECTION PUMP GOVERNOR T=0.50			CC	CC		9006.1	
	0293110650		SHIM,INJECTION PUMP GOVERNOR T=0.20				CC	CC	9901.1	
	0293110660		SHIM,INJECTION PUMP GOVERNOR T=0.25				CC	CC	9901.1	
	0293110670		SHIM,INJECTION PUMP GOVERNOR T=0.30				CC	CC	9901.1	
	0293110680		SHIM,INJECTION PUMP GOVERNOR T=0.35				CC	CC	9901.1	
	0293110690		SHIM,INJECTION PUMP GOVERNOR T=0.40				CC	CC	9901.1	
	0293110700		SHIM,INJECTION PUMP GOVERNOR T=0.50				CC	CC	9901.1	
	1394102700		SHIM,INJECTION PUMP GOVERNOR T=0.60				CC	CC	9901.1	
	1394101400		SHIM,INJECTION PUMP GOVERNOR T=0.70				CC	CC	9901.1	
	1394101600		SHIM,INJECTION PUMP GOVERNOR T=0.80				CC	CC	9901.1	
	1394101500		SHIM,INJECTION PUMP GOVERNOR T=0.90				CC	CC	9901.1	
	0293110640		SHIM,INJECTION PUMP GOVERNOR T=0.95				CC	CC	9901.1	
07264GC	0293120210		SHIM,INJECTION PUMP GOVERNOR T=0.20				CC	CC	9901.1	
	0293120180		SHIM,INJECTION PUMP GOVERNOR T=0.50				CC	CC	9901.1	
07264GE	1543553900		SHIM,INJECTION PUMP GOVERNOR T=0.1				CC	CC	9901.1	

ガバナ
13-160 GOVERNOR

04 6D240 CTJS04US1
03 6D240 CTJS04000
02 6D221 CTJS12131 COLD
01 6D221 CTJS12000 STD

-103-

見出番号 REF.-NO.	部品番号 PART NO.	代 替 順 号 S C E N E P O G	部品名称および記事・仕様記号 PART NAME & DESCRIPTION	型式・個数 MODEL & QTY				適用号機 APPLICABLE SERIAL NO. FROM @ - @ UPTO	管 区 M / R	新 規 V R D
				0	1	2	3			
07264JB	1543554000		SHIM,INJECTION PUMP GOVERNOR T=0.2			CC	CC		9901-1	
	1543554100		SHIM,INJECTION PUMP GOVERNOR T=0.3			CC	CC		9901-1	
	0293108610		SHIM,INJECTION PUMP GOVERNOR T=0.1			CC	CC		9901-1	
	0293108620		SHIM,INJECTION PUMP GOVERNOR T=0.15			CC	CC		9901-1	
	0293108630		SHIM,INJECTION PUMP GOVERNOR T=0.2			CC	CC		9901-1	
	0293108650		SHIM,INJECTION PUMP GOVERNOR T=0.5			CC	CC		9901-1	
07264JC	0293106130		SHIM,INJECTION PUMP GOVERNOR			2	2		9901-1	
07265	1541232320		SLEEVE,INJECTION PUMP GOVERNOR	1	1	1	1		9006-1	
07267B	0160101640		SNAP RING,INJECTION PUMP GOVERNOR	2	2				9006-1	
07267C	1543543900		SNAP RING,INJECTION PUMP GOVERNOR			2	2		9901-1	
	0160100710		SNAP RING,INJECTION PUMP GOVERNOR	1	1				9006-1	
07267F	0160100740		SNAP RING,INJECTION PUMP GOVERNOR			1	1		9901-1	
	0160100540		SNAP RING,INJECTION PUMP GOVERNOR	1	1				9006-1	
	0160100540		SNAP RING,INJECTION PUMP GOVERNOR			2	2		9901-1	
07267G	0160100740		SNAP RING,INJECTION PUMP GOVERNOR			1	1		9901-1	
07267H	0160100840		SNAP RING,INJECTION PUMP GOVERNOR			1	1		9901-1	
07267JB	1592384200		SNAP RING,INJECTION PUMP GOVERNOR			1	1		9901-1	
07267JC	0160100640		SNAP RING,INJECTION PUMP GOVERNOR			1	1		9901-1	
07269D	1541540500		SPRING,INJECTION PUMP GOVERNOR	1	1				9006-1	
07269E	1541540701		SPRING,INJECTION PUMP GOVERNOR			1	1		9901-1	
	1543277300		SPRING,INJECTION PUMP GOVERNOR	1	1				9006-1	
07269G	1543271900		SPRING,INJECTION PUMP GOVERNOR	1	1				9006-1	
07269GB	1544112200		SPRING,INJECTION PUMP GOVERNOR			1	1		9901-1	
07269GD	1544020600		SPRING,INJECTION PUMP GOVERNOR			1	1		9901-1	
07269H	1541500400		SPRING,INJECTION PUMP GOVERNOR	1	1				9006-1	
07269P	1541509000		SPRING,INJECTION PUMP GOVERNOR			1	1		9901-1	
	1543172000		SPRING,INJECTION PUMP GOVERNOR			1	1		9901-1	
07275B	1541561500		TUBE,INJECTION PUMP GOVERNOR			1	1		9901-1	
07277	0141106440		WASHER,INJECTION PUMP GOVERNOR			2	2		9901-1	
07277B	1393080900		SPRING,T=1.5 WASHER,INJECTION PUMP GOVERNOR T=1.00			1	1		9901-1	
	1393081000		WASHER,INJECTION PUMP GOVERNOR T=1.50			1	1		9901-1	
07277BB	F251508000		WASHER,INJECTION PUMP GOVERNOR SPRING,8			1	1		9901-1	
07277C	0293212020		WASHER,INJECTION PUMP GOVERNOR SPRING	1	1	1	1		9006-1	
07277D	1542060200		WASHER,INJECTION PUMP GOVERNOR	AR	AR				9006-1	
	1542062400		WASHER,INJECTION PUMP GOVERNOR T=1.0			AR	AR		9901-1	
07277E	0293205020		WASHER,INJECTION PUMP GOVERNOR			1	1		9901-1	
07277F	0293105170		WASHER,INJECTION PUMP GOVERNOR			1	1		9901-1	
07277G	0293108020		WASHER,INJECTION PUMP GOVERNOR	1	1				9006-1	

オートマチックタイマ
13-270 AUTOMATIC TIMER

-106-

SP TYPE
6D22-T

07030A

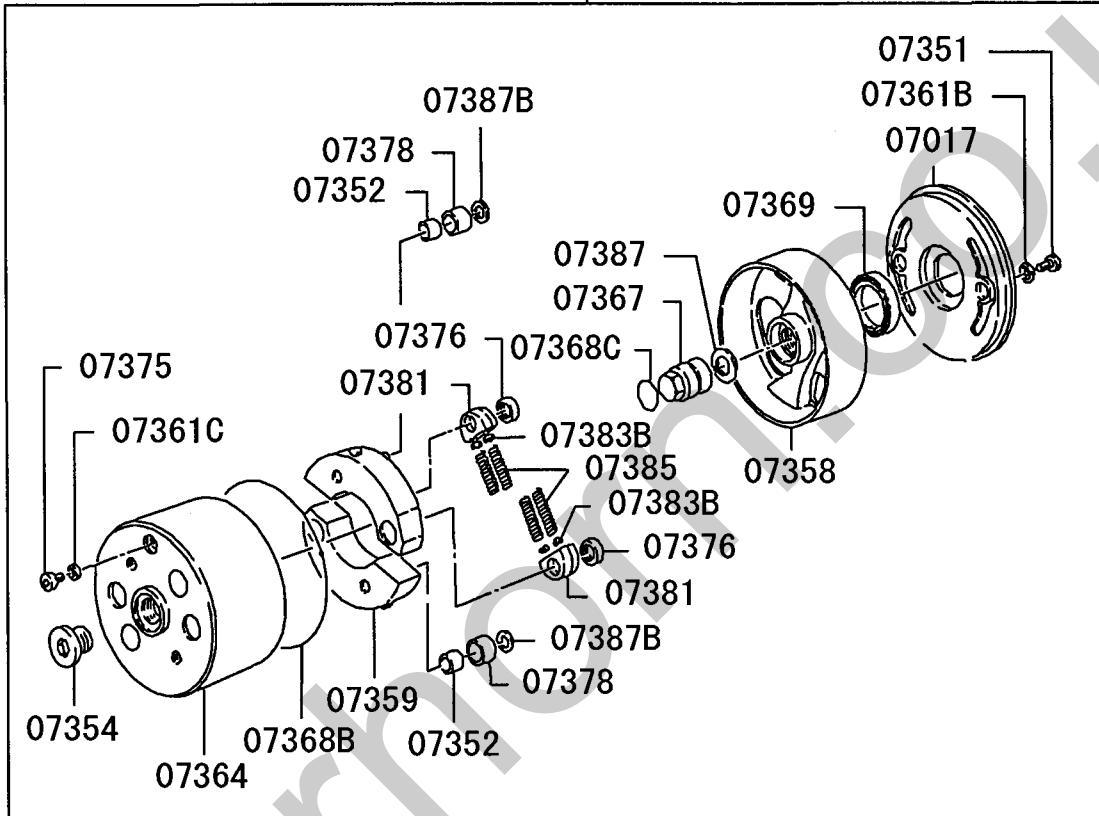

217T02

SPG TYPE
6D24-T

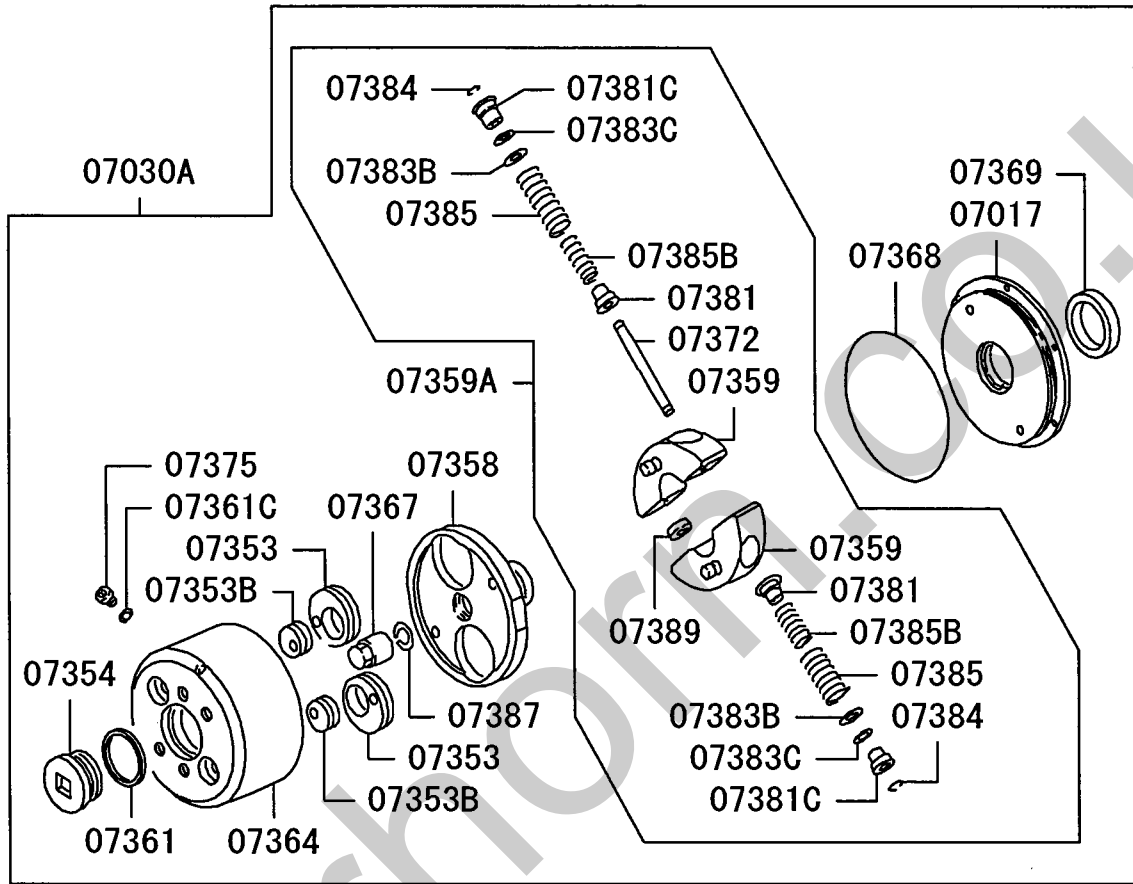

オートマチックタイマ
13-270 AUTOMATIC TIMER

04 6D240 CTJS04US1
03 6D240 CTJS04000
02 6D221 CTJS12131 COLD
01 6D221 CTJS12000 STD

-108-

見出番号 REF.-NO.	部品番号 PART NO.	代 替 R / P	変 更 順 号 S C E N E Q G	部品名称および記事・仕様記号 PART NAME & DESCRIPTION	型式・個数 MODEL & QTY						適用号機 APPLICABLE SERIAL NO. FROM@-@UPTO	管 区 M / R	新 規 V R D
					0	1	2	3	4				
07017	1563080600			COVER,INJECTION PUMP TIMER	1	1					9006-1		
	1568091620			COVER,INJECTION PUMP TIMER			1	1			9901-1		
07030A	1056361820			TIMER ASSY,INJECTION PUMP	1	1					9006-1		
	1056812520			TIMER ASSY,INJECTION PUMP			1	1			9901-1		
07351	1566334800			BOLT,INJECTION PUMP TIMER	2	2					9006-1		
07352	1563120000			BUSHING,INJECTION PUMP TIMER	2	2					9006-1		
07353	1567230300			CAM,INJECTION PUMP TIMER			2	2			9901-1		
07353B	1567230400			CAM,INJECTION PUMP TIMER			2	2			9901-1		
07354	1563140501			CAP,INJECTION PUMP TIMER	1	1					9006-1		
	1563140600			CAP,INJECTION PUMP TIMER			1	1			9901-1		
07358	1563230820			FLANGE,INJECTION PUMP TIMER	1	1					9006-1		
	1568016200			FLANGE,INJECTION PUMP TIMER			1	1			9901-1		
07359	1563057620			FLYWEIGHT,INJECTION PUMP TIMER	2	2					9006-1		
	1568020420			FLYWEIGHT,INJECTION PUMP TIMER			2	2			9901-1		
07359A	1568982820			FLYWEIGHT ASSY,INJECTION PUMP TIMER			1	1			9901-1		
07361	1563190200			GASKET,INJECTION PUMP TIMER			1	1			9901-1		
07361B	1563190100			GASKET,INJECTION PUMP TIMER	2	2					9006-1		
07361C	0293310190			GASKET,INJECTION PUMP TIMER	1	1	1	1			9006-1		
07364	1563001122			HOUSING,INJECTION PUMP TIMER	1	1					9006-1		
	1568003420			HOUSING,INJECTION PUMP TIMER			1	1			9901-1		
07367	1343250300			NUT,INJECTION PUMP TIMER	1	1					9006-1		
	1343250800			NUT,INJECTION PUMP TIMER			1	1			9901-1		
07368	1563150200			O-RING,INJECTION PUMP TIMER			1	1			9901-1		
07368B	1563150200			O-RING,INJECTION PUMP TIMER	1	1					9006-1		
07368C	0296328010			O-RING,INJECTION PUMP TIMER	1	1					9006-1		
07369	1563090000			OIL SEAL,INJECTION PUMP TIMER	1	1					9006-1		
	1396480300			OIL SEAL,INJECTION PUMP TIMER			1	1			9901-1		
07372	1568060900			PIN,INJECTION PUMP TIMER			2	2			9901-1		
07375	1563160000			PLUG,INJECTION PUMP TIMER	1	1	1	1			9006-1		
07376	1563170100			RETAINER,INJECTION PUMP TIMER	2	2					9006-1		
07378	1563130000			ROLLER,INJECTION PUMP TIMER	2	2					9006-1		
				D=23.90									
	1563130100			ROLLER,INJECTION PUMP TIMER	2	2					9006-1		
				D=24.00									
	1563130200			ROLLER,INJECTION PUMP TIMER	2	2					9006-1		
				D=24.10									
	1563130300			ROLLER,INJECTION PUMP TIMER	2	2					9006-1		
				D=24.20									
07381	1563100000			SEAT,INJECTION PUMP TIMER	2	2					9006-1		
	1568071100			SEAT,INJECTION PUMP TIMER			4	4			9901-1		
07381C	1568070900			SEAT,INJECTION PUMP TIMER			4	4			9901-1		
	1568070000			SEAT,INJECTION PUMP TIMER			8	8			9901-1		
07383B	1394080300			SHIM,INJECTION PUMP TIMER	CC	CC					9006-1		
				T=0.10									
	0293108520			SHIM,INJECTION PUMP TIMER	CC	CC					9006-1		
				T=0.20									
	1394080000			SHIM,INJECTION PUMP TIMER	CC	CC					9006-1		
				T=0.30									
	0293108530			SHIM,INJECTION PUMP TIMER	CC	CC					9006-1		
				T=0.40									

13-270 AUTOMATIC TIMER

オートマチックタイ

04 6D240 CTJS04US1
 03 6D240 CTJS04000
 02 6D221 CTJS12131 COLD
 01 6D221 CTJS12000 STD

-109-

見出番号 REF.-NO.	部品番号 PART NO.	代 替 R / P	変 更 順 号 S C E N E Q G	部品名称および記事・仕様記号 PART NAME & DESCRIPTION	型式・個数 MODEL & QTY						適用号機 APPLICABLE SERIAL NO.	管 区 M / R	新 規 V / R D	
					0	1	2	3	4		FROM@			@UPTO
	0293108540			SHIM,INJECTION PUMP TIMER T=0.50	CC	CC						9006・1		
	0293108550			SHIM,INJECTION PUMP TIMER T=0.60	CC	CC						9006・1		
	0293108560			SHIM,INJECTION PUMP TIMER T=0.70	CC	CC						9006・1		
	1394080100			SHIM,INJECTION PUMP TIMER T=0.80	CC	CC						9006・1		
	1394080200			SHIM,INJECTION PUMP TIMER T=0.90	CC	CC						9006・1		
	0293108680			SHIM,INJECTION PUMP TIMER T=1.00	CC	CC						9006・1		
	1394080500			SHIM,INJECTION PUMP TIMER T=1.50	CC	CC						9006・1		
	1394080600			SHIM,INJECTION PUMP TIMER T=2.00	CC	CC						9006・1		
	1567280800			SHIM,INJECTION PUMP TIMER T=0.10			CC	CC				9901・1		
	1567280900			SHIM,INJECTION PUMP TIMER T=0.30			CC	CC				9901・1		
	1567282000			SHIM,INJECTION PUMP TIMER T=0.40			CC	CC				9901・1		
	1567281000			SHIM,INJECTION PUMP TIMER T=0.50			CC	CC				9901・1		
	1567282100			SHIM,INJECTION PUMP TIMER T=0.70			CC	CC				9901・1		
	1567281100			SHIM,INJECTION PUMP TIMER T=1.00			CC	CC				9901・1		
07383C	1567281200			SHIM,INJECTION PUMP TIMER T=0.10			CC	CC				9901・1		
	1567281300			SHIM,INJECTION PUMP TIMER T=0.30			CC	CC				9901・1		
	1567282200			SHIM,INJECTION PUMP TIMER T=0.40			CC	CC				9901・1		
	1567281400			SHIM,INJECTION PUMP TIMER T=0.50			CC	CC				9901・1		
	1567282300			SHIM,INJECTION PUMP TIMER T=0.70			CC	CC				9901・1		
	1567281500			SHIM,INJECTION PUMP TIMER T=1.00			CC	CC				9901・1		
07384	1568090300			SNAP RING,INJECTION PUMP TIMER			4	4				9901・1		
07385	1563219700			SPRING,INJECTION PUMP TIMER	4	4						9006・1		
	1568966200			SPRING,INJECTION PUMP TIMER			1	1				9901・1		
	1568966300			SPRING,INJECTION PUMP TIMER			4	4				9901・1		
	1568976100			SPRING,INJECTION PUMP TIMER			4	4				9901・1		
07385B	1568941600			SPRING,INJECTION PUMP TIMER			4	4				9901・1		
07387	0293218020			WASHER,INJECTION PUMP TIMER	1	1						9006・1		
	1563220000			WASHER,INJECTION PUMP TIMER			1	1				9901・1		
07387B	0293012250			WASHER,INJECTION PUMP TIMER	2	2						9006・1		
07389	1568080500			SPACER,INJECTION PUMP TIMER			4	4				9901・1		

13-290 フューエル フィード ポンプ
FUEL FEED PUMP

-110-

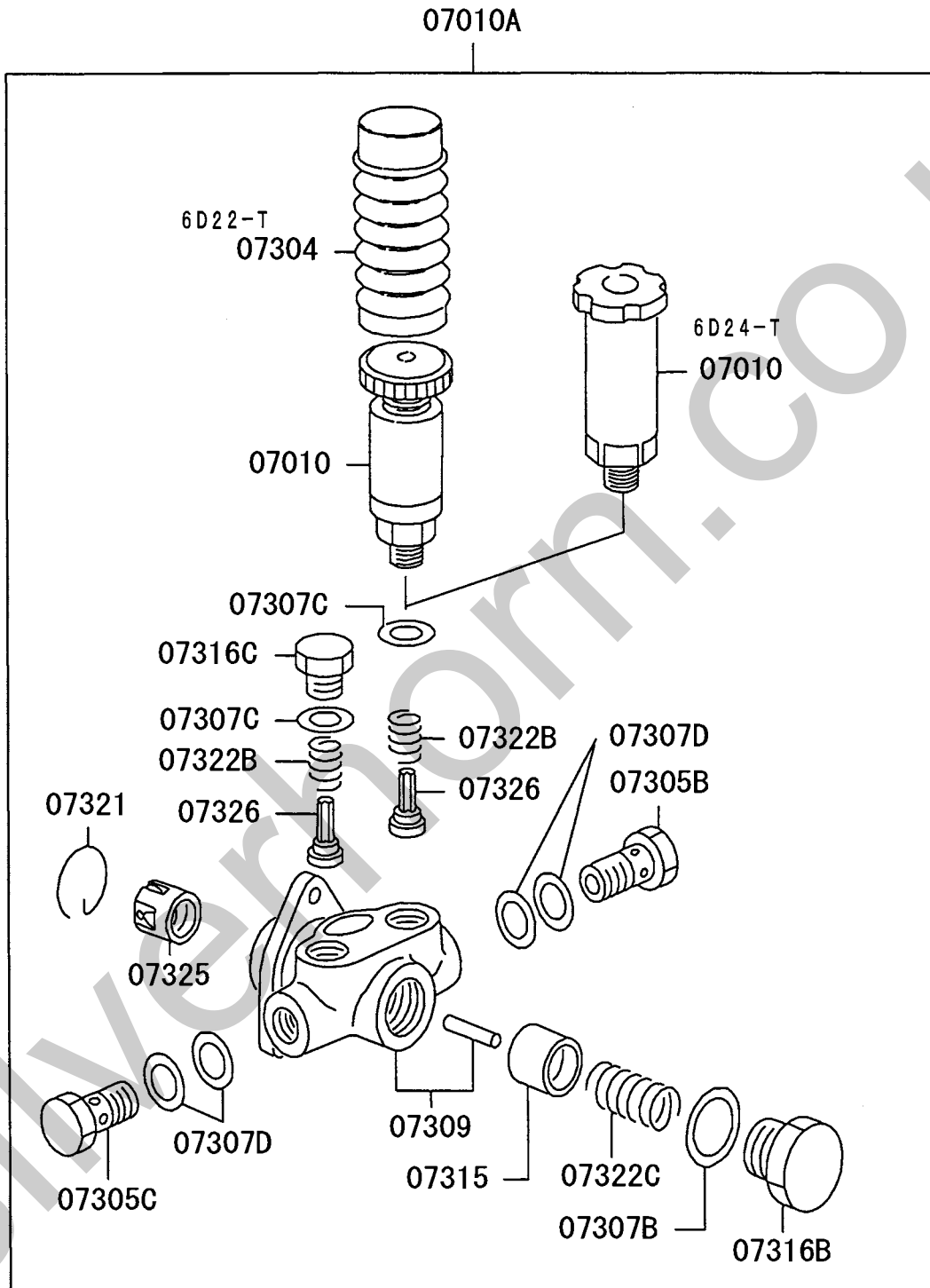

217T01

13 -290 FUEL FEED PUMP

燃料フィーディングポンプ

04 6D240 CTJS04US1
 03 6D240 CTJS04000
 02 6D221 CTJS12131 COLD
 01 6D221 CTJS12000 STD

-111-

見出番号 REF.-NO.	部品番号 PART NO.	代 替 R / P	変 更 順 号 S C E N A R I O	部品名称および記事・仕様記号 PART NAME & DESCRIPTION	型式・個数 MODEL & QTY						適用号機 APPLICABLE SERIAL NO. FROM @ - @UPTO	管 区 M / R	新 規 V R D
					0	1	2	3	4				
07010	1522002120			PUMP,INJECTION PUMP FUEL FEED	1	1					9006-1		
	1522005620			PUMP,INJECTION PUMP FUEL FEED				1	1		9901-1		
07010A	1052071210			PUMP ASSY,INJECTION PUMP FUEL FEED	1	1					9006-1		
	1052071200			PUMP ASSY,INJECTION PUMP FUEL FEED				1	1		9901-1		
07304	1523200100			COVER,INJECTION PUMP FUEL FEED PUMP	1	1					9006-1		
07305B	1523007120			EYEBOLT,INJECTION PUMP FUEL FEED PUMP	1	1					9006-1		
	1523007120			EYEBOLT,INJECTION PUMP FUEL FEED PUMP				1	1		9901-1		
07305C	0297314570			EYEBOLT,INJECTION PUMP FUEL FEED PUMP	1	1	1	1			9006-1		
07307B	0293326030			GASKET,INJECTION PUMP FUEL FEED PUMP	1	1	1	1			9006-1		
07307C	0293316030			GASKET,INJECTION PUMP FUEL FEED PUMP	2	2	2	2			9006-1		
07307D	0293414130			GASKET,INJECTION PUMP FUEL FEED PUMP	4	4	4	4			9006-1		
07309	1520004620			HOUSING,INJECTION PUMP FUEL FEED PUMP	1	1	1	1			9006-1		
07315	1521001120			PISTON,INJECTION PUMP FUEL FEED PUMP	1	1	1	1			9006-1		
07316B	1521050200			PLUG,INJECTION PUMP FUEL FEED PUMP	1	1					9006-1		
	1521051500			PLUG,INJECTION PUMP FUEL FEED PUMP				1	1		9901-1		
07316C	1521170400			PLUG,INJECTION PUMP FUEL FEED PUMP	1	1	1	1			9006-1		
07321	1521210200			SNAP RING,INJECTION PUMP FUEL FEED PUMP	1	1	1	1			9006-1		
07322B	1521160200			SPRING,INJECTION PUMP FUEL FEED PUMP	2	2	2	2			9006-1		
07322C	1521020400			SPRING,INJECTION PUMP FUEL FEED PUMP	1	1	1	1			9006-1		
07325	1521113221			TAPPET,INJECTION PUMP FUEL FEED PUMP	1	1	1	1			9006-1		
07326	1521150500			VALVE,INJECTION PUMP FUEL FEED PUMP	2	2					9006-1		
	1521150200			VALVE,INJECTION PUMP FUEL FEED PUMP				2	2		9901-1		

6D24-T

07020A

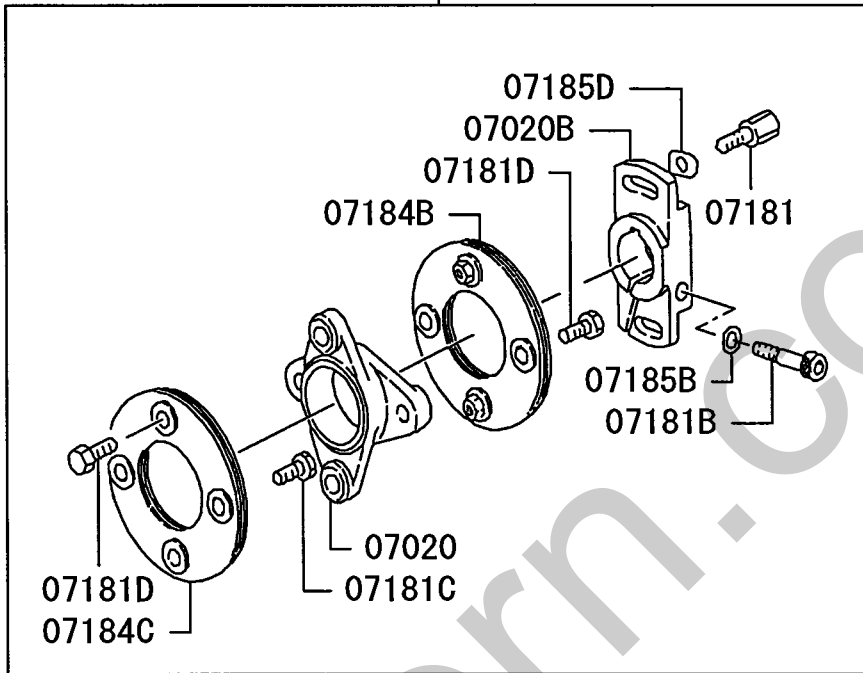

6D22-T

07020A

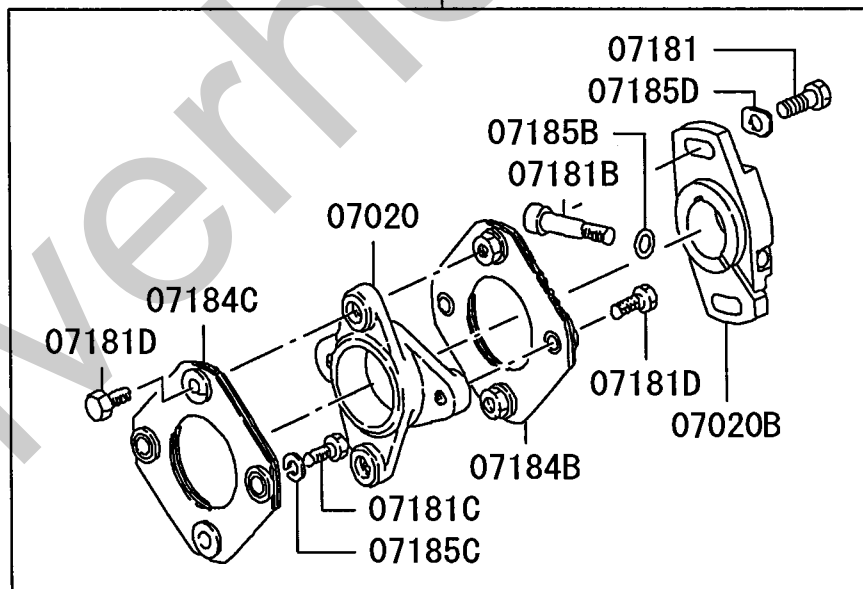

カップリング
13-320 COUPLING

04 6D240 CTJS04US1
03 6D240 CTJS04000
02 6D221 CTJS12131 COLD
01 6D221 CTJS12000 STD

-113-

見出番号 REF.-NO.	部品番号 PART NO.	代 替 R / P	変 更 順 号 S C E N E Q G	部品名称および記事・仕様記号 PART NAME & DESCRIPTION	型式・個数 MODEL & QTY					適用号機 APPLICABLE SERIAL NO. FROM @ - @UPTO	管 区 M / R	新 規 V / R D	
					0	1	2	3	4				
07020	1566095300			COUPLING,INJECTION PUMP	1	1	1	1			9006-1		
07020A	1056620710			COUPLING ASSY,INJECTION PUMP	1	1					9006-1		
	1056630910			COUPLING ASSY,INJECTION PUMP			1	1			9901-1		
07020B	1566307700			COUPLING,INJECTION PUMP	1	1					9006-1		
	1566311900			COUPLING,INJECTION PUMP			1	1			9901-1		
07181	1566333200			BOLT,INJECTION PUMP COUPLING	2	2					9006-1		
	1566332900			BOLT,INJECTION PUMP COUPLING			2	2			9901-1		
07181B	1566037200			BOLT,INJECTION PUMP COUPLING	1	1	1	1			9006-1		
07181C	1566332100			BOLT,INJECTION PUMP COUPLING	2	2					9006-1		
	1566338000			BOLT,INJECTION PUMP COUPLING			2	2			9901-1		
07181D	1566332100			BOLT,INJECTION PUMP COUPLING	4	4	4	4			9006-1		
07184B	1566054520	3		PLATE,INJECTION PUMP COUPLING	1	1					9006-1		
	(1566055520)												
	1566056520			PLATE,INJECTION PUMP COUPLING			1	1			9901-1		
07184C	1566054420			PLATE,INJECTION PUMP COUPLING	1	1					9006-1		
	1566055320			PLATE,INJECTION PUMP COUPLING			1	1			9901-1		
07185B	1566152600			WASHER,INJECTION PUMP COUPLING	1	1	1	1			9006-1		
07185C	0141110440			WASHER,INJECTION PUMP COUPLING	2	2					9006-1		
				SPRING									
07185D	1566152800			WASHER,INJECTION PUMP COUPLING	2	2	2	2			9006-1		

インジェクションパイプ & ノズル
 13-410 INJECTION PIPE & NOZZLE

-114-

INJECTION PIPE

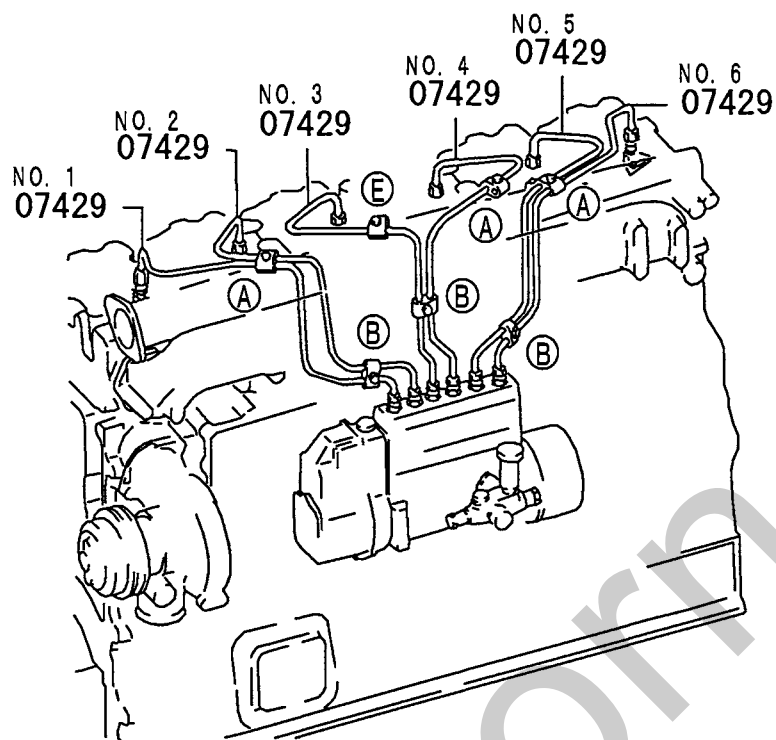

- (A) 07499C
- 07498F
- 07498F
- (B) 07499C
- 07498F
- 07498G
- (E) 07499C
- 07498F
- 07498F
- 07499B
- 07495

217T01

INJECTION PIPE
(-9304-2)

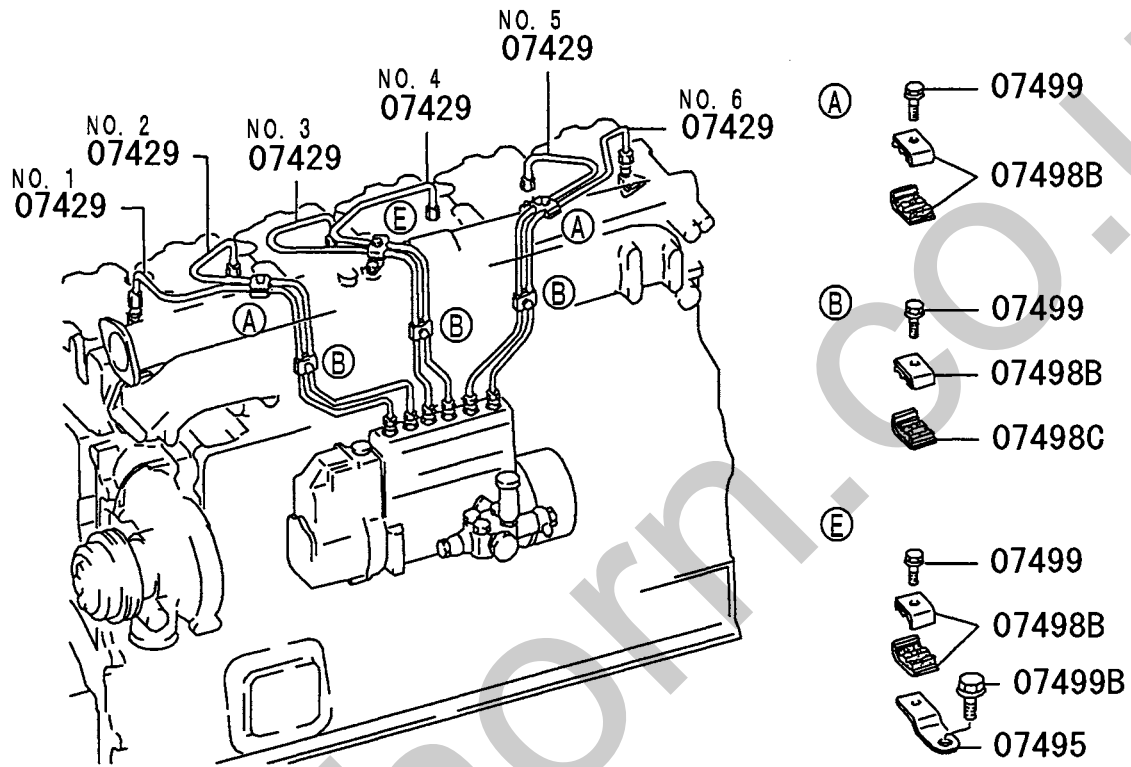

インジェクションパイプ & ノズル
13-410 INJECTION PIPE & NOZZLE

-116-

INJECTION NOZZLE
6D22-T

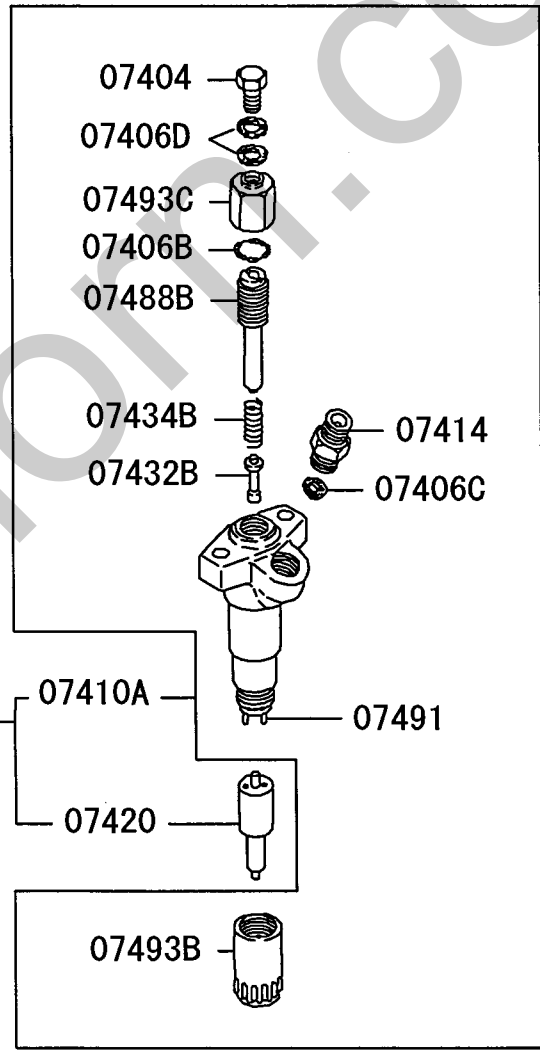
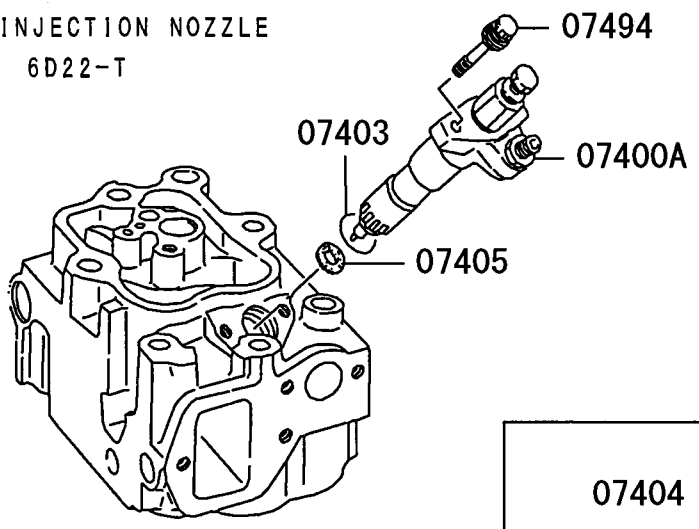

217T03

INJECTION NOZZLE
6D24-T

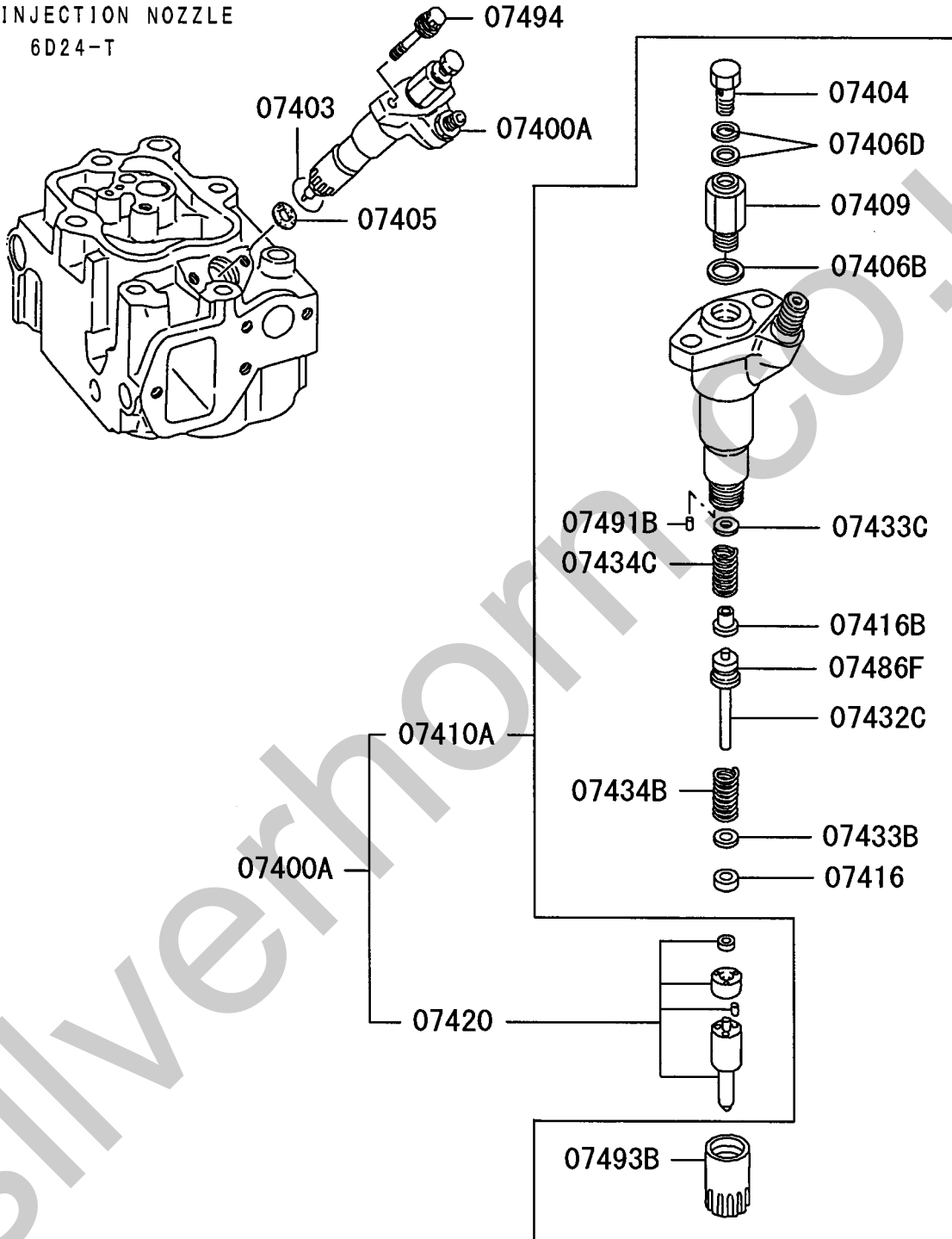

13-410 INJECTION PIPE & NOZZLE

04 6D240 CTJS04US1
 03 6D240 CTJS04000
 02 6D221 CTJS12131 COLD
 01 6D221 CTJS12000 STD

-118-

見出番号 REF.-NO.	部品番号 PART NO.	代 替 R / P 記 順 号 S C E N O G	部品名称および記事・仕様記号 PART NAME & DESCRIPTION	型式・個数 MODEL & QTY						適用号機 APPLICABLE SERIAL NO. FROM@-@UPTO	管 区 M / R	新 規 V R D
				0	1	2	3	4				
07400A	1051006210		NOZZLE & HOLDER ASSY,FUEL INJECTION ZEXEL	6	6					9006-1		
	1051107550		NOZZLE & HOLDER ASSY,FUEL INJECTION ZEXEL			6	6			9901-1		
07403	3096102200		DUST SEAL,FUEL INJECTION NOZZLE HOLDER	6	6	6	6			9006-1		
07404	1506131700		EYEBOLT,FUEL INJECTION NOZZLE	6	6	6	6			9006-1		
07405	3096102300		GASKET,FUEL INJECTION NOZZLE	6	6	6	6			9006-1		
07406B	0293310240		GASKET,FUEL INJECTION NOZZLE INR	6	6	6	6			9006-1		
07406C	0293005070		GASKET,FUEL INJECTION NOZZLE INR	6	6					9006-1		
07406D	0265081240		GASKET,FUEL INJECTION NOZZLE INR	12	12	12	12			9006-1		
07409	1506098100		CONNECTOR,FUEL INJECTION NOZZLE			6	6			9901-1		
07410A	1050313910		HOLDER ASSY,FUEL INJECTION NOZZLE	6	6					9006-1		
	1050414130		HOLDER ASSY,FUEL INJECTION NOZZLE			6	6			9901-1		
07414	1506448900		JOINT,FUEL INJECTION NOZZLE HOLDER	6	6					9006-1		
07416	1505602100		SEAT,FUEL INJECTION NOZZLE HOLDER			6	6			9901-1		
07416B	1505602001		SEAT,FUEL INJECTION NOZZLE HOLDER			6	6			9901-1		
07420	1050155330		NOZZLE,FUEL INJECTION	6	6					9006-1		
	1050190700		NOZZLE,FUEL INJECTION			6	6			9901-1		
07429	ME056679	#	TUBE,FUEL INJECTION 6.35X2.0X650 NO.4 C93020	1	1					9006-1	9304-2	
	ME056680	#	TUBE,FUEL INJECTION 6.35X2.0X650 NO.5 C93020	1	1					9006-1	9304-2	
	ME056681	#	TUBE,FUEL INJECTION 6.35X2.0X650 NO.6 C93020	1	1					9006-1	9304-2	
	ME157001	#	TUBE,FUEL INJECTION 6.35X2X650 NO.1C93020	1	1					9006-1	9304-2	
	ME157002	#	TUBE,FUEL INJECTION 6.35X2X650 NO.2C93020	1	1					9006-1	9304-2	
	ME157003	#	TUBE,FUEL INJECTION 6.35X2X650 NO.3C93020	1	1					9006-1	9304-2	
	ME157004		TUBE,FUEL INJECTION 6.35X2X650 STRAIGHT	AR	AR					9006-1		
	ME157709		TUBE,FUEL INJECTION 6.35X2.0X650 NO.1	1	1					9304-3		
	ME157710		TUBE,FUEL INJECTION 6.35X2.0X650 NO.2	1	1					9304-3		
	ME157711		TUBE,FUEL INJECTION 6.35X2.0X650 NO.5	1	1					9304-3		
	ME157712		TUBE,FUEL INJECTION 6.35X2.0X650 NO.6	1	1					9304-3		
	ME157453		TUBE,FUEL INJECTION 6.35X2X650 NO.3	1	1					9304-3		
	ME157454		TUBE,FUEL INJECTION 6.35X2X650 NO.4	1	1					9304-3		
	ME158222		TUBE,FUEL INJECTION 6.35X2.0X650 NO.2			1	1			9901-1		
	ME158223		TUBE,FUEL INJECTION 6.35X2.0X650 NO.3			1	1			9901-1		
	ME158224		TUBE,FUEL INJECTION 6.35X2.0X650 NO.4			1	1			9901-1		

13-410 INJECTION PIPE & NOZZLE

インジェクションパイプ & ノズル

04 6D240 CTJS04US1
 03 6D240 CTJS04000
 02 6D221 CTJS12131 COLD
 01 6D221 CTJS12000 STD

-119-

見出番号 REF.-NO.	部品番号 PART NO.	代 替 順 号 R I P / S C E N P O G	部品名称および記事・仕様記号 PART NAME & DESCRIPTION	型式・個数 MODEL & QTY						適用号機 APPLICABLE SERIAL NO.	管 区 M / R	新 規 V R D
				0	1	2	3	4				
				FROM@-@UPTO								
	ME158225		TUBE,FUEL INJECTION 6.35X2.0X650 NO.5			1	1			9901-1		
	ME158226		TUBE,FUEL INJECTION 6.35X2.0X650 NO.6			1	1			9901-1		
	ME158221		TUBE,FUEL INJECTION 6.35X2.2X650 NO.1			1	1			9901-1		
07432B	1505503600		PUSH ROD,FUEL INJECTION NOZZLE HOLDER	6	6					9006-1		
07432C	1505830000		PUSH ROD,FUEL INJECTION NOZZLE HOLDER L=36.06					CC	CC	9901-1		
	1505830100		PUSH ROD,FUEL INJECTION NOZZLE HOLDER L=36.07					CC	CC	9901-1		
	1505830200		PUSH ROD,FUEL INJECTION NOZZLE HOLDER L=36.08					CC	CC	9901-1		
	1505830300		PUSH ROD,FUEL INJECTION NOZZLE HOLDER L=36.09					CC	CC	9901-1		
	1505830400		PUSH ROD,FUEL INJECTION NOZZLE HOLDER L=36.10					CC	CC	9901-1		
	1505830500		PUSH ROD,FUEL INJECTION NOZZLE HOLDER L=36.11					CC	CC	9901-1		
	1505830600		PUSH ROD,FUEL INJECTION NOZZLE HOLDER L=36.12					CC	CC	9901-1		
	1505830700		PUSH ROD,FUEL INJECTION NOZZLE HOLDER L=36.13					CC	CC	9901-1		
	1505830800		PUSH ROD,FUEL INJECTION NOZZLE HOLDER L=36.14					CC	CC	9901-1		
	1505830900		PUSH ROD,FUEL INJECTION NOZZLE HOLDER L=36.15					CC	CC	9901-1		
	1505831000		PUSH ROD,FUEL INJECTION NOZZLE HOLDER L=36.16					CC	CC	9901-1		
	1505831100		PUSH ROD,FUEL INJECTION NOZZLE HOLDER L=36.17					CC	CC	9901-1		
	1505831200		PUSH ROD,FUEL INJECTION NOZZLE HOLDER L=36.18					CC	CC	9901-1		
	1505831300		PUSH ROD,FUEL INJECTION NOZZLE HOLDER L=36.19					CC	CC	9901-1		
	1505831400		PUSH ROD,FUEL INJECTION NOZZLE HOLDER L=36.20					CC	CC	9901-1		
	1505831500		PUSH ROD,FUEL INJECTION NOZZLE HOLDER L=36.21					CC	CC	9901-1		
	1505831600		PUSH ROD,FUEL INJECTION NOZZLE HOLDER L=36.22					CC	CC	9901-1		
	1505831700		PUSH ROD,FUEL INJECTION NOZZLE HOLDER L=36.23					CC	CC	9901-1		
	1505831800		PUSH ROD,FUEL INJECTION NOZZLE HOLDER L=36.24					CC	CC	9901-1		
	1505831900		PUSH ROD,FUEL INJECTION NOZZLE HOLDER L=36.25					CC	CC	9901-1		
	1505832000		PUSH ROD,FUEL INJECTION NOZZLE HOLDER L=36.26					CC	CC	9901-1		
	1505832100		PUSH ROD,FUEL INJECTION NOZZLE HOLDER					CC	CC	9901-1		

インジェクションパイプ & ノズル
13-410 INJECTION PIPE & NOZZLE

04 6D240 CTJS04US1
03 6D240 CTJS04000
02 6D221 CTJS12131 COLD
01 6D221 CTJS12000 STD

-120-

見出番号 REF.-NO.	部品番号 PART NO.	代 替 R / P	変 更 順 号 S C E N E O G	部品名称および記事・仕様記号 PART NAME & DESCRIPTION	型式・個数 MODEL & QTY					適用号機 APPLICABLE SERIAL NO.	管 区 M / R	新 規 V R D	
					0	1	2	3	4	FROM@			@UPTO
	1505832200			L=36.27 PUSH ROD,FUEL INJECTION NOZZLE HOLDER				CC	CC		9901-1		
	1505832300			L=36.28 PUSH ROD,FUEL INJECTION NOZZLE HOLDER				CC	CC		9901-1		
	1505832400			L=36.29 PUSH ROD,FUEL INJECTION NOZZLE HOLDER				CC	CC		9901-1		
	1505832500			L=36.30 PUSH ROD,FUEL INJECTION NOZZLE HOLDER				CC	CC		9901-1		
	1505832600			L=36.31 PUSH ROD,FUEL INJECTION NOZZLE HOLDER				CC	CC		9901-1		
	1505832700			L=36.32 PUSH ROD,FUEL INJECTION NOZZLE HOLDER				CC	CC		9901-1		
	1505832800			L=36.33 PUSH ROD,FUEL INJECTION NOZZLE HOLDER				CC	CC		9901-1		
	1505832900			L=36.34 PUSH ROD,FUEL INJECTION NOZZLE HOLDER				CC	CC		9901-1		
	1505833000			L=36.35 PUSH ROD,FUEL INJECTION NOZZLE HOLDER				CC	CC		9901-1		
	1505833100			L=36.36 PUSH ROD,FUEL INJECTION NOZZLE HOLDER				CC	CC		9901-1		
	1505833200			L=36.37 PUSH ROD,FUEL INJECTION NOZZLE HOLDER				CC	CC		9901-1		
	1505833300			L=36.38 PUSH ROD,FUEL INJECTION NOZZLE HOLDER				CC	CC		9901-1		
	1505833400			L=36.39 PUSH ROD,FUEL INJECTION NOZZLE HOLDER				CC	CC		9901-1		
	1505833500			L=36.40 PUSH ROD,FUEL INJECTION NOZZLE HOLDER				CC	CC		9901-1		
	1505833600			L=36.41 PUSH ROD,FUEL INJECTION NOZZLE HOLDER				CC	CC		9901-1		
	1505833700			L=36.42 PUSH ROD,FUEL INJECTION NOZZLE HOLDER				CC	CC		9901-1		
	1505833800			L=36.43 PUSH ROD,FUEL INJECTION NOZZLE HOLDER				CC	CC		9901-1		
	1505833900			L=36.44 PUSH ROD,FUEL INJECTION NOZZLE HOLDER				CC	CC		9901-1		
	1505834000			L=36.45 PUSH ROD,FUEL INJECTION NOZZLE HOLDER				CC	CC		9901-1		
	1505834100			L=36.46 PUSH ROD,FUEL INJECTION NOZZLE HOLDER				CC	CC		9901-1		
	1505834200			L=36.47 PUSH ROD,FUEL INJECTION NOZZLE HOLDER				CC	CC		9901-1		
	1505834300			L=36.48 PUSH ROD,FUEL INJECTION NOZZLE HOLDER				CC	CC		9901-1		
	1505834400			L=36.49 PUSH ROD,FUEL INJECTION NOZZLE HOLDER				CC	CC		9901-1		
	1505834500			L=36.50 PUSH ROD,FUEL INJECTION NOZZLE HOLDER				CC	CC		9901-1		
	1505834600			L=36.51 PUSH ROD,FUEL INJECTION NOZZLE HOLDER				CC	CC		9901-1		

インジェクションパイプ & ノズル
13-410 INJECTION PIPE & NOZZLE

04 6D240 CTJS04US1
03 6D240 CTJS04000
02 6D221 CTJS12131 COLD
01 6D221 CTJS12000 STD

-121-

見出番号 REF.-NO.	部品番号 PART NO.	代 替 R / P 記 順 S C / E N / Q G	部品名称および記事・仕様記号 PART NAME & DESCRIPTION	型式・個数 MODEL & QTY						適用号機 APPLICABLE SERIAL NO.		管 区 M / R	新 規 V / R D	
				0	1	2	3	4		FROM@-	@UPTO			
	1505834700		L=36.52 PUSH ROD,FUEL INJECTION NOZZLE HOLDER						CC	CC		9901-1		
	1505834800		L=36.53 PUSH ROD,FUEL INJECTION NOZZLE HOLDER						CC	CC		9901-1		
	1505834900		L=36.54 PUSH ROD,FUEL INJECTION NOZZLE HOLDER						CC	CC		9901-1		
	1505835000		L=36.55 PUSH ROD,FUEL INJECTION NOZZLE HOLDER						CC	CC		9901-1		
	1505835100		L=36.56 PUSH ROD,FUEL INJECTION NOZZLE HOLDER						CC	CC		9901-1		
	1505835200		L=36.57 PUSH ROD,FUEL INJECTION NOZZLE HOLDER						CC	CC		9901-1		
	1505835300		L=36.58 PUSH ROD,FUEL INJECTION NOZZLE HOLDER						CC	CC		9901-1		
	1505835400		L=36.59 PUSH ROD,FUEL INJECTION NOZZLE HOLDER						CC	CC		9901-1		
	1505835500		L=36.60 PUSH ROD,FUEL INJECTION NOZZLE HOLDER						CC	CC		9901-1		
	1505835600		L=36.61 PUSH ROD,FUEL INJECTION NOZZLE HOLDER						CC	CC		9901-1		
	1505835700		L=36.62 PUSH ROD,FUEL INJECTION NOZZLE HOLDER						CC	CC		9901-1		
	1505835800		L=36.63 PUSH ROD,FUEL INJECTION NOZZLE HOLDER						CC	CC		9901-1		
	1505835900		L=36.64 PUSH ROD,FUEL INJECTION NOZZLE HOLDER						CC	CC		9901-1		
	1505836000		L=36.65 PUSH ROD,FUEL INJECTION NOZZLE HOLDER						CC	CC		9901-1		
	1505836100		L=36.66 PUSH ROD,FUEL INJECTION NOZZLE HOLDER						CC	CC		9901-1		
	1505836200		L=36.67 PUSH ROD,FUEL INJECTION NOZZLE HOLDER						CC	CC		9901-1		
	1505836300		L=36.68 PUSH ROD,FUEL INJECTION NOZZLE HOLDER						CC	CC		9901-1		
	1505836400		L=36.69 PUSH ROD,FUEL INJECTION NOZZLE HOLDER						CC	CC		9901-1		
	1505836500		L=36.70 PUSH ROD,FUEL INJECTION NOZZLE HOLDER						CC	CC		9901-1		
	1505836600		L=36.71 PUSH ROD,FUEL INJECTION NOZZLE HOLDER						CC	CC		9901-1		
	1505836700		L=36.72 PUSH ROD,FUEL INJECTION NOZZLE HOLDER						CC	CC		9901-1		
	1505836800		L=36.73 PUSH ROD,FUEL INJECTION NOZZLE HOLDER						CC	CC		9901-1		
	1505836900		L=36.74 PUSH ROD,FUEL INJECTION NOZZLE HOLDER						CC	CC		9901-1		
	1505837000		L=36.75 PUSH ROD,FUEL INJECTION NOZZLE HOLDER						CC	CC		9901-1		
	1505837100		L=36.76 PUSH ROD,FUEL INJECTION NOZZLE HOLDER						CC	CC		9901-1		

インジェクションパイプ & ノズル
13-410 INJECTION PIPE & NOZZLE

04 6D240 CTJS04US1
03 6D240 CTJS04000
02 6D221 CTJS12131 COLD
01 6D221 CTJS12000 STD

-122-

見出番号 REF.-NO.	部品番号 PART NO.	代 替 R / P	変 更 順 号 S C E N E / Q G	部品名称および記事・仕様記号 PART NAME & DESCRIPTION	型式・個数 MODEL & QTY				適用号機 APPLICABLE SERIAL NO. FROM@-@UPTO	管 区 M / R	新 規 V R D	
					0	1	2	3				4
	1505837200			L=36.77 PUSH ROD,FUEL INJECTION NOZZLE HOLDER			CC	CC		9901-1		
	1505837300			L=36.78 PUSH ROD,FUEL INJECTION NOZZLE HOLDER			CC	CC		9901-1		
	1505837400			L=36.79 PUSH ROD,FUEL INJECTION NOZZLE HOLDER			CC	CC		9901-1		
	1505837500			L=36.80 PUSH ROD,FUEL INJECTION NOZZLE HOLDER			CC	CC		9901-1		
	1505837600			L=36.81 PUSH ROD,FUEL INJECTION NOZZLE HOLDER			CC	CC		9901-1		
	1505837700			L=36.82 PUSH ROD,FUEL INJECTION NOZZLE HOLDER			CC	CC		9901-1		
	1505837800			L=36.83 PUSH ROD,FUEL INJECTION NOZZLE HOLDER			CC	CC		9901-1		
	1505837900			L=36.84 PUSH ROD,FUEL INJECTION NOZZLE HOLDER			CC	CC		9901-1		
	1505838000			L=36.85 PUSH ROD,FUEL INJECTION NOZZLE HOLDER			CC	CC		9901-1		
	1505838100			L=36.86 PUSH ROD,FUEL INJECTION NOZZLE HOLDER			CC	CC		9901-1		
	1505838200			L=36.87 PUSH ROD,FUEL INJECTION NOZZLE HOLDER			CC	CC		9901-1		
	1505838300			L=36.88 PUSH ROD,FUEL INJECTION NOZZLE HOLDER			CC	CC		9901-1		
	1505838400			L=36.89 PUSH ROD,FUEL INJECTION NOZZLE HOLDER			CC	CC		9901-1		
	1505838500			L=36.90 PUSH ROD,FUEL INJECTION NOZZLE HOLDER			CC	CC		9901-1		
	1505838600			L=36.91 PUSH ROD,FUEL INJECTION NOZZLE HOLDER			CC	CC		9901-1		
	1505838700			L=36.92 PUSH ROD,FUEL INJECTION NOZZLE HOLDER			CC	CC		9901-1		
	1505838800			L=36.93 PUSH ROD,FUEL INJECTION NOZZLE HOLDER			CC	CC		9901-1		
	1505838900			L=36.94 PUSH ROD,FUEL INJECTION NOZZLE HOLDER			CC	CC		9901-1		
07433B	1505391620			L=36.95 SHIM,FUEL INJECTION NOZZLE			6	6		9901-1		
	1505900600			T=0.400 SHIM,FUEL INJECTION NOZZLE			CC	CC		9901-1		
	1505900700			T=0.500 SHIM,FUEL INJECTION NOZZLE			CC	CC		9901-1		
	1505900800			T=0.520 SHIM,FUEL INJECTION NOZZLE			CC	CC		9901-1		
	1505900900			T=0.540 SHIM,FUEL INJECTION NOZZLE			CC	CC		9901-1		
	1505901000			T=0.560 SHIM,FUEL INJECTION NOZZLE			CC	CC		9901-1		
	1505901100			T=0.580 SHIM,FUEL INJECTION NOZZLE			CC	CC		9901-1		

13-410 INJECTION PIPE & NOZZLE

インジェクションパイプ & ノズル

04 6D240 CTJS04US1
 03 6D240 CTJS04000
 02 6D221 CTJS12131 COLD
 01 6D221 CTJS12000 STD

-123-

見出番号 REF.-NO.	部品番号 PART NO.	代 替 R / P 記 号 S C E N E P Q G	部品名称および記事・仕様記号 PART NAME & DESCRIPTION	型式・個数 MODEL & QTY					適用号機 APPLICABLE SERIAL NO.	管 区 M / R	新 規 V R D	
				0	1	2	3	4				FROM@
07433C	1505901200		SHIM,FUEL INJECTION NOZZLE T=0.600				CC	CC		9901-1		
	1505901300		SHIM,FUEL INJECTION NOZZLE T=0.700				CC	CC		9901-1		
	1505390700		SHIM,FUEL INJECTION NOZZLE T=0.400				CC	CC		9901-1		
	1505390800		SHIM,FUEL INJECTION NOZZLE T=0.500				CC	CC		9901-1		
	1505390900		SHIM,FUEL INJECTION NOZZLE T=0.520				CC	CC		9901-1		
	1505391000		SHIM,FUEL INJECTION NOZZLE T=0.540				CC	CC		9901-1		
	1505391100		SHIM,FUEL INJECTION NOZZLE T=0.560				CC	CC		9901-1		
	1505391200		SHIM,FUEL INJECTION NOZZLE T=0.580				CC	CC		9901-1		
	1505391300		SHIM,FUEL INJECTION NOZZLE T=0.600				CC	CC		9901-1		
	1505391400		SHIM,FUEL INJECTION NOZZLE T=0.700				CC	CC		9901-1		
07434B	1505621400		SPRING,FUEL INJECTION NOZZLE HOLDER	6	6					9006-1		
	1505626600		SPRING,FUEL INJECTION NOZZLE HOLDER			6	6			9901-1		
07434C	1505626500		SPRING,FUEL INJECTION NOZZLE HOLDER			6	6			9901-1		
07486F	1506241800		SPACER,FUEL INJECTION NOZZLE			6	6			9901-1		
07488B	1505652001		SCREW,FUEL INJECTION NOZZLE	6	6					9006-1		
07491	1505083300		PIN,FUEL INJECTION NOZZLE	12	12					9006-1		
07491B	1505251700		PIN,FUEL INJECTION NOZZLE			12	12			9901-1		
07493B	1506501701		NUT,FUEL INJECTION NOZZLE	6	6					9006-1		
	1506515400		NUT,FUEL INJECTION NOZZLE			6	6			9901-1		
07493C	1505677100		NUT,FUEL INJECTION NOZZLE	6	6					9006-1		
07494	MH000657		BOLT,FUEL INJECTION NOZZLE FLANGE,8X56	12	12	12	12			9006-1		
07495	ME930001		STAY,FUEL INJECTION TUBE	1	1	1	1			9006-1		
07498B	MH020258		CLAMP,FUEL INJECTION TUBE D=6X2	9	9					9006-1	9304-2	
07498C	MH020259		CLAMP,FUEL INJECTION TUBE D=6X2	3	3					9006-1	9304-2	
07498F	MH020293		CLAMP,FUEL INJECTION TUBE D=6X2	11	11	11	11			9304-3		
07498G	MH020294		CLAMP,FUEL INJECTION TUBE D=6X2	3	3	3	3			9304-3		
07499	MF140009		BOLT,FUEL INJECTION TUBE FLANGE,6X25	6	6					9006-1	9304-2	
07499B	MH000706		BOLT,FUEL INJECTION TUBE FLANGE,10X16	1	1	1	1			9006-1		
07499C	MF240031		BOLT,FUEL INJECTION TUBE WASHER ASSEMBLED,6X30	7	7					9304-3	9911-1	
	MF241232		BOLT,FUEL INJECTION TUBE WASHER ASSEMBLED,6X32	7	7					9911-2		
	MF241230		BOLT,FUEL INJECTION TUBE	1	1					0203-2		

13 -420 フュ-エル リターン ホース
FUEL RETURN HOSE

-126-

6D22-T

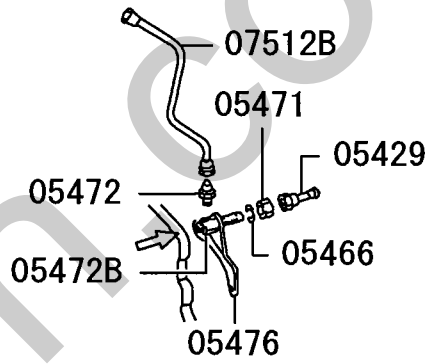
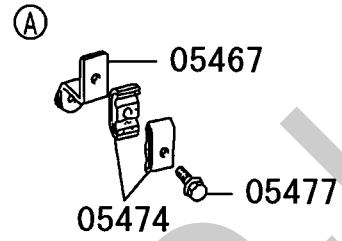
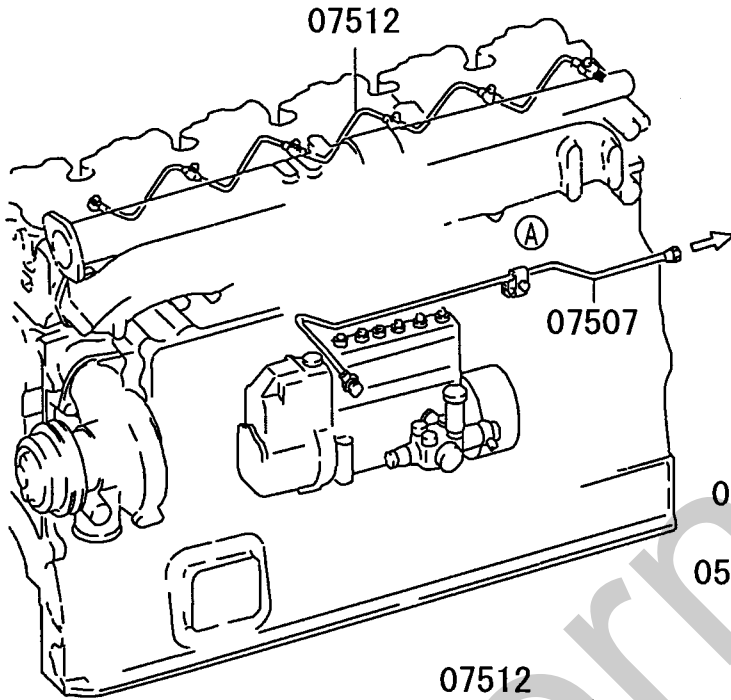

6D24-T

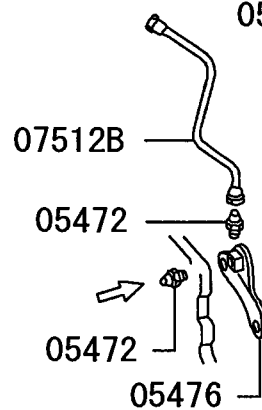
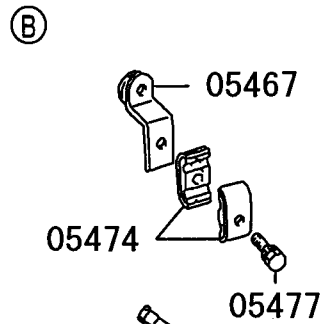
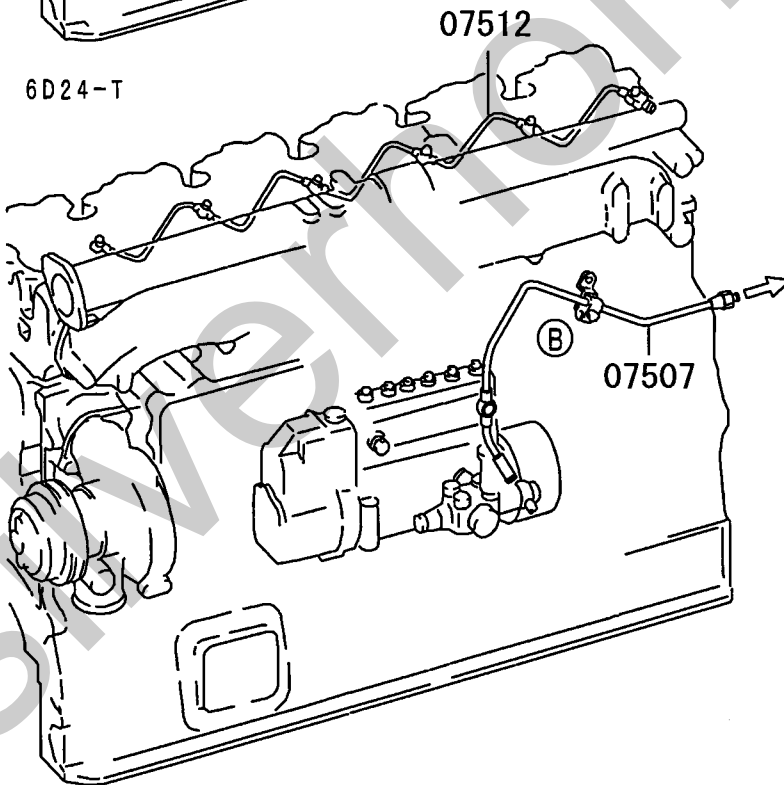

217T01

13 -420 FUEL RETURN HOSE

フューエルリターンホース

04 6D240 CTJS04US1
 03 6D240 CTJS04000
 02 6D221 CTJS12131 COLD
 01 6D221 CTJS12000 STD

-127-

見出番号 REF.-NO.	部品番号 PART NO.	代 替 R / P	変 更 記 号 S C E N E P O G	部品名称および記事・仕様記号 PART NAME & DESCRIPTION	型式・個数 MODEL & QTY					適用号機 APPLICABLE SERIAL NO. FROM@-@UPTO	管 区 M / R	新 規 V / R D	
					0	1	2	3	4				
05429	ME039462			PIPE,FUEL RETURN	1	1					9006-1		
05466	F251514000			WASHER,FUEL RETURN LINE SPRING,14	1	1					9006-1		
05467	ME059508			STAY,FUEL RETURN LINE	1	1					9006-1		
	MH023119			STAY,FUEL RETURN LINE			1	1			9901-1		
05471	F232014000			NUT,FUEL RETURN LINE JAM,14	1	1					9006-1		
05472	MH038906			JOINT,FUEL RETURN LINE	1	1					9006-1		
	MH038906			JOINT,FUEL RETURN LINE			2	2			9901-1		
05472B	3193343600			JOINT,FUEL RETURN LINE	1	1					9006-1		
05474	MH021233			CLAMP,FUEL RETURN LINE D=6X2	2	2	2	2			9006-1		
05476	3096105500			BRACKET,FUEL RETURN LINE	1	1					9006-1		
	ME158019			BRACKET,FUEL RETURN LINE			1	1			9901-1		
05477	MF140013			BOLT,FUEL RETURN LINE FLANGE,6X35	1	1					9006-1	0006-3	
	MF140213			BOLT,FUEL RETURN LINE FLANGE,6X35	1	1					0007-1		
	MF140013			BOLT,FUEL RETURN LINE FLANGE,6X35			1	1			9901-1	0006-3	
	MF140213			BOLT,FUEL RETURN LINE FLANGE,6X35			1	1			0007-1		
07507	ME059592			TUBE,INJECTION PUMP FUEL OVERFLOW	1	1					9006-1		
	ME158479			TUBE,INJECTION PUMP FUEL OVERFLOW 8			1	1			9901-1		
07512	ME056323	R		TUBE,FUEL INJECTION NOZZLE FUEL RETURN 6.35	1	1					9006-1	9112-3	
	(ME056925) ME056925			TUBE,FUEL INJECTION NOZZLE FUEL RETURN 6.35	1	1					9201-1		
	ME056925			TUBE,FUEL INJECTION NOZZLE FUEL RETURN 6.35			1	1			9901-1		
07512B	ME059630			TUBE,FUEL INJECTION NOZZLE FUEL RETURN	1	1	1	1			9006-1		

14 -110 WATER PUMP & FAN
 ウォータポンプ & ファン

-128-

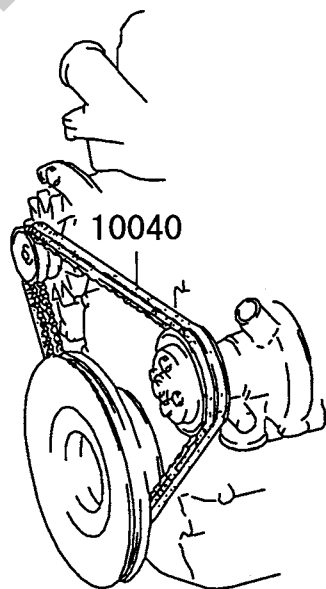
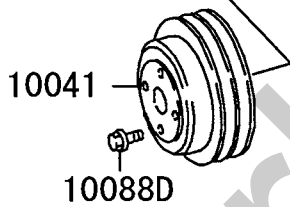
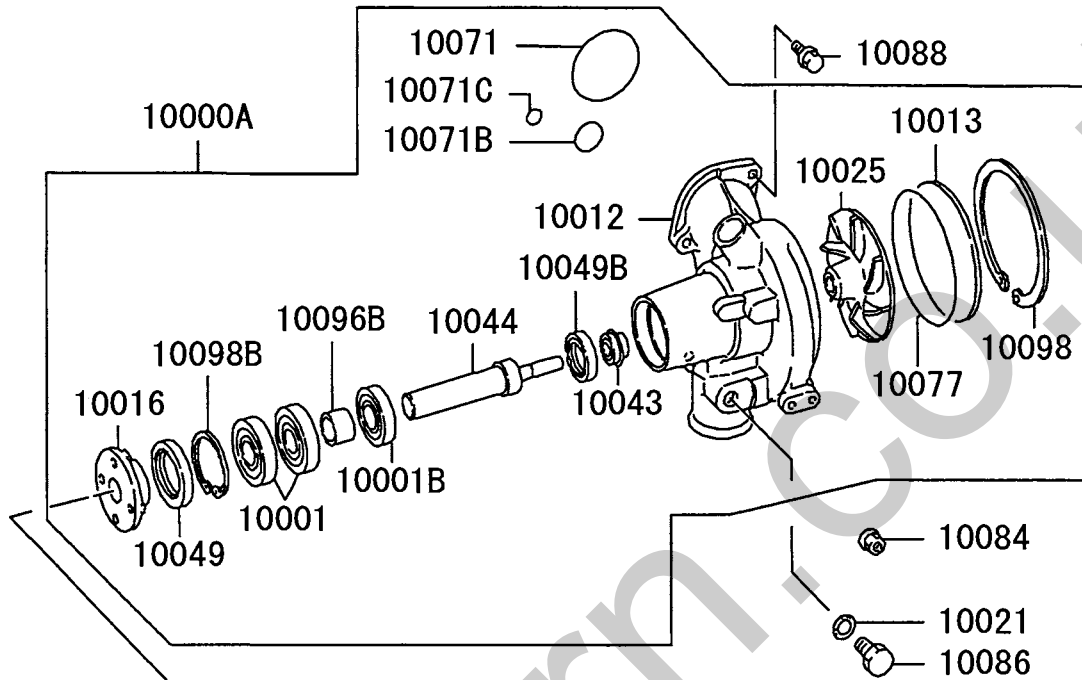

PNC
 10001, 10001B, 10025, 10043
 10044, 10049, 10049B, 10071
 10071B, 10071C, 10077

217T01

ウォーターポンプ & ファン
14 -110 WATER PUMP & FAN

04 6D240 CTJS04US1
03 6D240 CTJS04000
02 6D221 CTJS12131 COLD
01 6D221 CTJS12000 STD

-129-

見出番号 REF.-NO.	部品番号 PART NO.	代 替 順 号 R S C E N E P Q G	部品名称および記事・仕様記号 PART NAME & DESCRIPTION	型式・個数 MODEL & QTY					適用号機 APPLICABLE SERIAL NO.		管 区 M V R D	新 規 M V R D	
				0	1	2	3	4	FROM@	@UPTO			
10000A	ME996849 (ME995231)	3	WATER PUMP ASSY	1	1					9006-1	9801-3		
	ME995231		WATER PUMP ASSY	1	1					9802-1			
	ME995231		WATER PUMP ASSY			1	1			9901-1			
10001	F801006305		BEARING,WATER PUMP BALL	2	2	2	2			9006-1			
10001B	F800606205		BEARING,WATER PUMP BALL	1	1	1	1			9006-1			
10010	ME997002 (ME995285)	3	WATER PUMP KIT	1	1					9006-1	9801-3		
	ME995285 (ME995572)	3	WATER PUMP KIT	1	1					9802-1			
	ME995285 (ME995572)	3	WATER PUMP KIT			1	1			9901-1			
10012	ME157053		CASE,WATER PUMP	1	1	1	1			9006-1			
10013	ME055147		COVER,WATER PUMP	1	1	1	1			9006-1			
10016	ME055392		FLANGE,WATER PUMP PULLEY DRIVE	1	1	1	1			9006-1			
10021	F420216000		GASKET,WATER PUMP 16	1	1	1	1			9006-1			
10025	ME055398		IMPELLER,WATER PUMP	1	1	1	1			9006-1			
10040	ME900703		BELT,ALTERNATOR & OTHERS 1800X2		1					9006-1	9708-2		
	ME900715 (MH014510)	3	BELT,ALTERNATOR & OTHERS 1695X2	1						9006-1			
	ME900708	3	BELT,ALTERNATOR & OTHERS 1705X2		1					9708-3			
	(ME900767) ME900715	3	BELT,ALTERNATOR & OTHERS 1695X2			1	1			9901-1			
10041	ME055315		PULLEY,WATER PUMP	1	1	1	1			9006-1			
10043	ME150307 (ME241056)	3	SEAL UNIT,WATER PUMP SHAFT	1	1					9006-1	9801-3		
	ME241056		SEAL UNIT,WATER PUMP SHAFT	1	1					9802-1			
	ME241056		SEAL UNIT,WATER PUMP SHAFT			1	1			9901-1			
10044	ME055393		SHAFT,WATER PUMP	1	1					9006-1	9801-3		
	ME158685		SHAFT,WATER PUMP	1	1					9802-1			
	ME158685		SHAFT,WATER PUMP			1	1			9901-1			
10049	ME150299		OIL SEAL,WATER PUMP SHAFT	1	1	1	1			9006-1			
10049B	ME055395		OIL SEAL,WATER PUMP SHAFT	1	1	1	1			9006-1			
10071	MH035619		O-RING,WATER PUMP 75	1	1	1	1			9006-1			
10071B	MH035622		O-RING,WATER PUMP 29	1	1	1	1			9006-1			
10071C	MH035092		O-RING,WATER PUMP 14	1	1	1	1			9006-1			
10077	MH035620		O-RING,WATER PUMP INR 125	1	1	1	1			9006-1			
10084	MF434105		NUT,WATER PUMP	2	2	2	2			9006-1			

ウォーターパイプ & サーマスタット
14 -120 WATER PIPE & THERMOSTAT

-132-

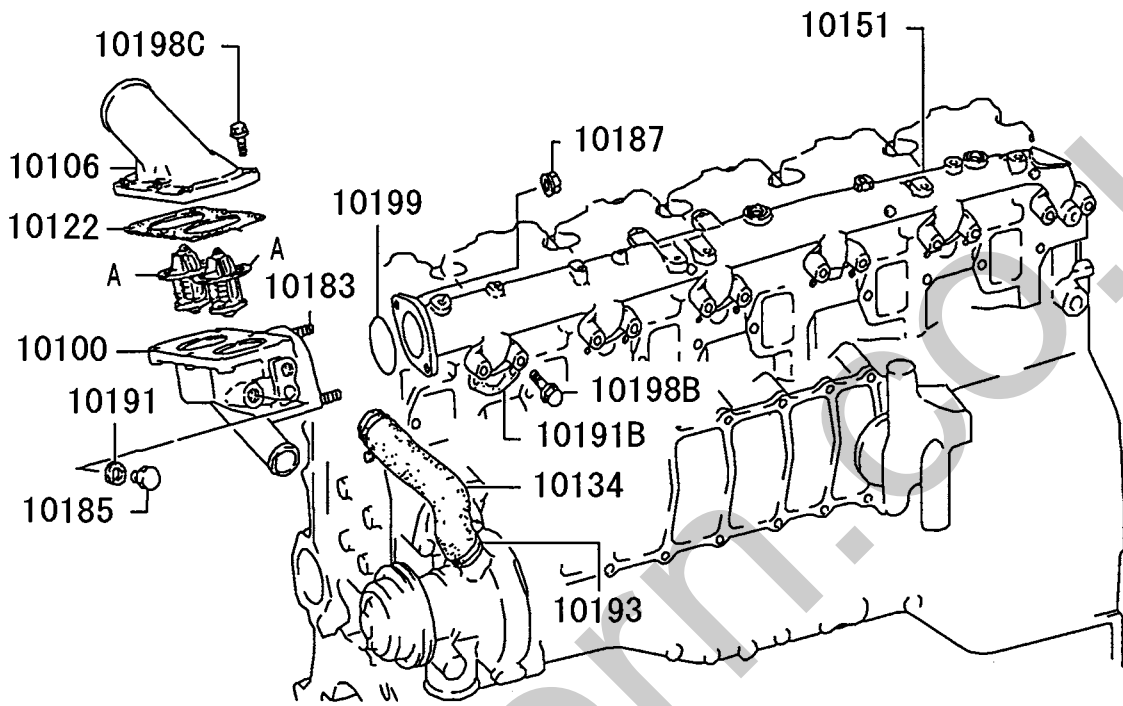

10898B



10110

PNC
10122, AX2

A: THERMOSTAT

217T01

ウォーターパイプ & サーマスタット
14 -120 WATER PIPE & THERMOSTAT

04 6D240 CTJS04US1
03 6D240 CTJS04000
02 6D221 CTJS12131 COLD
01 6D221 CTJS12000 STD

-133-

見出番号 REF.-NO.	部品番号 PART NO.	代 替 R / P	変 更 順 号 S C E N E P O G	部品名称および記事・仕様記号 PART NAME & DESCRIPTION	型式・個数 MODEL & QTY						適用号機 APPLICABLE SERIAL NO.	管 区 M / R	新 規 V R D
					0	1	2	3	4	FROM@	@UPTO		
10100	ME059413			CASE,THERMOSTAT	1	1	1	1			9006-1		
10106	ME059420			COVER,THERMOSTAT CASE	1	1	1	1			9006-1		
10110	ME996002	3		THERMOSTAT KIT 76.5°CX2	1	1					9006-1	9412-3	
	(ME996003)												
	ME996003			THERMOSTAT KIT 76.5°CX2	1	1					9501-1		
	ME996003			THERMOSTAT KIT 76.5°CX2			1	1			9901-1		
10122	ME055402	3		GASKET,THERMOSTAT COVER	1	1					9006-1	9412-3	
	(ME120978)												
	ME120978			GASKET,THERMOSTAT COVER	1	1					9501-1		
	ME120978			GASKET,THERMOSTAT COVER			1	1			9901-1		
10134	ME059271			HOSE,THERMOSTAT WATER BY-PASS	1	1	1	1			9006-1		
10151	ME055339	R		PIPE,COOLING WATER OUTLET	1	1					9006-1	9501-3	
	(ME150883)												
	ME150883			PIPE,COOLING WATER OUTLET	1	1					9502-1		
	ME150883			PIPE,COOLING WATER OUTLET			1	1			9901-1		
10183	MF406285			STUD,COOLING WATER LINE 10X22	2	2	2	2			9006-1		
10185	M0001300			PLUG,COOLING WATER LINE SCREW,16	1	1	1	1			9006-1		
10187	MF434105			NUT,COOLING WATER LINE FLANGE,10	2	2	2	2			9006-1		
10191	F420216000			GASKET,COOLING WATER LINE 16	1	1	1	1			9006-1		
10191B	3094600500	R		GASKET,COOLING WATER LINE FOR,CYLINDER HEAD	6	6					9006-1	9412-3	
	(ME150855)												
	ME150855			GASKET,COOLING WATER LINE	6	6					9501-1		
	ME150855			GASKET,COOLING WATER LINE			6	6			9901-1		
10193	MH020380			CLIP,COOLING WATER LINE D=45	2	2					9006-1	9209-3	
	MH021375			CLIP,COOLING WATER LINE D=32-50	2	2					9210-1		
	MH021375			CLIP,COOLING WATER LINE D=32-50			2	2			9901-1		
10198B	MH000708			BOLT,COOLING WATER LINE FLANGE,10X45	12	12					9006-1	0208-3	
	MS146014			BOLT,COOLING WATER LINE FLANGE,10X45	12	12					0209-1		
	MH000708			BOLT,COOLING WATER LINE FLANGE,10X45			12	12			9901-1	0208-3	
	MS146014			BOLT,COOLING WATER LINE FLANGE,10X45			12	12			0209-1		
10198C	MH000714			BOLT,COOLING WATER LINE FLANGE,10X25	6	6					9006-1	0005-3	
	MS146006			BOLT,COOLING WATER LINE FLANGE,10X25	6	6					0006-1		
	MH000714			BOLT,COOLING WATER LINE			6	6			9901-1	0005-3	

インレット マニホールド
15-210 INLET MANIFOLD

-136-

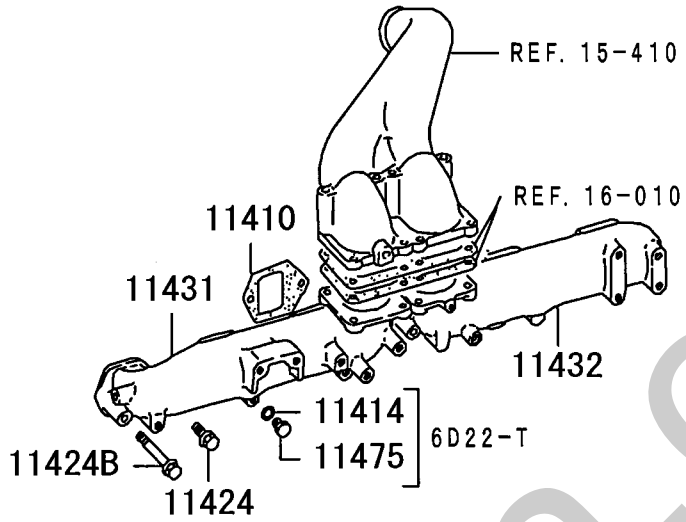

217T01

15 -210 INLET MANIFOLD

インレットマニホールド

04 6D240 CTJS04US1
 03 6D240 CTJS04000
 02 6D221 CTJS12131 COLD
 01 6D221 CTJS12000 STD

-137-

見出番号 REF.-NO.	部品番号 PART NO.	代 替 R / P 記 順 号 S C E N Q G	部品名称および記事・仕様記号 PART NAME & DESCRIPTION	型式・個数 MODEL & QTY						適用号機 APPLICABLE SERIAL NO.		管 区 M / R 新 規 V R D
				0	1	2	3	4		FROM@-	@UPTO	
11410	3093000501 (ME150051)	R	GASKET,INLET MANIFOLD	6	6					9006-1	9412-3	
	ME150051		GASKET,INLET MANIFOLD	6	6					9501-1		
	ME150051		GASKET,INLET MANIFOLD			6	6			9901-1		
11414	F420210000		GASKET,INLET MANIFOLD COVER 10	1	1					9602-1		
11424	MH000714		BOLT,INLET MANIFOLD,NO.1 FLANGE,10X25	6	6	6	6			9006-1		
11424B	MH000732		BOLT,INLET MANIFOLD,NO.1 FLANGE,10X95	6	6	6	6			9006-1		
11431	ME050717		MANIFOLD,INLET,FR	1	1					9006-1	9601-3	
	ME158104		MANIFOLD,INLET,FR	1	1					9602-1		
	ME158104		MANIFOLD,INLET,FR			1	1			9901-1		
11432	ME157250		MANIFOLD,INLET,RR	1	1	1	1			9006-1		
11475	ME031088		PLUG,INLET MANIFOLD SCREW,10	1	1					9602-1		

エキゾーストマニホールド
15-310 EXHAUST MANIFOLD

-138-

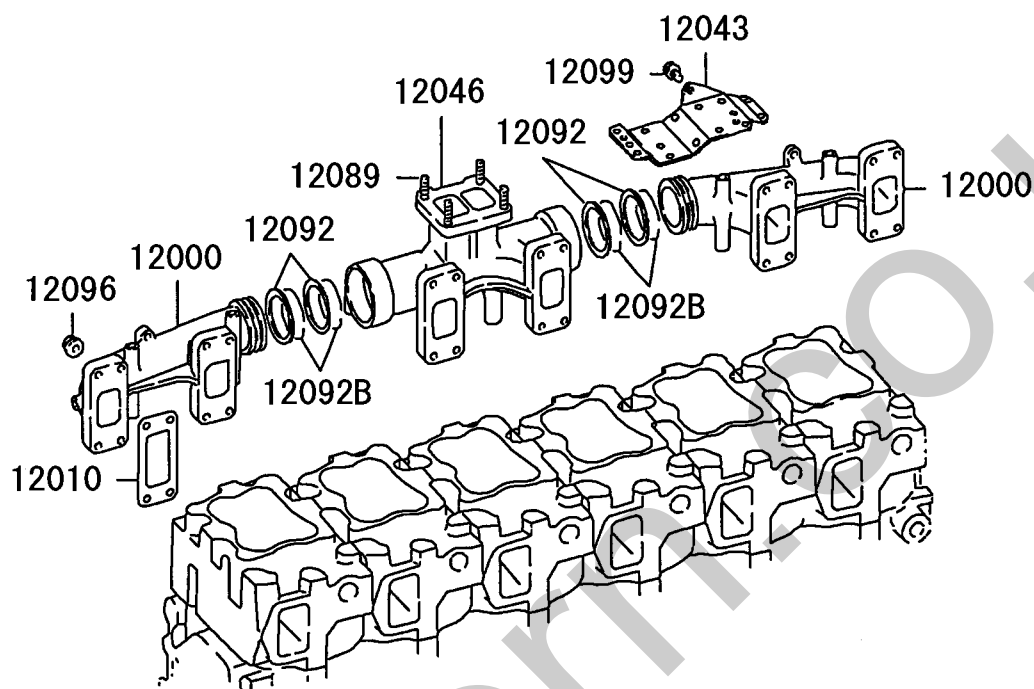

217T01

15-310 EXHAUST MANIFOLD

エキゾーストマニホールド

04 6D240 CTJS04US1
 03 6D240 CTJS04000
 02 6D221 CTJS12131 COLD
 01 6D221 CTJS12000 STD

-139-

見出番号 REF.-NO.	部品番号 PART NO.	代 替 R / P	変 更 順 号 S C E N Q G	部品名称および記事・仕様記号 PART NAME & DESCRIPTION	型式・個数 MODEL & QTY							適用号機 APPLICABLE SERIAL NO.		管 区 M / R	新 規 V R D	
					0	1	2	0	3	0	4					FROM@
12000	ME053946 (ME152481)	R		MANIFOLD,EXHAUST	2	2							9006-1	9610-3		
	ME152481			MANIFOLD,EXHAUST	2	2							9611-1			
	ME152481			MANIFOLD,EXHAUST			2	2					9901-1			
12010	ME053112			GASKET,EXHAUST MANIFOLD	6	6	6	6					9006-1			
12043	ME150073			INSULATOR,EXHAUST MANIFOLD HEAT	1	1	1	1					9006-1			
12046	ME053862			MANIFOLD,EXHAUST,CTR	1	1	1	1					9006-1			
12089	MF407728			STUD,EXHAUST MANIFOLD 10X30	4	4							9006-1	0302-3		
	MH002154			STUD,EXHAUST MANIFOLD 10X15	4	4							0303-1			
	MF407728			STUD,EXHAUST MANIFOLD 10X30			4	4					9901-1	0302-3		
	MH002154			STUD,EXHAUST MANIFOLD 10X15			4	4					0303-1			
12092	ME053950			SEAL RING,EXHAUST MANIFOLD	4	4	4	4					9006-1			
12092B	ME053952			SEAL RING,EXHAUST MANIFOLD	4	4	4	4					9006-1			
12096	MH004054			NUT,EXHAUST MANIFOLD SELF LOCKING,FLANGE,10	24	24	24	24					9006-1			
12099	MH000392			BOLT,EXHAUST MANIFOLD WASHER ASSEMBLED,8X12	3	3	3	3					9006-1			

ターボチャージャー
15-410 TURBOCHARGER

-140-

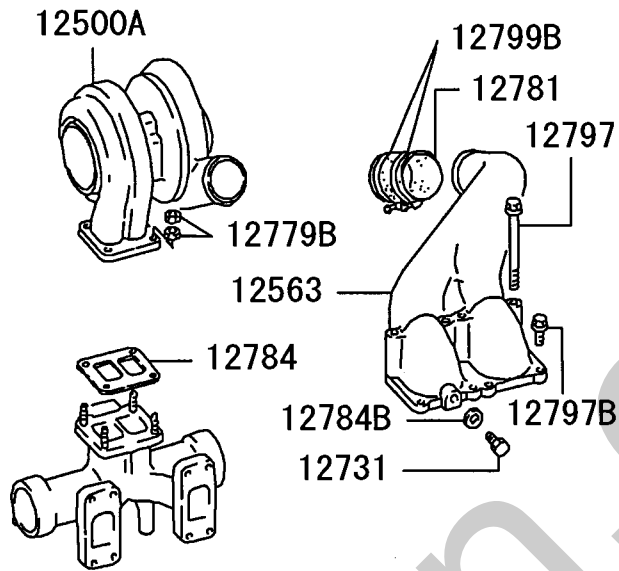

217T01

INNER PARTS

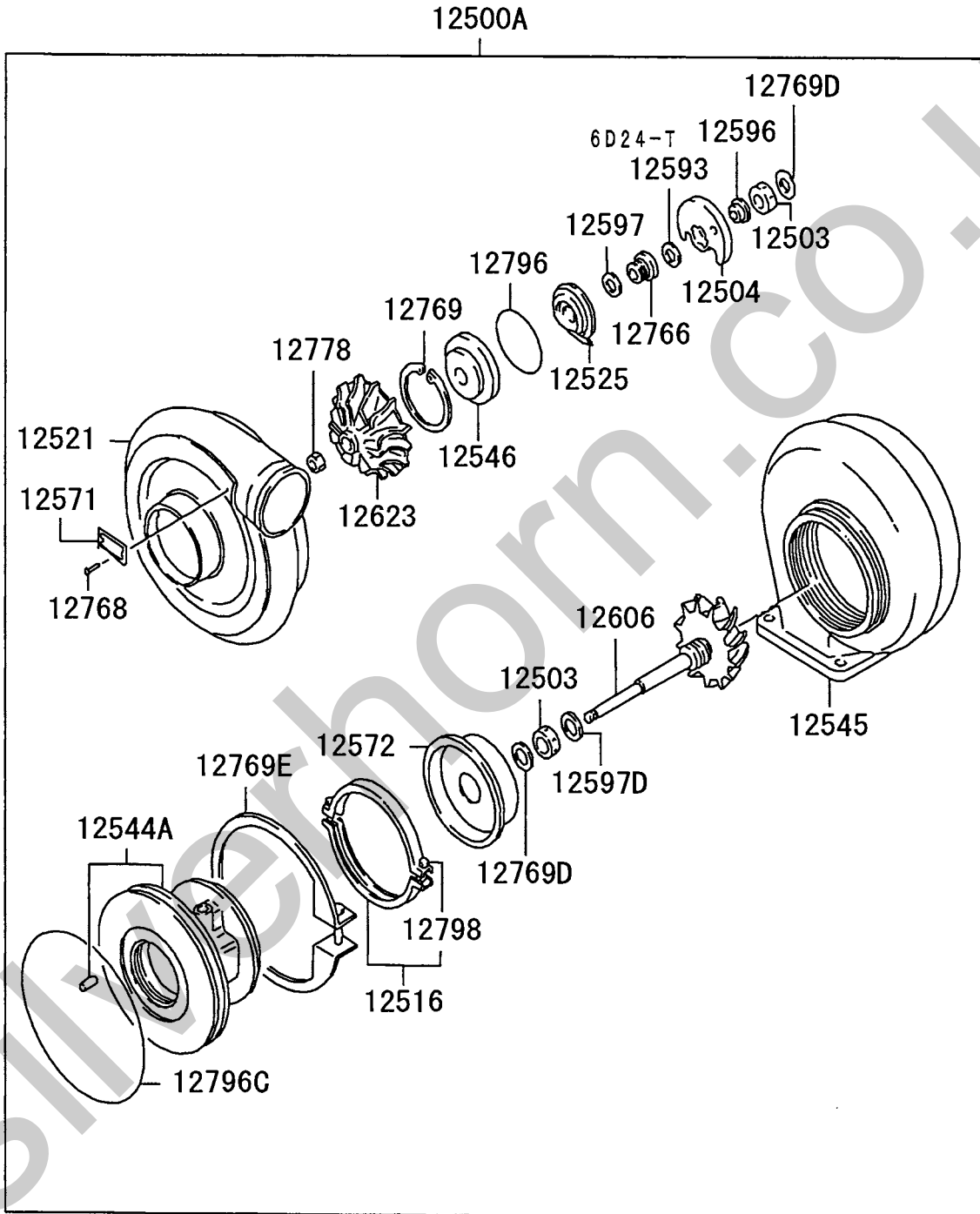

15-410 TURBOCHARGER

04 6D240 CTJS04US1
 03 6D240 CTJS04000
 02 6D221 CTJS12131 COLD
 01 6D221 CTJS12000 STD

-142-

見出番号 REF.-NO.	部品番号 PART NO.	代 替 順 号 R / S C E N E P O G	部品名称および記事・仕様記号 PART NAME & DESCRIPTION	型式・個数 MODEL & QTY					適用号機 APPLICABLE SERIAL NO.	管 区 M / R	新 規 V R D	
				0	1	2	3	4				FROM@-
				0	1	2	3	4				
12500A	4917400565		TURBOCHARGER ASSY TD08	1	1					9006-1		
	4918801661		TURBOCHARGER ASSY TD08			1	1			9901-1		
12503	4917421100 (4917421110)	3	BEARING,T/C SHAFT	2	2	2	2			9006-1		
12504	4918821500		THRUST BEARING,T/C	1	1	1	1			9006-1		
12516	4917414000		COUPLING,T/C HOUSING	1	1	1	1			9006-1		
12521	4917451300		COVER,T/C COMPRESSOR	1	1					9006-1		
	4918855120		COVER,T/C COMPRESSOR			1	1			9901-1		
12525	4917422200		DEFLECTOR,T/C OIL	1	1					9006-1		
	4918822210		DEFLECTOR,T/C OIL			1	1			9901-1		
12544A	1917425100		HOUSING ASSY,T/C BEARING	1	1					9006-1		
	4918825300		HOUSING ASSY,T/C BEARING			1	1			9901-1		
12545	4917410500		HOUSING,T/C TURBINE	1	1					9006-1	9706-2	
	4917410501		HOUSING,T/C TURBINE	1	1					9706-3		
	4918810400		HOUSING,T/C TURBINE			1	1			9901-1		
12546	4917422510		INSERT,T/C BEARING HOUSING	1	1					9006-1		
	4918822500		INSERT,T/C BEARING HOUSING			1	1			9901-1		
12563	ME050759		PIPE,T/C TO INLET MANIFOLD	1	1	1	1			9006-1		
12571	4916855200		NAME PLATE,T/C	1	1	1	1			9006-1		
12572	4917419100		PLATE,T/C TURBINE BACK	1	1					9006-1		
	4918819100		PLATE,T/C TURBINE BACK			1	1			9901-1		
12593	4918842300		RING,T/C SHAFT BEARING THRUST			1	1			9901-1		
12596	4918842400		RING,T/C SHAFT THRUST	1	1	1	1			9006-1		
12597	4917423100		RING,T/C SHAFT TURBINE PISTON	1	1	1	1			9006-1		
12597D	4918123100		RING,T/C SHAFT TURBINE PISTON	1	1	1	1			9006-1		
12606	4917430100	#	SHAFT & TURBINE,T/C T97020	1	1					9006-1	9706-2	
	4917430130		SHAFT & TURBINE,T/C	1	1					9706-3		
	4918830100	#	SHAFT & TURBINE,T/C T97020			1	1			9901-1		
12623	4917444200 (4917444201)	3	WHEEL,T/C COMPRESSOR	1	1					9006-1		
	4918845120		WHEEL,T/C COMPRESSOR			1	1			9901-1		
12731	ME031088		PLUG,T/C SCREW	1	1	1	1			9006-1		
12766	4917442130		SLEEVE,T/C INR	1	1					9006-1		
	4918842100		SLEEVE,T/C INR			1	1			9901-1		
12768	0066502048		RIVET,T/C INR	2	2					9006-1		
	0066502048		RIVET,T/C INR			1	1			9901-1		
12769	4917423200		SNAP RING,T/C INR	1	1	1	1			9006-1		
12769D	4917422300		SNAP RING,T/C INR	2	2	2	2			9006-1		
12769E	4917423300		SNAP RING,T/C INR	1	1	1	1			9006-1		
12778	4917442200		NUT,T/C INR	1	1					9006-1	9706-2	
	4913442200		NUT,T/C INR	1	1					9706-3		
	4917442200		NUT,T/C INR			1	1			9901-1		
12779B	MH004110		NUT,T/C 10	8	8	8	8			9006-1		
12781	ME053870		HOSE,T/C	1	1	1	1			9006-1		

ターボチャージャー
15-410 TURBOCHARGER

04 6D240 CTJS04US1
03 6D240 CTJS04000
02 6D221 CTJS12131 COLD
01 6D221 CTJS12000 STD

-143-

見出番号 REF.-NO.	部品番号 PART NO.	代 替 R / P	変 更 順 号 S C E N Q G	部品名称および記事・仕様記号 PART NAME & DESCRIPTION	型式・個数 MODEL & QTY					適用号機 APPLICABLE SERIAL NO.		管 区 M / R	新 規 V R D	
					0	1	2	3	4	FROM@	@UPTO			
12784	3003291200 (ME150877) ME150877 ME150877	3		63.5X65 GASKET,T/C	1	1					9006-1	9412-3		
				GASKET,T/C	1	1				9501-1				
				GASKET,T/C			1	1		9901-1				
12784B	F420210000			GASKET,T/C 10	1	1	1	1		9006-1				
12796	4917422600			O-RING,T/C INR	1	1	1	1		9006-1				
12796C	4917422700			O-RING,T/C INR	1	1	1	1		9006-1				
12797	MH000829			BOLT,T/C	4	4	4	4		9006-1				
12797B	MH000716			FLANGE,10X120										
				BOLT,T/C	4	4	4	4		9006-1				
12798	4916814020			FLANGE,10X55										
12799B	MH021370			BOLT,T/C INR	1	1	1	1		9006-1				
				CLAMP,T/C D=60-80	2	2	2	2		9006-1				

15-510 EXHAUST PIPE

-144-

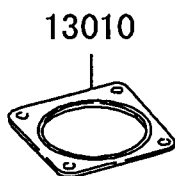
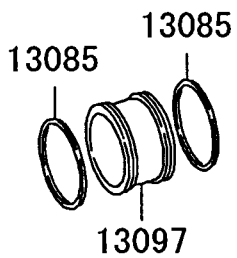

16-010 ^{スター} STARTER

-146-

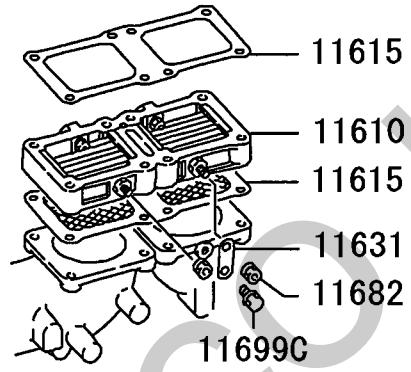
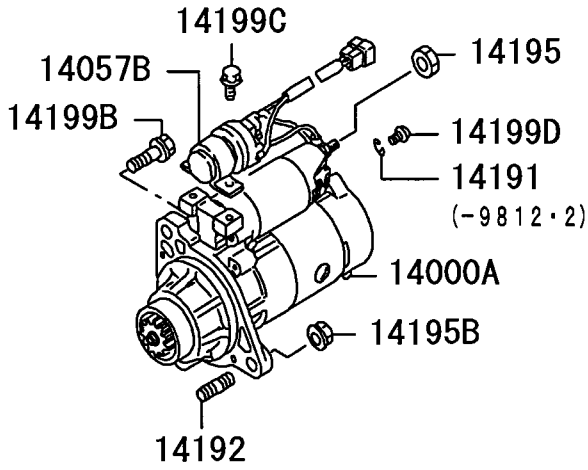

(-9708·2)

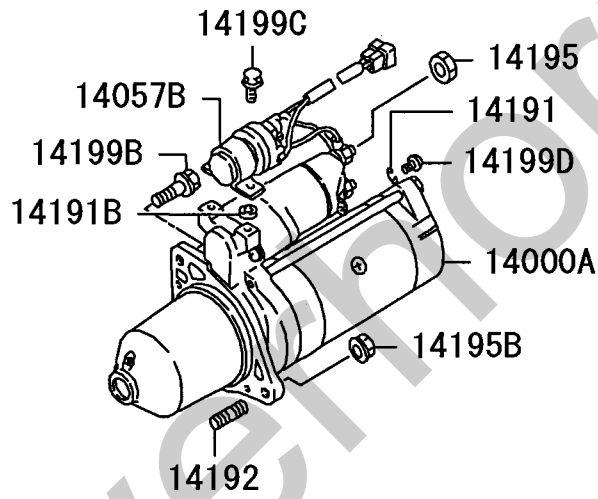

217T01

16-010 ^{スター}STARTER

-148-

INNER PARTS

14000A

ME152487 (24V-5.5KW)

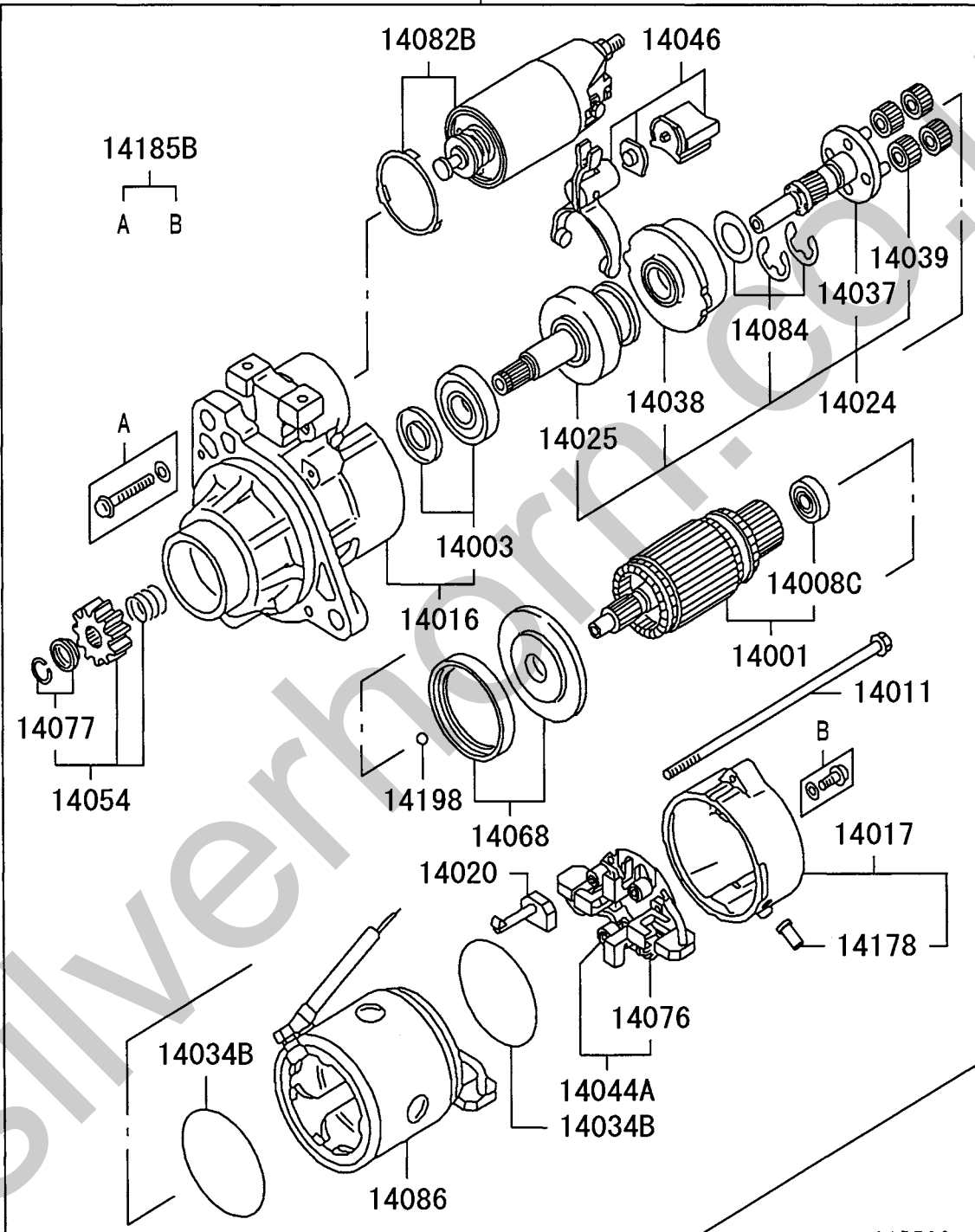

217T03

16-010 STARTER

04 6D240 CTJS04US1
 03 6D240 CTJS04000
 02 6D221 CTJS12131 COLD
 01 6D221 CTJS12000 STD

-149-

見出番号 REF.-NO.	部品番号 PART NO.	代 替 R / P	変 更 順 号 S C E N Q G	部品名称および記事・仕様記号 PART NAME & DESCRIPTION	型式・個数 MODEL & QTY							適用号機 APPLICABLE SERIAL NO.		管 区 M / R	新 規 V R D		
					0	1	2	3	4				FROM@			@UPTO	
11610	ME067539			HEATER,INTAKE AIR	1	1	1	1					9006-1				
11615	ME057663 (ME150067) ME057741	R		GASKET,INTAKE AIR HEATER	1	1							9006-1	9412-3			
	ME057741	3		GASKET,INTAKE AIR HEATER W/NET	1	1							9006-1	9412-3			
	(ME353132) ME150068			GASKET,INTAKE AIR HEATER W/NET	1	1							9501-1	0009-1			
	ME150067 ME150878			GASKET,INTAKE AIR HEATER GASKET,INTAKE AIR HEATER W/NET	1	1							9501-1				
	ME150068			GASKET,INTAKE AIR HEATER W/NET	1	1							0009-2				
	ME150067 ME150878			GASKET,INTAKE AIR HEATER GASKET,INTAKE AIR HEATER W/NET				1	1				9901-1	0009-1			
	ME150067 ME150878			GASKET,INTAKE AIR HEATER GASKET,INTAKE AIR HEATER W/NET				1	1				9901-1				
								1	1				0009-2				
11631	ME057329			PLATE,INTAKE AIR HEATER CABLE EARTH	1	1	1	1					9006-1				
11682	MF434103			NUT,INTAKE SILENCER FLANGE,6	2	2	2	2					9006-1				
11699C	MF140020			BOLT,INTAKE AIR HEATER FLANGE,8X10	1	1	1	1					9006-1				
14000A	M003T95082			STARTER ASSY 24V-5.5KW	1	1							9006-1	9708-2			
	M009T60171			STARTER ASSY 24V-5.5KW	1	1							9708-3				
	M009T60171			STARTER ASSY 24V-5.5KW				1	1				9901-1				
14001	M106X40471 M106X44371 (M106X44372)	3		ARMATURE KIT,STARTER ARMATURE KIT,STARTER	1	1							9006-1	9708-2			
	M106X44372 M106X44371 (M106X44372)	3		ARMATURE KIT,STARTER ARMATURE KIT,STARTER	1	1							9708-3	9907-3			
	M106X44372			ARMATURE KIT,STARTER	1	1							9908-1				
	M106X44371 (M106X44372)			ARMATURE KIT,STARTER				1	1				9901-1	9907-3			
	M106X44372			ARMATURE KIT,STARTER				1	1				9908-1				
14003	M690X00171			BEARING & SLEEVE KIT,STARTER	1	1							9006-1	9708-2			
	M690X00871			BEARING & SLEEVE KIT,STARTER	1	1							9708-3				
	M690X00871			BEARING & SLEEVE KIT,STARTER				1	1				9901-1				
14008	S930P28301			BEARING,STARTER ARMATURE	1	1							9006-1	9708-2			
14008B	S930P12370			BEARING,STARTER ARMATURE	1	1							9006-1	9708-2			
14008C	S930P28070			BEARING,STARTER ARMATURE	1	1							9006-1	9708-2			
	S930P29970			BEARING,STARTER ARMATURE	1	1							9708-3	9907-3			
	M931X01270			BEARING,STARTER ARMATURE	1	1							9908-1				
	S930P29970			BEARING,STARTER ARMATURE				1	1				9901-1	9907-3			
	M931X01270			BEARING,STARTER ARMATURE				1	1				9908-1				
14011	M981X76071			BOLT SET,STARTER	1	1	1	1					9006-1				
14011B	M901X02671			BOLT SET,STARTER	1	1							9006-1	9708-2			
14013	M646C71001			BRACKET,STARTER GEAR	1	1							9006-1	9708-2			
14015	M646B22301			BRACKET,STARTER,CTR	1	1							9006-1	9708-2			
14016	M641X71472			BRACKET,STARTER,FR	1	1							9006-1	9708-2			
	M641X83471			BRACKET,STARTER,FR	1	1							9708-3				

16-010 STARTER

04 6D240 CTJS04US1
 03 6D240 CTJS04000
 02 6D221 CTJS12131 COLD
 01 6D221 CTJS12000 STD

-150-

見出番号 REF.-NO.	部品番号 PART NO.	代 替 R / P	変 更 順 号 S C E N E Q G	部品名称および記事・仕様記号 PART NAME & DESCRIPTION	型式・個数 MODEL & QTY						適用号機 APPLICABLE SERIAL NO.		管 区 M / R	新 規 V R D	
					0	1	2	3	4	FROM@	@UPTO				
14017	M641X83471			BRACKET,STARTER,FR				1	1				9901-1		
	M644B20701			BRACKET,STARTER,RR	1	1							9006-1	9708-2	
	M642X36171			BRACKET,STARTER,RR	1	1							9708-3	0011-1	
	M642X48171			BRACKET,STARTER,RR	1	1							0011-2		
	M642X36171			BRACKET,STARTER,RR				1	1				9901-1	0011-1	
	M642X48171			BRACKET,STARTER,RR				1	1				0011-2		
14020	M648C27071			BRUSH,STARTER	2	2							9006-1	9708-2	
	M648X42171			BRUSH,STARTER	2	2							9708-3		
	M648X42171			BRUSH,STARTER				2	2				9901-1		
14024	M357X92871			CLUTCH KIT,STARTER PINION & REDUCTION	1	1	1	1				9708-3			
14025	M191T66171	3		CLUTCH,STARTER OVERRUNNING	1	1							9006-1	9708-2	
	(M191X66571)														
	M191X69571			CLUTCH,STARTER OVERRUNNING	1	1							9708-3		
	M191X69571			CLUTCH,STARTER OVERRUNNING				1	1				9901-1		
14028A	M232X14071			CAP ASSY,STARTER SWITCH	1	1						9006-1	9708-2		
14032	M212D12801			COVER,STARTER MAGNETIC SWITCH	1	1						9006-1	9708-2		
14034	M578D22601			GASKET,STARTER INR	1	1						9006-1	9708-2		
14034B	M578X31071			GASKET,STARTER INR	2	2	2	2				9708-3			
14034C	M578C22201			GASKET,STARTER INR	1	1						9006-1	9708-2		
14037	M357X67871			GEAR,STARTER REDUCTION	1	1	1	1				9708-3			
14037A	M357X61571			GEAR ASSY,STARTER REDUCTION	1	1						9006-1	9708-2		
14038	M135X02771			GEAR,STARTER REDUCTION INTERNAL	1	1	1	1				9708-3			
14039	M230X00971			GEAR,STARTER REDUCTION PINION	4	4	4	4				9708-3			
14044A	M649T07371			HOLDER ASSY,STARTER BRUSH	1	1						9006-1	9708-2		
	M649X21471			HOLDER ASSY,STARTER BRUSH	1	1						9708-3			
	M649X21471			HOLDER ASSY,STARTER BRUSH				1	1			9901-1			
14046	M863C06671	3		LEVER KIT,STARTER PINION SHIFT	1	1						9006-1	9708-2		
	(M863X10171)														
	M863X08972	R		LEVER KIT,STARTER PINION SHIFT	1	1						9708-3	9903-3		
	(M863X09274)														
	M863X09274			LEVER KIT,STARTER PINION SHIFT	1	1						9904-1			
	M863X08972	R		LEVER KIT,STARTER PINION SHIFT				1	1			9901-1	9903-3		
	(M863X09274)														
	M863X09274			LEVER KIT,STARTER PINION SHIFT				1	1			9904-1			
14054	M605X98871	3		PINION KIT,STARTER	1	1						9708-3	0210-3		
	(M605X77571)														
	M605X77571			PINION KIT,STARTER	1	1						0211-1			
	M605X98871	3		PINION KIT,STARTER				1	1			9901-1	0210-3		
	(M605X77571)														
	M605X77571			PINION KIT,STARTER				1	1			0211-1			
14056	M314X02371			PLATE,STARTER SWITCH TO TERMINAL	1	1						9006-1	9708-2		
14057B	3096600091			RELAY,STARTER SAFETY CONTROL	1	1						9006-1	9708-2		
	ME049300			RELAY,STARTER SAFETY CONTROL	1	1						9708-3			
	ME049300			RELAY,STARTER SAFETY CONTROL				1	1			9901-1			
14068	A640T31170			GASKET SET,STARTER YOKE	1	1						9006-1	9708-2		
	M578X30971			GASKET SET,STARTER YOKE	1	1						9708-3			
	M578X30971			GASKET SET,STARTER YOKE				1	1			9901-1			
14069	M816D00701			SEAL RING,STARTER	2	2					9006-1	9708-2			
14076	M391C02201			SPRING,STARTER BRUSH	4	4						9006-1	9708-2		
	M391X04571			SPRING,STARTER BRUSH	4	4						9708-3			

16-010 STARTER

04 6D240 CTJS04US1
 03 6D240 CTJS04000
 02 6D221 CTJS12131 COLD
 01 6D221 CTJS12000 STD

-151-

見出番号 REF.-NO.	部品番号 PART NO.	代 替 R / P	実 記 号 S C E N O G	部品名称および記事・仕様記号 PART NAME & DESCRIPTION	型式・個数 MODEL & QTY						適用号機 APPLICABLE SERIAL NO.		新 規 V R D	
					0	1	2	3	4		FROM@-	@UPTO		
14077	M391X04571			SPRING,STARTER BRUSH				4	4			9901-1		
	M385X05271			STOPPER KIT,STARTER PINION	1	1						9006-1	9708-2	
	M385X06771			STOPPER KIT,STARTER PINION	1	1						9708-3		
14082B	M385X06771			STOPPER KIT,STARTER PINION				1	1			9901-1		
	M371X21571			SWITCH KIT,STARTER MAGNETIC	1	1						9006-1	9708-2	
14084	M371X83271			SWITCH KIT,STARTER MAGNETIC	1	1						9708-3		
	M371X83271			SWITCH KIT,STARTER MAGNETIC				1	1			9901-1		
	M900X02071			WASHER SET,STARTER GEAR SHAFT	1	1						9006-1	9708-2	
14086	M982X38871			WASHER SET,STARTER GEAR SHAFT	1	1						9708-3		
	M982X38871			WASHER SET,STARTER GEAR SHAFT				1	1			9901-1		
	M800T44671			YOKE,STARTER	1	1						9006-1	9708-2	
14178	M800X74071			YOKE,STARTER	1	1						9708-3		
	M800X74071			YOKE,STARTER				1	1			9901-1		
	M256X08471			GROMMET,STARTER INR	1	1		1	1			0011-2		
14185	M986C10102			SCREW,STARTER INR	2	2					9006-1	9708-2		
14185B	A414X06671			SCREW,STARTER INR	1	1						9006-1	9708-2	
	M414X07472			SCREW,STARTER INR	1	1						9708-3		
14191	M414X07472			SCREW,STARTER INR				1	1			9901-1		
	F251505000			WASHER,STARTER SPRING,5	1	1						9006-1	9812-2	
14191B	MH005003			WASHER,STARTER PLAIN,9	2	2						9006-1	9708-2	
14192	F145012035			STUD,STARTER 12X35	1	1	1	1				9006-1		
14195	MH004186			NUT,STARTER 10	1	1	1	1				9006-1		
14195B	MF434106			NUT,STARTER FLANGE,12	1	1	1	1				9006-1		
14198	S409S00008			BALL,STARTER INR	1	1		1	1			9708-3		
14199B	MH000923			BOLT,STARTER FLANGE,12X35	2	2						9006-1	9404-3	
	MH000924	R		BOLT,STARTER FLANGE,12X40	2	2						9405-1		
14199C	(MH000840) MH000924	R		BOLT,STARTER FLANGE,12X40				2	2			9901-1		
	(MH000840) MF140005			BOLT,STARTER FLANGE,6X16	2	2						9006-1	0009-3	
	MH000999			BOLT,STARTER FLANGE,6X12	2	2						0010-1		
14199D	MF140005			BOLT,STARTER FLANGE,6X16				2	2			9901-1	0009-3	
	MH000999			BOLT,STARTER FLANGE,6X12				2	2			0010-1		
	F102505010			BOLT,STARTER 5X10	1	1						9006-1	9812-2	
	F160005010			BOLT,STARTER WASHER ASSEMBLED,5X10	1	1						9812-3		
	F160005010			BOLT,STARTER				1	1			9901-1		

16-110 ALTERNATOR & REGULATOR

-154-

CTJS12000
CTJS04

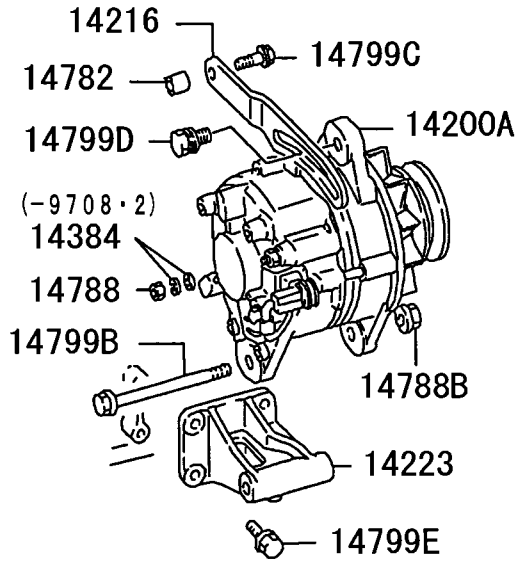

CTJS12131

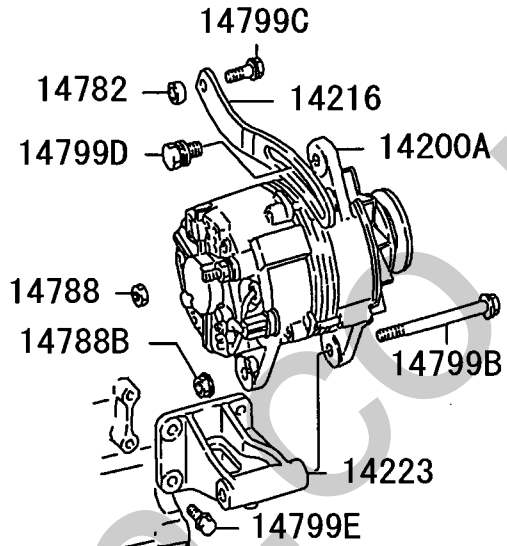

CTJS12131 (-9708.2)

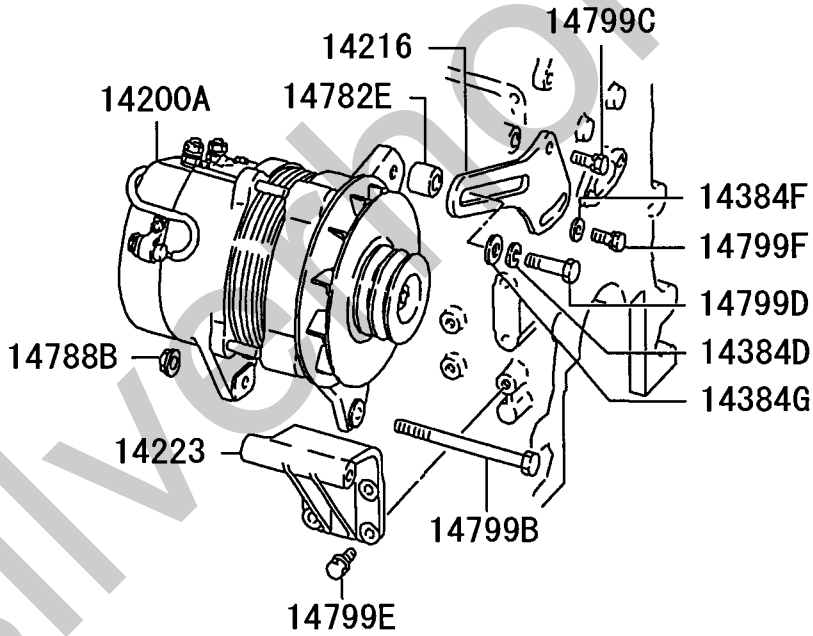

CTJS12131

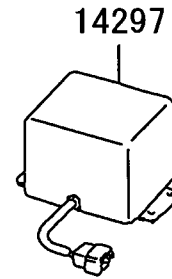

217T01

INNER PARTS

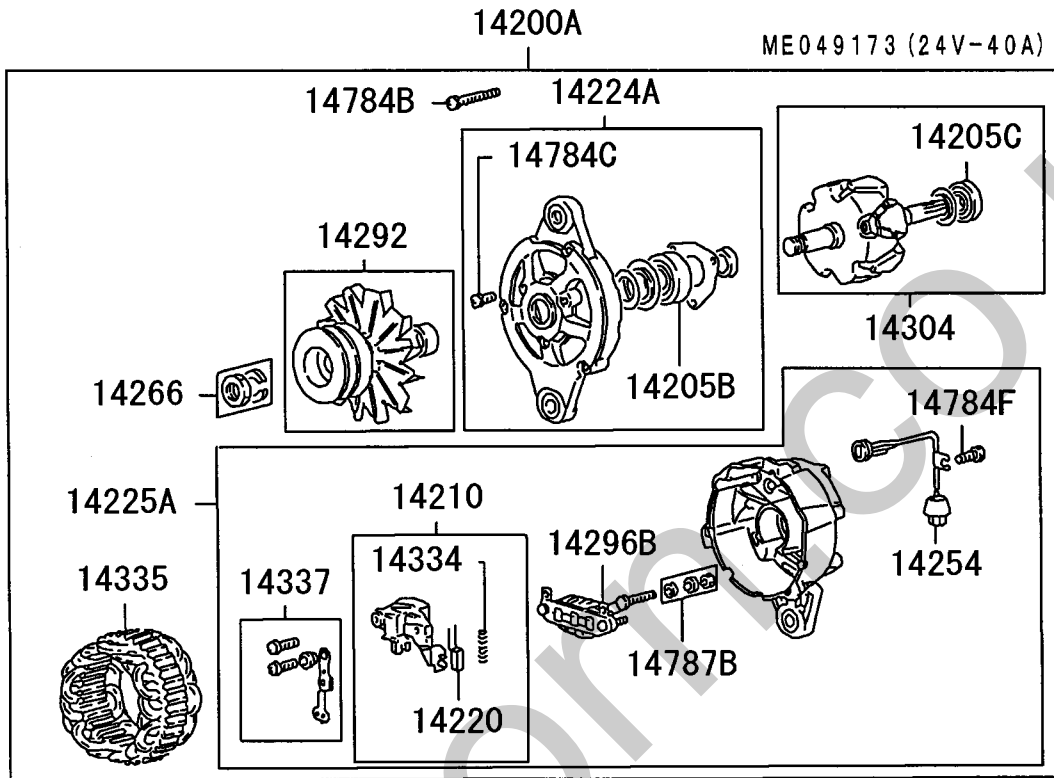

オルタネータ&レギュレータ
16-110 ALTERNATOR & REGULATOR

-156-

INNER PARTS

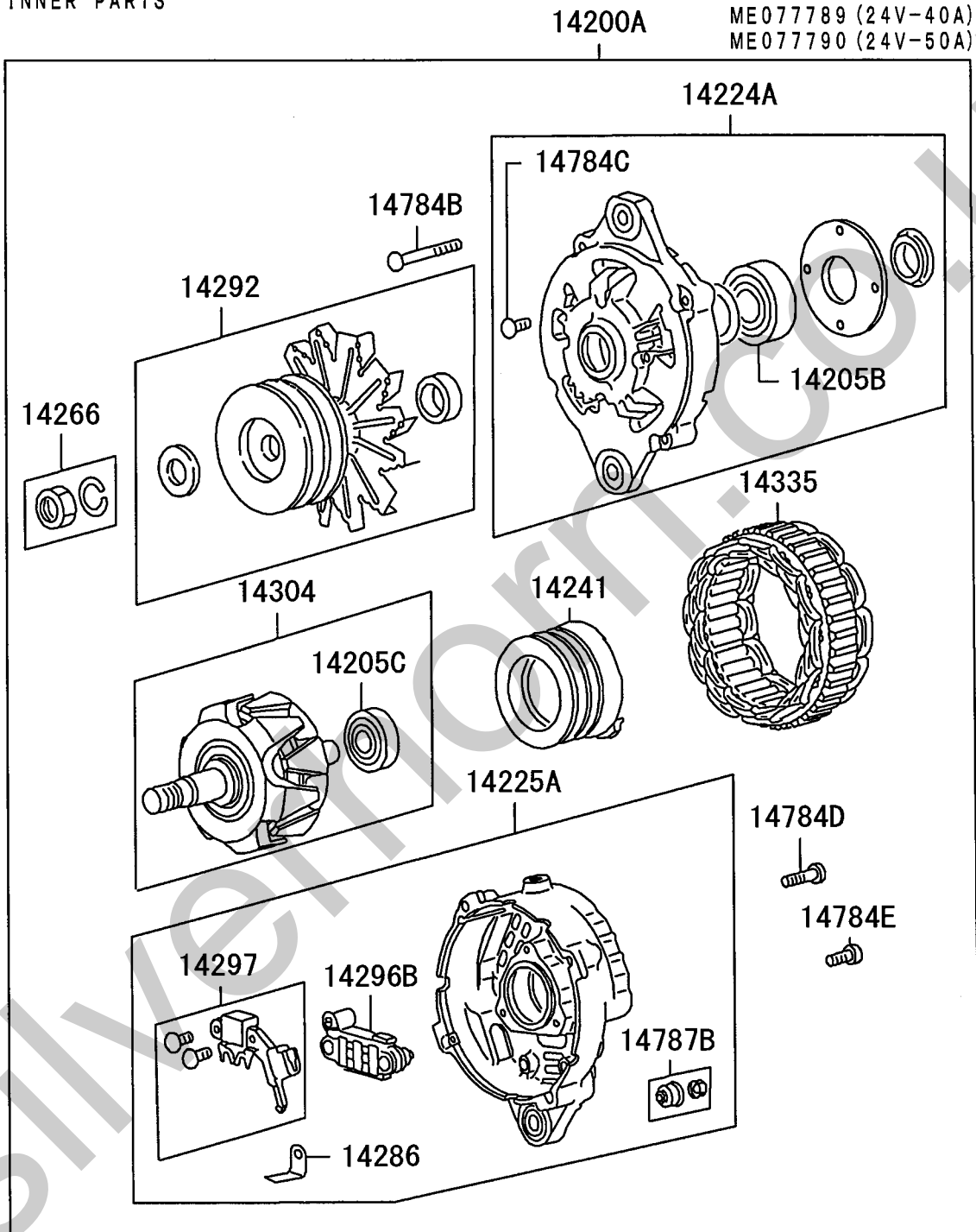

217T03

INNER PARTS

14200A

ME057822 (24V-60A)

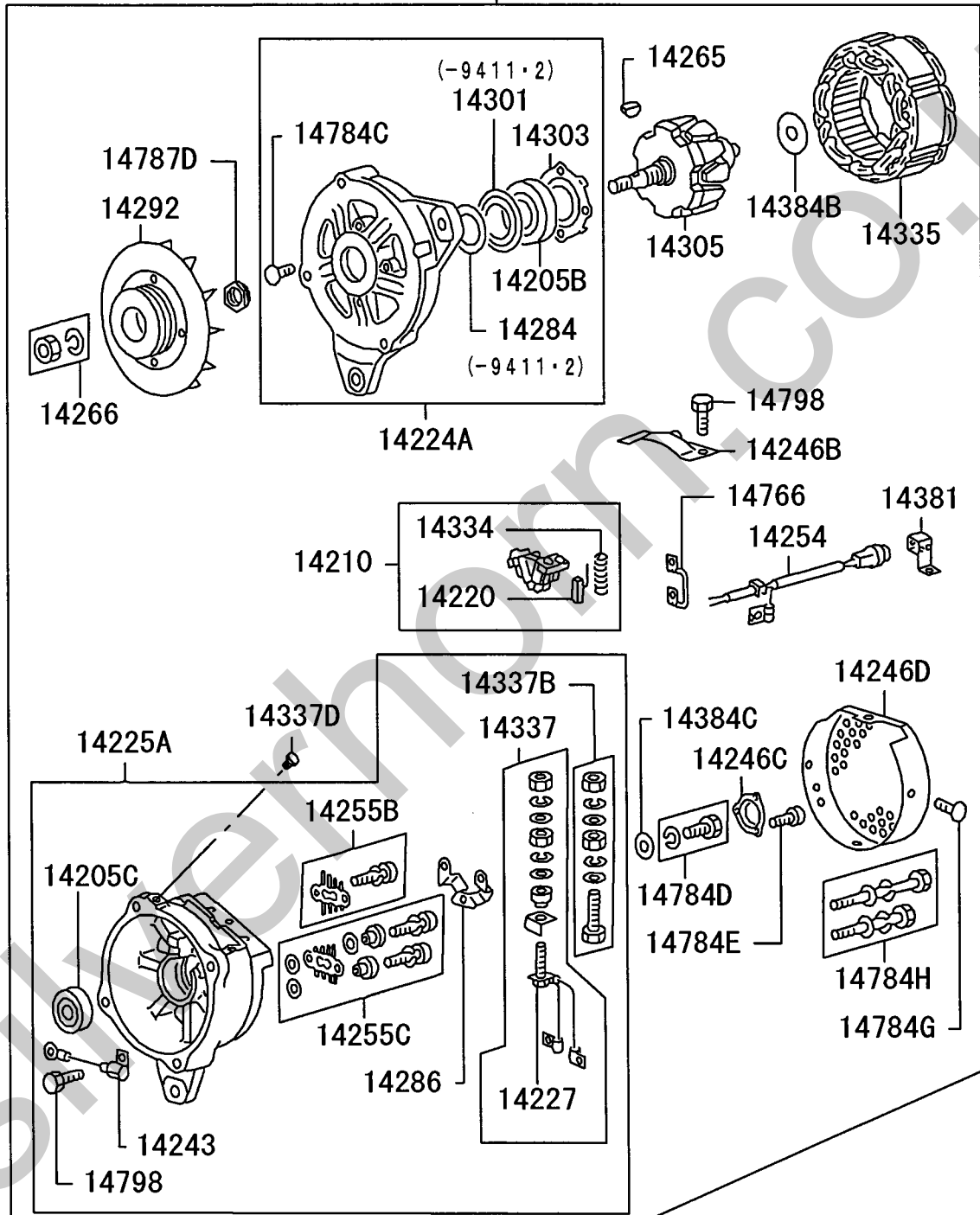

217T04

オルタネータ & レギュレータ
 16-110 ALTERNATOR & REGULATOR

-158-

INNER PARTS

14200A

ME077895 (24V-80A)

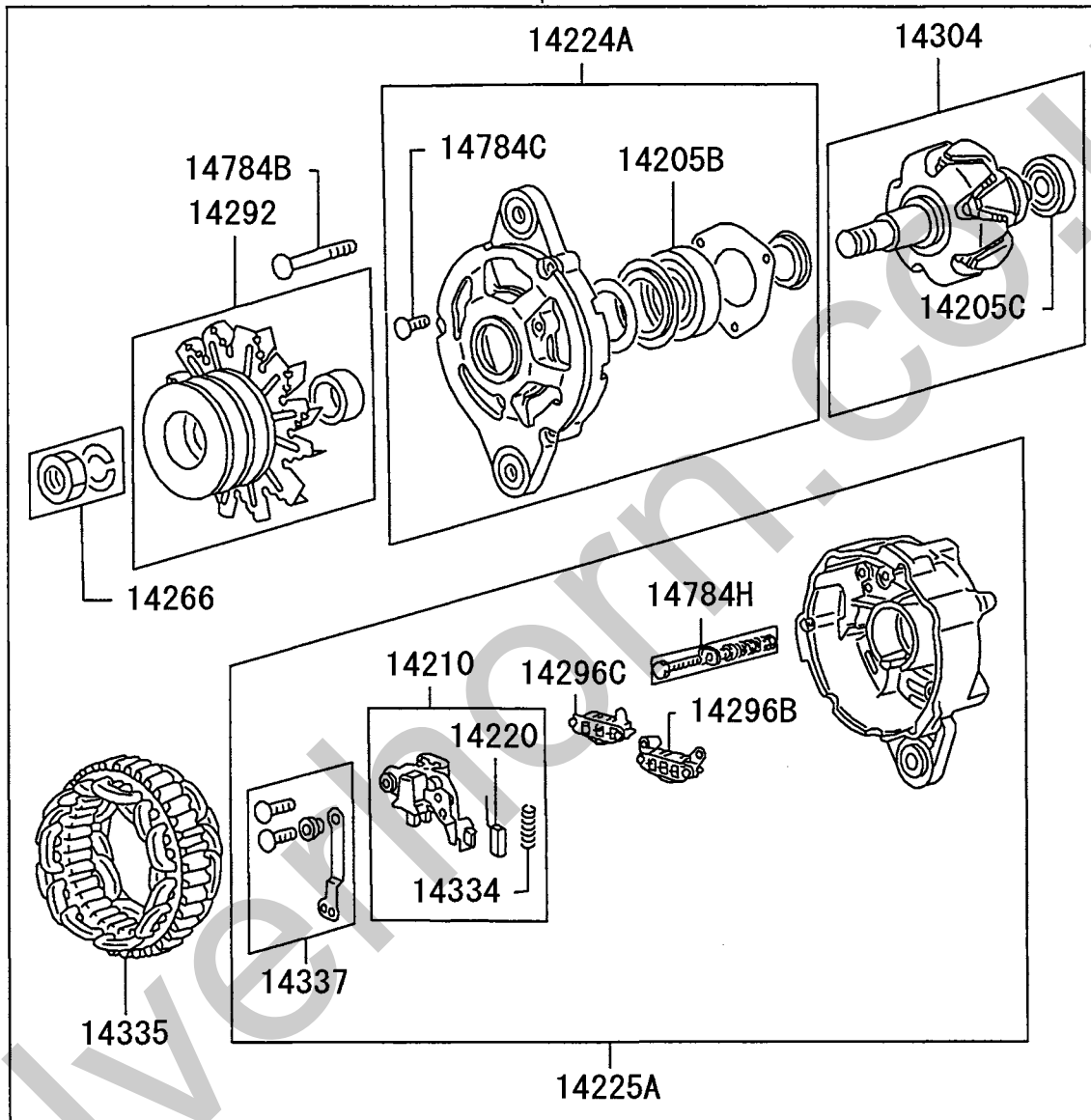

217T05

INNER PARTS

14200A

ME300073 (24V-80A)

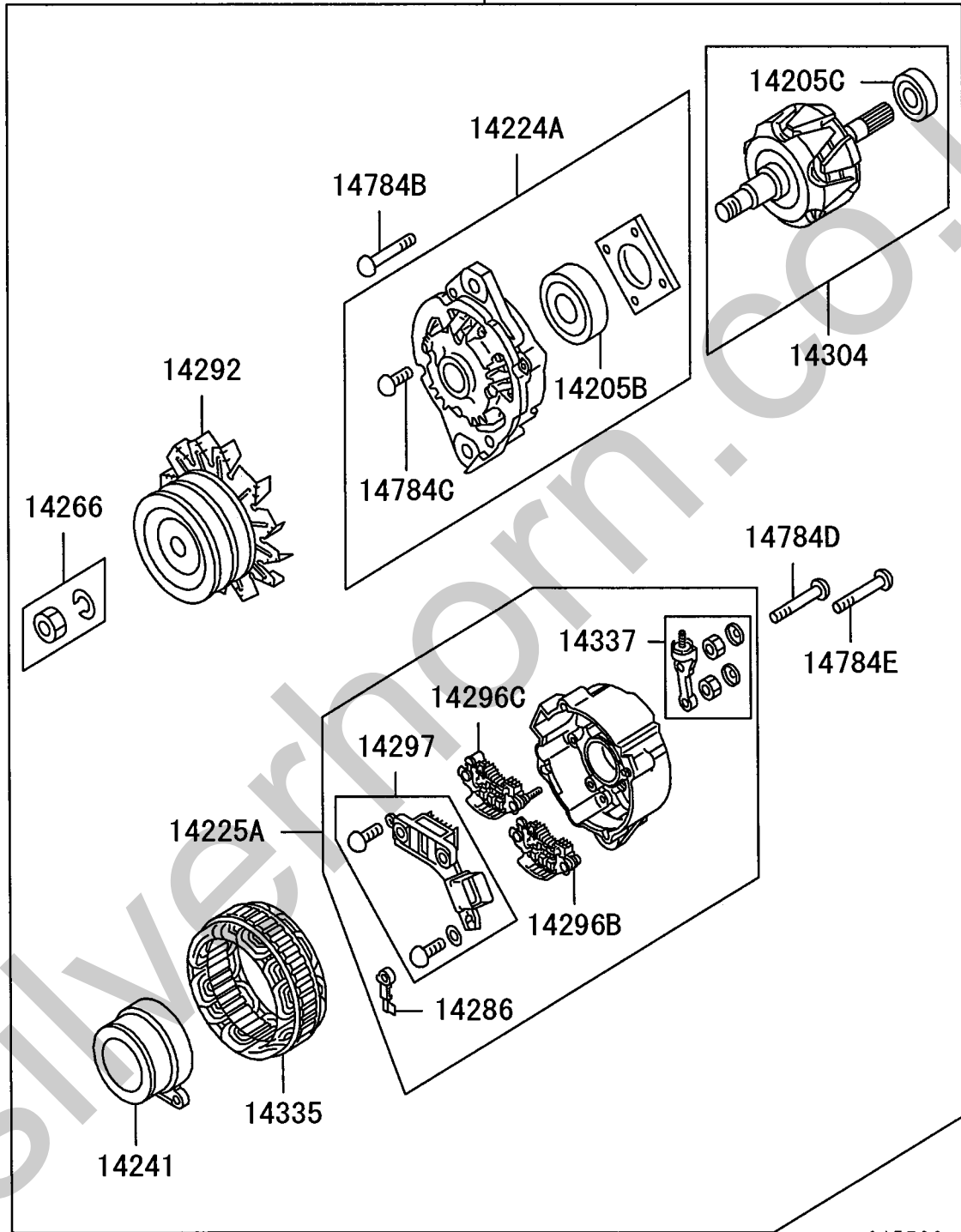

217T06

16 -110 ALTERNATOR & REGULATOR

04 6D240 CTJS04US1
 03 6D240 CTJS04000
 02 6D221 CTJS12131 COLD
 01 6D221 CTJS12000 STD

-160-

見出番号 REF.-NO.	部品番号 PART NO.	代 替 順 号 R / S C E N P O G	部品名称および記事・仕様記号 PART NAME & DESCRIPTION	型式・個数 MODEL & QTY					適用号機 APPLICABLE SERIAL NO.		管 区 M / R	新 規 V R D	
				0	1	2	3	4	FROM@	@UPTO			
14200A	A004T57986		ALTERNATOR ASSY 24V-40A	1						9006-1	9708-2		
	A004T65773		ALTERNATOR ASSY 24V-60A		1					9006-1	9708-2		
	A004T40286	3	ALTERNATOR ASSY 24V-40A	1						9708-3	9806-3		
	(A004T40386) A006T76086		ALTERNATOR ASSY 24V-80A		1					9708-3	0102-1		
	A004T40386		ALTERNATOR ASSY 24V-50A	1						9807-1			
	A004TU6084		ALTERNATOR ASSY 24V-80A		1					0102-2			
	A004T40386		ALTERNATOR ASSY 24V-50A			1	1			9901-1			
14205B	S930P37170		BEARING,ALTERNATOR ROTOR		1					9006-1	9708-2		
	S930P37201		BEARING,ALTERNATOR ROTOR	1						9006-1	9708-2		
	S930P37201		BEARING,ALTERNATOR ROTOR		1					9708-3	0102-1		
	S930P90670		BEARING,ALTERNATOR ROTOR	1						9708-3			
	S930P90670		BEARING,ALTERNATOR ROTOR		1					0102-2			
14205C	S930P90670		BEARING,ALTERNATOR ROTOR			1	1			9901-1			
	S930P34070		BEARING,ALTERNATOR ROTOR		1					9006-1	9411-2		
	B930P35670		BEARING,ALTERNATOR ROTOR	1						9006-1	9708-2		
	S930P34270		BEARING,ALTERNATOR ROTOR		1					9411-3	9708-2		
	S930P80870		BEARING,ALTERNATOR ROTOR		1					9708-3	0102-1		
	S930P81170		BEARING,ALTERNATOR ROTOR	1						9708-3			
	S930P81170		BEARING,ALTERNATOR ROTOR		1					0102-2			
14210	A649X08671		BRUSH KIT,ALTERNATOR		1		1			9901-1			
	A866T06670		BRUSH KIT,ALTERNATOR	1						9006-1	9708-2		
	A866T06670		BRUSH KIT,ALTERNATOR		1					9708-3	0102-1		
14216	3096801400		BRACE,ALTERNATOR ADJUSTING		1					9006-1	9708-2		
	ME057675		BRACE,ALTERNATOR ADJUSTING	1						9006-1	9812-3		
	ME057675		BRACE,ALTERNATOR ADJUSTING		1					9708-3	9812-3		
	ME057675		BRACE,ALTERNATOR ADJUSTING	1	1	1	1			9901-1			
14220	A648D02371		BRUSH,ALTERNATOR		2					9006-1	9708-2		
	A648D01971		BRUSH,ALTERNATOR	2						9006-1	9708-2		
	A648D01971		BRUSH,ALTERNATOR		2					9708-3	0102-1		
14223	3096802300		BRACKET,ALTERNATOR MOUNTING		1					9006-1	9708-2		
	ME057862		BRACKET,ALTERNATOR MOUNTING	1						9006-1	9812-3		
	ME057862		BRACKET,ALTERNATOR MOUNTING		1					9708-3	9812-3		
14224A	ME057862		BRACKET,ALTERNATOR MOUNTING	1	1	1	1			9901-1			
	A640T26770		BRACKET ASSY,ALTERNATOR,FR		1					9006-1	9708-2		
	A640T30770		BRACKET ASSY,ALTERNATOR,FR	1						9006-1	9708-2		
	A640T31170		BRACKET ASSY,ALTERNATOR,FR		1					9708-3	0102-1		
	A640X57570		BRACKET ASSY,ALTERNATOR,FR	1						9708-3			
14225A	A640X57570		BRACKET ASSY,ALTERNATOR,FR		1					0102-2			
	A640X57570		BRACKET ASSY,ALTERNATOR,FR			1	1			9901-1			
	A641T32871		BRACKET ASSY,ALTERNATOR,RR		1					9006-1	9708-2		
	A641T54670		BRACKET ASSY,ALTERNATOR,RR	1					9006-1	9708-2			

16-110 ALTERNATOR & REGULATOR

16-110 ALTERNATOR & REGULATOR

04 6D240 CTJS04US1
 03 6D240 CTJS04000
 02 6D221 CTJS12131 COLD
 01 6D221 CTJS12000 STD

-161-

見出番号 REF.-NO.	部品番号 PART NO.	代 替 R / P SC EN OG	部品名称および記事・仕様記号 PART NAME & DESCRIPTION	型式・個数 MODEL & QTY					適用号機 APPLICABLE SERIAL NO.		管 区 M / R	新 規 V R D	
				0	1	2	3	4	FROM@	@UPTO			
				0	1	2	3	4					
	A642X22670		BRACKET ASSY,ALTERNATOR,RR	1						9708-3	9806-3		
	A642X33070		BRACKET ASSY,ALTERNATOR,RR		1					9708-3	0102-1		
	A642X22770		BRACKET ASSY,ALTERNATOR,RR	1						9807-1			
	A642XC3270		BRACKET ASSY,ALTERNATOR,RR		1					0102-2			
	A642X22770		BRACKET ASSY,ALTERNATOR,RR				1	1		9901-1			
14227	A832D13571		CABLE & TERMINAL,ALTERNATOR		1					9006-1	9708-2		
14241	A299X01470		COIL,ALTERNATOR ROTOR	1						9708-3			
	A299X02670		COIL,ALTERNATOR ROTOR		1					0102-2			
	A299X01470		COIL,ALTERNATOR ROTOR				1	1		9901-1			
14243	A315D02271		CONDENSER,ALTERNATOR	1						9006-1	9708-2		
14246B	A212C10201		COVER,ALTERNATOR RR BRACKET	1						9006-1	9708-2		
14246C	A212D10001		COVER,ALTERNATOR RR BRACKET	1						9006-1	9708-2		
14246D	A212C10101		COVER,ALTERNATOR RR BRACKET	1						9006-1	9708-2		
14254	A309D10071		HARNESS,ALTERNATOR INR	1						9006-1	9708-2		
	A309D11271		HARNESS,ALTERNATOR INR	1						9006-1	9708-2		
14255B	A600X38771		HEAT SINK KIT,ALTERNATOR MINUS (-)	1						9006-1	9708-2		
14255C	A600X12671		HEAT SINK KIT,ALTERNATOR MINUS (+)	1						9006-1	9708-2		
14265	S275S04160		KEY,ALTERNATOR ROTOR SHAFT PULLEY	1						9006-1	9708-2		
14266	A529X09371		NUT KIT,ALTERNATOR PULLEY	1						9006-1	9708-2		
	A529X06571	3	NUT KIT,ALTERNATOR PULLEY W/WASHER	1						9006-1	9812-3		
	(A981X21071) A529X06571	3	NUT KIT,ALTERNATOR PULLEY W/WASHER		1					9708-3	9812-3		
	(A981X21071) A529X06571	3	NUT KIT,ALTERNATOR PULLEY W/WASHER	1	1					9901-1	0207-3		
	(A981X21071) A981X21071		NUT KIT,ALTERNATOR PULLEY FLANGE	1	1					0208-1			
	A529X06571	3	NUT KIT,ALTERNATOR PULLEY W/WASHER				1	1		9901-1	0207-3		
	(A981X21071) A981X21071		NUT KIT,ALTERNATOR PULLEY FLANGE				1	1		0208-1			
14284	A578D03301		GASKET,ALTERNATOR FR BRACKET		1					9006-1	9411-2		
14286	A666D03201		PLATE,ALTERNATOR RR BRACKET		1					9006-1	9708-2		
	A666X82570		PLATE,ALTERNATOR RR BRACKET	1						9708-3	9708-3		
	A666X82870		PLATE,ALTERNATOR RR BRACKET	1						9709-1			
	A666X83170		PLATE,ALTERNATOR RR BRACKET		1					0102-2			
	A666X82870		PLATE,ALTERNATOR RR BRACKET				1	1		9901-1			
14292	A628T43970		PULLEY & FAN KIT,ALTERNATOR		1					9006-1	9708-2		
	A628T48270		PULLEY & FAN KIT,ALTERNATOR	1						9006-1	9708-2		
	A628T48370		PULLEY & FAN KIT,ALTERNATOR		1					9708-3	0102-1		
	A628T54470		PULLEY & FAN KIT,ALTERNATOR	1						9708-3			
	A628X70670		PULLEY & FAN KIT,ALTERNATOR		1					0102-2			
	A628T54470		PULLEY & FAN KIT,ALTERNATOR				1	1		9901-1			
14296B	A860T22470		RECTIFIER,ALTERNATOR	1						9006-1	9708-2		

16-110 ALTERNATOR & REGULATOR

04 6D240 CTJS04US1
 03 6D240 CTJS04000
 02 6D221 CTJS12131 COLD
 01 6D221 CTJS12000 STD

-162-

見出番号 REF.-NO.	部品番号 PART NO.	代 替 R / P	変 更 順 号 S C E N E Q G	部品名称および記事・仕様記号 PART NAME & DESCRIPTION	型式・個数 MODEL & QTY					適用号機 APPLICABLE SERIAL NO.		管 区 M / R	新 規 V / R D	
					0	1	2	0	3	0	4			FROM@
14296C	A860X47870			RECTIFIER,ALTERNATOR	1						9708-3	9806-3		
	A860T16270			RECTIFIER,ALTERNATOR		1					9708-3	0102-1		
	A860X47970			RECTIFIER,ALTERNATOR	1						9807-1			
	A860X80370			RECTIFIER,ALTERNATOR			1				0102-2			
	A860X47970			RECTIFIER,ALTERNATOR				1	1		9901-1			
14297	A860T21370			RECTIFIER,ALTERNATOR		1					9708-3	0102-1		
	A860X83870			RECTIFIER,ALTERNATOR		1					0102-2			
14301	ME057592 (ME152118)	3		REGULATOR,ALTERNATOR		1					9006-1	9708-2		
	A866X38272			REGULATOR,ALTERNATOR	1						9708-3			
	A866X38272			REGULATOR,ALTERNATOR		1					0102-2			
14303	A834D05801			RETAINER,ALTERNATOR FR BEARING				1	1		9901-1			
	A835D00571			RETAINER,ALTERNATOR FR BEARING,RR				1			9006-1	9411-2		
14304	A834X06071			RETAINER,ALTERNATOR FR BEARING,RR				1			9411-3	9708-2		
	A860T30070			ROTOR KIT,ALTERNATOR	1						9006-1	9708-2		
	A880T31670			ROTOR KIT,ALTERNATOR		1					9708-3	0102-1		
	A880X69170			ROTOR KIT,ALTERNATOR	1						9708-3			
	A880X95070			ROTOR KIT,ALTERNATOR				1			0102-2			
14305	A880X69170			ROTOR KIT,ALTERNATOR					1	1	9901-1			
	A882T29470			ROTOR,ALTERNATOR		1					9006-1	9708-2		
14334	A389D01901			SPRING,ALTERNATOR BRUSH	2	2					9006-1	9610-1		
	A389D01901			SPRING,ALTERNATOR BRUSH	2						9610-2	9708-2		
	A389D01901			SPRING,ALTERNATOR BRUSH				2			9610-2	0102-1		
14335	A383T19271			STATOR,ALTERNATOR				1			9006-1	9708-2		
	A383T26070			STATOR,ALTERNATOR	1						9006-1	9708-2		
	A383X36270			STATOR,ALTERNATOR	1						9708-3	9806-3		
	A383T26870			STATOR,ALTERNATOR				1			9708-3	0102-1		
	A383X37370			STATOR,ALTERNATOR	1						9807-1			
	A383X59070			STATOR,ALTERNATOR				1			0102-2			
	A383X37370			STATOR,ALTERNATOR					1	1	9901-1			
	A450X10871			TERMINAL KIT,ALTERNATOR		1					9006-1	9708-2		
14337	A450X14571			TERMINAL KIT,ALTERNATOR	1						9006-1	9708-2		
	A450X14871			TERMINAL KIT,ALTERNATOR				1			9708-3	0102-1		
	A450X27371			TERMINAL KIT,ALTERNATOR				1			0102-2			
	A450X10971			TERMINAL KIT,ALTERNATOR		1					9006-1	9708-2		
14337B	A450X10971				1					9006-1	9708-2			
14337D	A450X15171			TERMINAL KIT,ALTERNATOR		1				9006-1	9708-2			
14381	A253D04201			CLAMP,ALTERNATOR				1			9006-1	9708-2		
14384	F250005000			WASHER,ALTERNATOR PLAIN,5	1	1					9006-1	9708-2		
	F251505000			WASHER,ALTERNATOR SPRING,5	1	1					9006-1	9708-2		
14384B	A406S01605			WASHER,ALTERNATOR	1	1					9006-1	9708-2		
14384C	A982S30523			WASHER,ALTERNATOR	1	1					9006-1	9708-2		
14384D	F251514000			WASHER,ALTERNATOR	1	1					9006-1	9708-2		
	MH005032			SPRING,14										
14384F	MH005032			WASHER,ALTERNATOR PLAIN,10.5	1	1					9006-1	9708-2		
14384G	3006813700			WASHER,ALTERNATOR PLAIN,15	1	1					9006-1	9708-2		

16 -110 ALTERNATOR & REGULATOR

オルタナタ & レギュレタ

04 6D240 CTJS04US1
 03 6D240 CTJS04000
 02 6D221 CTJS12131 COLD
 01 6D221 CTJS12000 STD

-163-

見出番号 REF.-NO.	部品番号 PART NO.	代 替 順 号 R / S C E N / P Q G	部品名称および記事・仕様記号 PART NAME & DESCRIPTION	型式・個数 MODEL & QTY					適用号機 APPLICABLE SERIAL NO.		管 区 M / R	新 規 V / R D	
				0	1	2	3	4	FROM@	@UPTO			
14766	A833X90270		WIRE,ALTERNATOR LEAD		1					9411-3	9708-2		
14782	3013302300		SPACER,ALTERNATOR 8	1						9006-1	9812-3		
	3013302300		SPACER,ALTERNATOR 8		1					9708-3	9812-3		
	3013302300		SPACER,ALTERNATOR 8	1	1	1	1			9901-1			
14782E	ME920043		SPACER,ALTERNATOR 20.4		1					9006-1	9708-2		
14784B	A414X18471		SCREW,ALTERNATOR INR	1						9006-1	9708-2		
	A414X10071		SCREW,ALTERNATOR INR		1					9708-3	0102-1		
	A414X10971		SCREW,ALTERNATOR INR	1						9708-3			
	A414X10971		SCREW,ALTERNATOR INR		1					0102-2			
14784C	A414X10971		SCREW,ALTERNATOR INR			1	1			9901-1			
	A414X15071		SCREW,ALTERNATOR INR		1					9006-1	9708-2		
	A414X10671		SCREW,ALTERNATOR INR	1						9006-1	9708-2		
	A414X10671		SCREW,ALTERNATOR INR		1					9708-3	0102-1		
	A414X20071		SCREW,ALTERNATOR INR	1						9708-3			
	A414X20071		SCREW,ALTERNATOR INR		1					0102-2			
	A414X20071		SCREW,ALTERNATOR INR				1	1		9901-1			
14784D	A715X00871		SCREW,ALTERNATOR INR		1					9006-1	9708-2		
	A414X21571		SCREW,ALTERNATOR INR	1						9708-3			
	A414X21571		SCREW,ALTERNATOR INR		1					0102-2			
	A414X21571		SCREW,ALTERNATOR INR				1	1		9901-1			
14784E	A414X16671		SCREW,ALTERNATOR INR		1					9006-1	9708-2		
	A414X23371		SCREW,ALTERNATOR INR	1						9708-3			
	A414X23371		SCREW,ALTERNATOR INR		1					0102-2			
	A414X23371		SCREW,ALTERNATOR INR				1	1		9901-1			
14784F	A981S60102		SCREW,ALTERNATOR INR	1						9006-1	9708-2		
14784G	A414X16771		SCREW,ALTERNATOR INR		1					9006-1	9708-2		
14784H	A715X00971		SCREW,ALTERNATOR INR		1					9006-1	9708-2		
	A414X23671		SCREW,ALTERNATOR INR		1					9708-3	0102-1		
14787B	A529X05571		NUT,ALTERNATOR INR	1						9006-1	9708-2		
	A529X08971	3	NUT,ALTERNATOR INR	1						9708-3	0110-3		
	(A529X12671)												
	A529X12671		NUT,ALTERNATOR INR	1						0111-1			
	A529X08971	3	NUT,ALTERNATOR INR				1	1		9901-1	0110-3		
	(A529X12671)												
	A529X12671		NUT,ALTERNATOR INR				1	1		0111-1			
14787D	A981S20206		NUT,ALTERNATOR INR		1					9006-1	9708-2		
14788	F230005000		NUT,ALTERNATOR 5	1	1					9006-1	9708-2		
	MS446183		NUT,ALTERNATOR FLANGE,8	1	1					9708-3			
	MS446183		NUT,ALTERNATOR FLANGE,8				1	1		9901-1			
14788B	MF434106		NUT,ALTERNATOR FLANGE,12	1	1	1	1			9006-1			
14798	S183S05104		BOLT,ALTERNATOR INR	3	3					9006-1	9708-2		
14799B	MH000183		BOLT,ALTERNATOR	1	1					9006-1	9708-2		

16 -110 ALTERNATOR & REGULATOR

04 6D240 CTJS04US1
 03 6D240 CTJS04000
 02 6D221 CTJS12131 COLD
 01 6D221 CTJS12000 STD

-164-

見出番号 REF.-NO.	部品番号 PART NO.	代 替 R / P	変 更 順 号 S C E N Q G	部品名称および記事・仕様記号 PART NAME & DESCRIPTION	型式・個数 MODEL & QTY						適用号機 APPLICABLE SERIAL NO.		管 区 M / R	新 規 V / R D
					0	1	2	3	4		FROM@	@UPTO		
	MH000703			12X168 BOLT,ALTERNATOR	1	1						9006-1		
	MH000703			FLANGE,12X125 BOLT,ALTERNATOR			1	1				9901-1		
	MH000703			FLANGE,12X125										
14799C	MH000713	#		BOLT,ALTERNATOR	1	1						9006-1	9708-2	
	MH000714			FLANGE,10X20 T02406A BOLT,ALTERNATOR	1	1						9006-1		
	MH000714			FLANGE,10X25 BOLT,ALTERNATOR			1	1				9901-1		
	MH000714			FLANGE,10X25										
14799D	F102514050			BOLT,ALTERNATOR	1	1						9006-1	9708-2	
	MH000372			14X50 BOLT,ALTERNATOR	1	1						9006-1		
	MH000372			WASHER ASSEMBLED,12X30 BOLT,ALTERNATOR			1	1				9901-1		
	MH000372			WASHER ASSEMBLED,12X30										
14799E	MH000713	#		BOLT,ALTERNATOR	4	4						9006-1	0312-3	
	MS146005			FLANGE,10X20 T02406A BOLT,ALTERNATOR	4	4						0401-1		V
	MH000713	#		FLANGE,10X22 BOLT,ALTERNATOR			4	4				9901-1	0312-3	
	MS146005			FLANGE,10X20 T02406A BOLT,ALTERNATOR			4	4				0401-1		V
	MS146005			FLANGE,10X22										
14799F	MF300845			BOLT,ALTERNATOR	1	1						9006-1	9708-2	
	MF300845			WASHER ASSEMBLED,10X30										

パワー・ステアリング オイルポンプ
37-110 POWER STEERING OIL PUMP

-166-

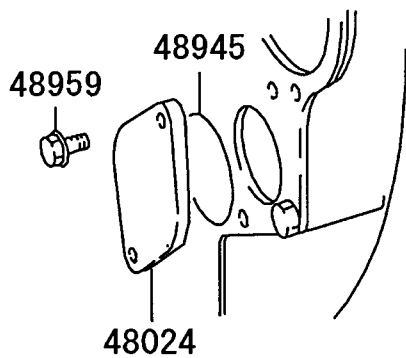

217T01

01911C

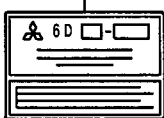

01911F

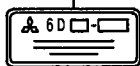

01913B



プレート & ラベル
42 -550 PLATE & LABEL

04 6D240 CTJS04US1
03 6D240 CTJS04000
02 6D221 CTJS12131 COLD
01 6D221 CTJS12000 STD

-169-

見出番号 REF.-NO.	部品番号 PART NO.	代 替 順 号 R I S C E N P O G	部品名称および記事・仕様記号 PART NAME & DESCRIPTION	型式・個数 MODEL & QTY					適用号機 APPLICABLE SERIAL NO.		管 区 M / R	新 規 V R D	
				0	1	2	3	4	FROM@-	@UPTO			
01911C	ME159054		NAME PLATE,ENG	1	1					9912-1	0212-3		
01911F	ME442139		NAME PLATE,ENG	1	1					0301-1			
	*		NAME PLATE,ENG NS			2				9901-1	0001-3		
	*		NAME PLATE,ENG NS				2			9901-1			
	*		NAME PLATE,ENG NS				2			0002-1	0304-3		
01913B	ME059915		PLATE,VALVE CLEARANCE CAUTION	1	1					9006-1	9308-3		
	ME157887		PLATE,VALVE CLEARANCE CAUTION	1	1					9309-1	9911-3		
	ME158858		PLATE,VALVE CLEARANCE CAUTION			1				9901-1	0304-3		
	ME158858		PLATE,VALVE CLEARANCE CAUTION				1			9901-1			

54 -730 シャシハーネスエキイブメント CHASSIS HARNESS EQUIPMENT

-170-

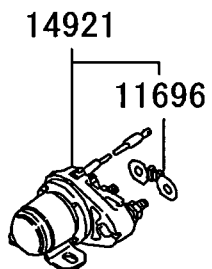

Silverhorn.CO.UK

部 品 番 号 顺 索 引

PARTS NUMBER INDEX

Silverhorn.CO.UK

Silverhorn.CO.UK

部 品 番 号 順 索 引
PARTS NUMBER INDEX

A1

部品番号 PART NO.	ページ PAGE	見出番号 REF.NO.	部品番号 PART NO.	ページ PAGE	見出番号 REF.NO.	部品番号 PART NO.	ページ PAGE	見出番号 REF.NO.
A004T40286	160	14200A	A641T54670	160	14225A	F251508000	103	07277BB
A004T40386	160	14200A	A642X22670	161	14225A	F251510000	51	15172D
A004T57986	160	14200A	A642X22770	161	14225A		70	04378E
A004T65773	160	14200A	A642X33070	161	14225A	F251514000	127	05466
A004TU6084	160	14200A	A642XC3270	161	14225A		162	14384D
A006T76086	160	14200A	A648D01971	160	14220	F287005019	40	03196
A212C10101	161	14246D	A648D02371	160	14220		44	03297
A212C10201	161	14246B	A649X08671	160	14210	F287005022	52	15186
A212D10001	161	14246C	A666D03201	161	14286	F315001000	26	04999B
A253D04201	162	14381	A666X82570	161	14286	F315001100	26	04999
A299X01470	161	14241	A666X82870	161	14286	F315001800	71	04379C
A299X02670	161	14241	A666X83170	161	14286	F315307500	167	48945
A309D10071	161	14254	A715X00871	163	14784D	F315603000	71	04379F
A309D11271	161	14254	A715X00971	163	14784H	F315603500	44	03295B
A315D02271	161	14243	A832D13571	161	14227	F315604500	15	01983
A383T19271	162	14335	A833X90270	163	14766	F320206200	32	03795
A383T26070	162	14335	A834D05801	162	14301		130	10098B
A383T26870	162	14335	A834X06071	162	14303	F420210000	21	01399M
A383X36270	162	14335	A835D00571	162	14303		66	04184B
A383X37370	162	14335	A860T16270	162	14296B		77	04998C
A383X59070	162	14335	A860T21370	162	14296C		83	07307
A389D01901	162	14334	A860T22470	161	14296B		137	11414
A406S01605	162	14384B	A860T30070	162	14304		143	12784B
A414X06671	151	14185B	A860X47870	162	14296B	F420212000	77	04998B
A414X10071	163	14784B	A860X47970	162	14296B	F420214000	52	15189B
A414X10671	163	14784C	A860X80370	162	14296B		77	04998D
A414X10971	163	14784B	A860X83870	162	14296C	F420216000	30	02116
A414X15071	163	14784C	A866T06670	160	14210		52	15189C
A414X16671	163	14784E	A866X38272	162	14297		129	10021
A414X16771	163	14784G	A880T31670	162	14304		133	10191
A414X18471	163	14784B	A880X69170	162	14304	F420220000	66	04192
A414X20071	163	14784C	A880X95070	162	14304	F420227000	52	15189D
A414X21571	163	14784D	A882T29470	162	14305		57	01399C
A414X23371	163	14784E	A981S20206	163	14787D		77	04998B
A414X23671	163	14784H	A981S60102	163	14784F	F430003201	15	01988
A450X10871	162	14337	A981X21071	161	14266	F461012000	76	04996E
A450X10971	162	14337B	A982S30523	162	14384C	F461016000	53	15197E
A450X14571	162	14337	B930P35670	160	14205C	F500010000	66	04189
A450X14871	162	14337	DUMMY01	101	07264D	F501428000	20	01395J
A450X15171	162	14337D	F102505010	151	14199D	F800020000	62	04099
A450X27371	162	14337	F102506025	31	02192C	F800606205	129	10001B
A529X05571	163	14787B	F102508022	53	15198B	F801006305	129	10001
A529X06571	161	14266	F102514050	164	14799D	M0001300	30	02185D
A529X08971	163	14787B	F145010030	19	01383		130	10086
A529X09371	161	14266	F145012035	151	14192		133	10185
A529X12671	163	14787B	F160005010	151	14199D	M003T95082	149	14000A
A578D03301	161	14284	F230005000	163	14788	M009T60171	149	14000A
A600X12671	161	14255C	F230006000	30	02188	M106X40471	149	14001
A600X38771	161	14255B	F230010000	70	04377	M106X44371	149	14001
A628T43970	161	14292	F230016000	44	03296B	M106X44372	149	14001
A628T48270	161	14292	F230510000	40	03299	M135X02771	150	14038
A628T48370	161	14292	F230516000	44	03296B	M191T66171	150	14025
A628T54470	161	14292	F232014000	127	05471	M191X66571	150	14025
A628X70670	161	14292	F250005000	162	14384	M191X69571	150	14025
A640T26770	160	14224A	F250008000	30	02178C	M212D12801	150	14032
A640T30770	160	14224A	F250010000	70	04378C	M230X00971	150	14039
A640T31170	150	14068	F251505000	151	14191	M232X14071	150	14028A
	160	14224A		162	14384	M256X08471	151	14178
A640X57570	160	14224A	F251506000	30	02178	M314X02371	150	14056
A641T32871	160	14225A	F251508000	40	03264	M357X61571	150	14037A

部 品 番 号 顺 索 引
PARTS NUMBER INDEX

A2

部品番号 PART NO.	ページ PAGE	見出番号 REF.NO.	部品番号 PART NO.	ページ PAGE	見出番号 REF.NO.	部品番号 PART NO.	ページ PAGE	見出番号 REF.NO.
M357X67871	150	14037	ME051003	56	01307C	ME052672	30	02114
M357X92871	150	14024	ME051051	41	03323	ME052691	32	03797
M371X21571	151	14082B	ME051083	41	03412	ME052763	35	03010A
M371X83271	151	14082B	ME051120	17	03460	ME052765	35	03006
M385X05271	151	14077	ME051122	17	03470	ME052769	43	03155B
M385X06771	151	14077	ME051180	41	03316	ME052787	36	03060
M391C02201	150	14076	ME051208	41	03417	ME052788	36	03060
M391X04571	150	14076	ME051209	40	03100	ME052789	36	03060
M414X07472	151	14185B	ME051241	56	01307K	ME052790	36	03060
M578C22201	150	14034C	ME051300	17	03411	ME052802	43	03155C
M578D22601	150	14034	ME051344	56	01307D	ME052803	44	03298D
M578X30971	150	14068	ME051354	17	03407	ME052816	30	02100
M578X31071	150	14034B	ME051373	15	01127	ME052825	35	03010A
M605X77571	150	14054	ME051375	20	01388	ME052843	43	03107C
M605X98871	150	14054	ME051410	41	03405	ME052916	43	03118
M641X71472	149	14016	ME051515	17	01298B	ME052940	43	03135A
M641X83471	149	14016	ME051516	17	01298C	ME052942	43	03136
M642X36171	150	14017	ME051584	40	03266B	ME052962	44	03298E
M642X48171	150	14017	ME051618	17	01210	ME052996	43	03118
M644B20701	150	14017	ME051632	19	01342	ME053112	139	12010
M646B22301	149	14015	ME051633	19	01342	ME053862	139	12046
M646C71001	149	14013	ME051634	19	01342	ME053870	142	12781
M648C27071	150	14020	ME051635	56	01326	ME053946	139	12000
M648X42171	150	14020	ME051672	20	01396B	ME053950	139	12092
M649T07371	150	14044A	ME051673	20	01396C	ME053952	139	12092B
M649X21471	150	14044A	ME051674	20	01396D	ME054045	70	04353
M690X00171	149	14003	ME051675	20	01396E	ME054082	65	04127C
M690X00871	149	14003	ME051676	20	01396F	ME054110	70	04322
M800T44671	151	14086	ME051677	21	01396G	ME054156	65	04127B
M800X74071	151	14086	ME051678	21	01396H	ME054171	62	04045
M816D00701	150	14069	ME051694	15	01100	ME054232	76	04925D
M863C06671	150	14046	ME051696	41	03410	ME054238	65	04130
M863X08972	150	14046	ME051697	41	03420	ME054240	65	04100A
M863X09274	150	14046	ME051702	40	03277B	ME054279	77	12543
M863X10171	150	14046	ME051705	15	01182	ME054334	65	04180
M900X02071	151	14084	ME051706	19	01381	ME054372	62	04035
M901X02671	149	14011B	ME051712	19	01305	ME054373	62	04007A
M931X01270	149	14008C	ME051714	17	01210	ME054385	15	01303
M981X76071	149	14011	ME052053	21	03040	ME054393	62	04124
M982X38871	151	14084	ME052054	21	03040	ME054407	76	04925B
M986C10102	151	14185	ME052055	21	03040	ME054525	76	04925C
MB249338	171	11696	ME052056	21	03040	ME054545	76	04925C
MD000523	15	01134	ME052057	21	03040	ME054547	70	04300A
MD008784	25	04903A	ME052149	35	03036	ME054549	70	04311
MD132260	25	04903A	ME052488	35	03050	ME054661	65	04101
ME011910	15	01951	ME052489	35	03050	ME054669	70	04334
ME014717	71	04385	ME052490	35	03050	ME054703	62	04017
ME016894	79	05392	ME052491	36	03050	ME054744	57	01399E
ME031088	19	01385K	ME052492	36	03050		77	12537
	137	11475	ME052497	25	01510	ME055147	129	10013
	142	12731	ME052550	30	02174	ME055149	130	10098
ME032042	35	03031	ME052660	35	03016	ME055315	129	10041
ME034545	76	04232	ME052661	30	02122	ME055339	133	10151
ME034549	62	04095	ME052665	35	03037	ME055392	129	10016
ME039462	127	05429	ME052666	35	03037	ME055393	129	10044
ME040252	57	02200B	ME052667	35	03037	ME055395	129	10049B
ME049247	171	14921	ME052668	35	03037	ME055396	130	10096B
ME049300	150	14057B	ME052669	35	03037	ME055398	129	10025
ME050717	137	11431	ME052670	35	03037	ME055402	133	10122
ME050759	142	12563	ME052671	30	02114	ME056279	79	05314

部 品 番 号 顺 索 引
PARTS NUMBER INDEX

A3

部品番号 PART NO.	ページ PAGE	見出番号 REF.NO.	部品番号 PART NO.	ページ PAGE	見出番号 REF.NO.	部品番号 PART NO.	ページ PAGE	見出番号 REF.NO.
ME056323	127	07512	ME093522	52	15183	ME150639	62	04017
ME056381	83	07011	ME095645	41	03405	ME150682	70	04334
ME056670	79	05300	ME120129	43	03026	ME150689	43	03135A
ME056679	118	07429	ME120351	62	04000A	ME150855	133	10191B
ME056680	118	07429	ME120385	62	04005	ME150858	56	01326
ME056681	118	07429	ME120432	56	01307B	ME150866	70	04300A
ME056925	127	07512	ME120433	57	02023	ME150877	143	12784
ME057119	50	15026A	ME120978	133	10122	ME150878	149	11615
ME057309	167	48024	ME121284	62	04045	ME150883	133	10151
ME057329	149	11631	ME121781	35	03022	ME150921	70	04322
ME057592	162	14297	ME121787	65	04100A	ME151038	20	01388
ME057663	149	11615	ME121788	65	04140	ME151039	20	01388B
ME057675	160	14216	ME121789	65	04180	ME151085	30	02100
ME057741	149	11615	ME121799	35	03022	ME151190	37	03060
ME057862	160	14223	ME121800	65	04115	ME151191	37	03060
ME058037	31	03030A	ME131935	56	01306	ME151192	37	03060
ME058198	25	01500	ME133039	56	01306	ME151193	37	03060
ME058316	35	03047	ME150048	30	02114	ME151267	30	02111
ME058862	76	04925C	ME150049	30	02114	ME151298	43	03136
ME058894	15	01951	ME150050	25	01510	ME151299	40	03100
ME058900	25	04905	ME150051	137	11410	ME151300	40	03146
ME058934	25	04912	ME150056	57	01399	ME151450	35	03016
ME058961	77	12548	ME150057	57	01399B	ME151859	31	03030A
ME058983	77	12621B	ME150058	57	02023	ME151865	62	04161D
ME058989	15	01951	ME150060	26	04991B	ME151866	62	04161C
ME059050	77	12617	ME150063	62	04161B	ME151877	62	04005
ME059062	77	12617	ME150064	62	04161D	ME152008	40	03277B
ME059271	133	10134	ME150065	62	04161C	ME152118	162	14297
ME059413	133	10100	ME150067	149	11615	ME152225	30	02100
ME059420	133	10106	ME150068	149	11615	ME152344	25	01510
ME059508	127	05467	ME150073	139	12043	ME152473	56	01326
ME059592	127	07507	ME150173	50	15000A	ME152481	139	12000
ME059630	127	07512B	ME150236	51	15081	ME152584	30	02174
ME059915	169	01913B	ME150237	51	15076	ME152593	30	02174
ME060124	56	01361	ME150257	30	02100	ME152602	30	02100
ME060125	57	03033	ME150299	129	10049	ME152617	30	02100
ME061021	40	03172	ME150307	129	10043	ME153170	70	04322
ME061330	21	01397N	ME150316	30	02100	ME153172	70	04322
ME061398	41	03416	ME150342	50	15000A	ME153173	70	04346
ME061699	30	02124	ME150344	50	15000A	ME153215	19	01305
ME062323	43	03291B	ME150440	70	04322	ME153274	41	03440
ME062326	43	03145	ME150441	70	04311	ME153301	56	01394B
ME062523	17	01207B	ME150442	70	04377	ME153319	20	01388
ME062573	43	03271	ME150443	70	04346	ME157001	118	07429
ME062660	43	03129	ME150453	70	04300A	ME157002	118	07429
ME062828	32	03057	ME150482	19	01381	ME157003	118	07429
ME062905	43	03107B	ME150492	35	03010A	ME157004	118	07429
ME063680	145	13010	ME150493	35	03010A	ME157032	25	04912
ME063946	145	13085	ME150497	31	03030A	ME157053	129	10012
ME064526	70	04338	ME150506	43	03132A	ME157194	77	12548
ME067539	149	11610	ME150508	44	03298D	ME157205	51	15078
ME074455	76	04232	ME150509	44	03298E	ME157230	77	12621
ME084527	70	04353	ME150511	41	03302B	ME157250	137	11432
ME090010	79	05300A	ME150519	43	03155B	ME157453	118	07429
ME090012	79	05300A	ME150520	43	03155C	ME157454	118	07429
ME090430	30	02174	ME150532	62	04124	ME157709	118	07429
ME091034	43	03026	ME150541	62	04161B	ME157710	118	07429
ME091037	43	03132A	ME150600	50	15000A	ME157711	118	07429
ME091814	41	03440	ME150601	62	04000A	ME157712	118	07429
ME093097	43	03026	ME150637	62	04007A	ME157733	3	01010A

部 品 番 号 顺 索 引
PARTS NUMBER INDEX

A4

部品番号 PART NO.	ページ PAGE	見出番号 REF.NO.	部品番号 PART NO.	ページ PAGE	見出番号 REF.NO.	部品番号 PART NO.	ページ PAGE	見出番号 REF.NO.
ME157887	169	01913B	ME351469	31	03034	ME900767	129	10040
ME158019	127	05476	ME351471	32	03083	ME910348	80	07501N
ME158066	76	04925C	ME351483	62	04161C	ME910445	80	07501M
ME158097	35	03037	ME351484	21	01399K	ME920043	163	14782E
ME158098	35	03037	ME351744	40	03266B	ME930001	76	04973C
ME158099	35	03037	ME351837	32	03083		123	07495
ME158100	35	03037	ME352391	32	03083	ME930089	25	04985
ME158101	35	03037	ME352719	37	03787	ME930211	79	05482
ME158102	35	03037	ME353132	149	11615	ME930243	79	05482
ME158104	137	11431	ME442139	169	01911C	ME993082	11	03000A
ME158107	83	07034	ME713006	50	15001	ME993083	11	03000A
ME158178	25	01500	ME713008	52	15184C	ME993085	7	01300A
ME158181	25	04911	ME713009	51	15172B	ME993092	7	01300A
ME158183	79	05480N	ME713011	50	15074	ME993132	3	01010A
ME158184	79	05480M	ME713017	51	15106	ME993135	3	01010A
ME158221	119	07429	ME713019	51	15097	ME993287	13	01070
ME158222	118	07429	ME713020	50	15037	ME993457	9	01340
ME158223	118	07429	ME713021	51	15105	ME993459	3	01010A
ME158224	118	07429	ME713022	51	15117	ME993576	11	03000A
ME158225	119	07429	ME713031	50	15014	ME993779	7	01300A
ME158226	119	07429	ME713076	51	15172C	ME993783	7	01300A
ME158303	43	03129	ME713077	53	15198B	ME993816	11	03000A
ME158479	127	07507	ME713078	51	15098C	ME993817	3	01010A
ME158685	129	10044	ME713080	51	15098B	ME993820	3	01010A
ME158858	169	01913B	ME713082	52	15184D	ME995231	129	10000A
ME159054	169	01911C	ME713093	53	15198C	ME995285	129	10010
ME159062	77	12617	ME713114	51	15082	ME995477	36	03060
ME160705	62	04042	ME713196	52	15191	ME995478	36	03060
ME160708	62	04016	ME713206	50	15043A	ME995479	36	03060
ME160715	62	04033	ME713208	52	15174B	ME995480	36	03060
ME162632	62	04035	ME713224	50	15047	ME995487	9	01340
ME164716	65	04111B	ME713226	50	15023	ME995572	129	10010
ME164857	65	04130	ME713230	50	15045A	ME995622	3	01010A
ME180041	21	01397N	ME713281	50	15031	ME995768	7	01300A
ME180513	65	04100A	ME713327	51	15087	ME995775	7	01300A
ME180514	65	04180	ME713329	50	15034	ME996002	133	10110
ME181323	21	03040	ME713337	52	15183F	ME996003	133	10110
ME181324	21	03040	ME713361	51	15082	ME996148	11	03000A
ME181325	21	03040	ME713385	52	15179	ME996149	7	01300A
ME181326	21	03040	ME713419	50	15073	ME996339	11	03000A
ME181327	21	03040	ME713420	51	15095	ME996470	9	01340
ME181337	36	03050	ME713424	50	15045A	ME996492	7	01300A
ME181338	36	03050	ME737041	50	15031	ME996661	21	03040
ME181339	36	03050	ME737042	50	15045A	ME996662	21	03040
ME181340	36	03050	ME737118	50	15073	ME996663	21	03040
ME181341	36	03050	ME737121	50	15073	ME996665	21	03040
ME241056	129	10043	ME737123	51	15095	ME996849	129	10000A
ME350565	62	04007A	ME737125	51	15095	ME996916	5	01200A
ME350786	37	03060	ME737130	51	15116	ME997002	129	10010
ME350787	37	03060	ME737132	50	15024A	ME997037	7	01300A
ME350788	37	03060	ME737137	50	15031	ME997088	13	01070
ME350789	37	03060	ME737139	50	15031	ME997802	13	01070
ME350864	21	03040	ME737201	52	15184C	ME999368	11	03000A
ME350865	21	03040	ME737202	50	15074	ME999594	9	01340
ME350866	21	03040	ME737204	50	15073	ME999969	5	01200A
ME350867	21	03040	ME737214	50	15045A	MF140005	151	14199C
ME350868	22	03040	ME737215	50	15045A	MF140009	123	07499
ME351296	32	03057	ME900703	129	10040	MF140011	76	04997
ME351447	62	04161B	ME900708	129	10040	MF140013	76	04997B
ME351466	19	01385H	ME900715	129	10040		79	05496M

部 品 番 号 顺 索 引
PARTS NUMBER INDEX

A5

部品番号 PART NO.	ページ PAGE	見出番号 REF.NO.	部品番号 PART NO.	ページ PAGE	見出番号 REF.NO.	部品番号 PART NO.	ページ PAGE	見出番号 REF.NO.
MF140013	127	05477	MH000713	164	14799C	MH021015	26	04993
MF140020	149	11699C		164	14799E	MH021218	79	05494
MF140027	76	04997B	MH000714	40	03198	MH021233	76	04994
MF140213	76	04997B		71	04399		127	05474
	79	05496M		79	05399	MH021260	76	04994B
	127	05477		130	10088	MH021295	76	04992
MF240031	123	07499C		133	10198C	MH021370	143	12799B
MF240050	31	02192E		137	11424	MH021375	133	10193
MF241222	40	03277C		164	14799C	MH023119	76	04973B
MF241230	123	07499C	MH000715	62	04098		127	05467
MF241232	123	07499C		66	04199	MH023799	25	04985
MF243649	31	02192E		83	07347	MH035018	25	01521
MF300841	31	02192BB	MH000716	143	12797B	MH035025	65	04182
MF300843	63	04178C	MH000724	53	15199B	MH035044	71	04379C
MF300845	56	01397		83	07347C	MH035067	79	05394F
	164	14799F	MH000727	57	01397C	MH035069	79	05394E
MF300850	62	04096	MH000732	137	11424B	MH035077	21	01399N
	63	04178	MH000733	31	02199	MH035087	25	04991B
MF300853	63	04178	MH000740	71	04399D	MH035092	71	04379E
MF303363	25	01597B	MH000829	143	12797		129	10071C
MF303365	56	01397	MH000840	151	14199B	MH035093	70	04379
MF406251	76	04972	MH000843	167	48959	MH035129	76	04978
MF406285	133	10183	MH000922	37	03775	MH035135	40	03279
MF407728	139	12089		53	15199DE	MH035157	17	01291
MF434103	76	04979	MH000923	151	14199B	MH035160	52	15189E
	149	11682	MH000924	151	14199B	MH035161	52	15189F
MF434105	129	10084	MH000925	31	02192F	MH035164	79	05394F
	133	10187	MH000927	30	02192	MH035166	79	05394E
MF434106	151	14195B	MH000931	25	01597B	MH035190	52	15189E
	163	14788B	MH000999	25	04956B	MH035192	52	15189F
MF472086	62	04078		53	15199DC	MH035225	26	04999
MF472402	44	03294		79	05496M	MH035236	71	04379
MF472404	20	01387K		151	14199C	MH035242	26	04999
MF472405	19	01387H	MH001103	15	01198	MH035606	52	15183
	32	03796	MH001785	25	01597B	MH035618	134	10199
MF472406	20	01387J	MH002131	17	01282B	MH035619	129	10071
MF472407	37	03788	MH002154	139	12089	MH035620	129	10077
MF472585	17	01288	MH004054	139	12096	MH035622	129	10071B
MF476220	52	15186	MH004069	62	04079	MH035626	71	04379F
MF540021	62	04099	MH004074	44	03296E	MH037084	79	05392
MF650106	53	15197B	MH004075	44	03296D	MH037087	53	15197F
MH000183	163	14799B	MH004110	142	12779B		76	04996C
MH000372	164	14799D	MH004186	151	14195		79	05398
MH000377	37	03787	MH005003	151	14191B	MH037116	79	05491B
MH000392	139	12099	MH005032	162	14384F	MH037117	71	04385
MH000657	123	07494	MH007008	20	01387N	MH037126	25	01598D
MH000703	164	14799B	MH007009	20	01387M	MH037137	19	01385M
MH000706	15	01978	MH007011	20	01387HC	MH037279	76	04996B
	53	15199D	MH012026	37	03788B		83	07346
	57	01397D	MH012037	19	01386M	MH037453	52	15192E
	80	05496P		44	03293B	MH037507	52	15192D
	123	07499B	MH014510	129	10040	MH037716	76	04996D
	130	10088D	MH020258	123	07498B	MH037723	56	01385
MH000707	71	04399	MH020259	123	07498C	MH037725	19	01385J
MH000708	133	10198B	MH020290	53	15194B	MH037760	25	01395Z
MH000709	71	04399C	MH020293	123	07498F	MH037762	17	01287B
MH000713	25	04956D	MH020294	123	07498G	MH037788	19	01385J
	53	15199C	MH020380	133	10193		57	04296
	56	01397B	MH020558	53	15194C	MH038358	56	01392
	76	04997C	MH020807	79	05493	MH038906	76	04987

部 品 番 号 顺 索 引
PARTS NUMBER INDEX

A6

部品番号 PART NO.	ページ PAGE	見出番号 REF.NO.	部品番号 PART NO.	ページ PAGE	見出番号 REF.NO.	部品番号 PART NO.	ページ PAGE	見出番号 REF.NO.
MH038906	127	05472	0130206040	100	07243B	0292010160	100	07243J
MH038913	52	15192B	0130208040	100	07243BC	0292012130	100	07243H
MH039033	58	04298		100	07243F	0292016010	100	07243G
MH039406	58	04298	0130210040	85	07125C	0292016150	100	07243H
MH039564	58	04298	0130305240	100	07243GD	0292312030	100	07243D
MH040026	31	03035	0141105440	104	07277GD	0292406010	100	07243J
MH093016	25	04911	0141106440	103	07277	0293005070	118	07406C
MS146002	80	05496P		104	07277GB	0293012250	109	07387B
MS146003	25	01597B		104	07277J	0293020140	92	07156C
	53	15199C	0141110440	113	07185C	0293105170	103	07277F
	53	15199D	0145306540	92	07156D	0293106130	103	07264JC
MS146004	25	04956D	0160100540	103	07267F	0293108020	103	07277G
	56	01397B	0160100640	103	07267JC	0293108040	101	07264C
	57	01397D	0160100710	103	07267C	0293108050	101	07264C
	77	04997C	0160100740	103	07267C	0293108520	108	07383B
MS146005	164	14799E		103	07267G	0293108530	108	07383B
MS146006	71	04399	0160100840	103	07267H	0293108540	109	07383B
	79	05399	0160101640	103	07267B	0293108550	109	07383B
	133	10198C	0166502230	85	07102C	0293108560	109	07383B
MS146008	71	04399	0200061240	85	07104D	0293108610	103	07264JB
MS146010	66	04199	0200061640	98	07207BE	0293108620	103	07264JB
MS146014	71	04399D		98	07207D	0293108630	103	07264JB
	133	10198B	0200064540	98	07207J	0293108650	103	07264JB
MS146016	71	04399C	0201061240	98	07207Q	0293108680	109	07383B
MS146023	53	15199B	0201061640	98	07207GC	0293110010	101	07264D
	83	07347C	0201061840	98	07207	0293110180	101	07264D
MS146051	31	02199	0201062040	86	07143E	0293110190	101	07264D
MS146053	57	01397C		98	07207	0293110210	101	07264D
MS146059	31	02192F		98	07207GG	0293110520	102	07264E
MS146065	31	02192		98	07207K	0293110530	102	07264E
MS146306	40	03198	0201063640	98	07207G	0293110540	102	07264E
MS146310	83	07347	0201064540	98	07207G	0293110560	102	07264E
MS146351	37	03775	0201065040	98	07207H	0293110570	102	07264E
MS446183	163	14788	0213063010	86	07143G	0293110640	102	07264E
MS471107	83	07108	0230406040	100	07243GC	0293110650	102	07264E
MS650013	76	04996E	0239110550	102	07264E	0293110660	102	07264E
MS660170	15	01988	0240302030	85	07129	0293110670	102	07264E
MS666134	17	01296F	0255201210	100	07247FB	0293110680	102	07264E
MS666135	17	01296H	0258031310	99	07235B	0293110690	102	07264E
MS666136	17	01296EB		99	07235C	0293110700	102	07264E
MS666137	17	01296E	0258031610	99	07235C	0293111090	101	07264
	20	01395M	0258051910	85	07124	0293120180	102	07264GC
MS666220	57	04296	0265061040	99	07227D	0293120210	102	07264GC
S183S05104	163	14798	0265081240	118	07406D	0293205020	103	07277E
S275S04160	161	14265	0265101340	85	07119H	0293212020	103	07277C
S409S00008	151	14198		99	07227GD	0293218020	109	07387
S930P12370	149	14008B	0265121540	99	07227E	0293310190	108	07361C
S930P28070	149	14008C		99	07227K	0293310240	99	07227G
S930P28301	149	14008	0265121840	99	07227P		118	07406B
S930P29970	149	14008C	0265141840	85	07119J	0293316030	111	07307C
S930P34070	160	14205C	0265162040	99	07227E	0293326030	111	07307B
S930P34270	160	14205C	0265242940	85	07119M	0293414130	85	07119F
S930P37170	160	14205B	0265243040	99	07227		111	07307D
S930P37201	160	14205B	0290106310	98	07207GB	0296020010	92	07148
S930P80870	160	14205C	0290106810	85	07104B	0296208050	100	07245D
S930P81170	160	14205C	0290106850	98	07207M	0296210080	100	07245C
S930P90670	160	14205B	0290206210	98	07207BE	0296310030	100	07244E
0066502048	142	12768		98	07207D	0296315020	85	07126D
0105351040	101	07255C	0290206260	98	07207GD	0296318020	100	07244B
0122061640	86	07143F	0291417010	101	07249F	0296322070	85	07126C

部 品 番 号 顺 索 引
PARTS NUMBER INDEX

A7

部品番号 PART NO.	ページ PAGE	見出番号 REF.NO.	部品番号 PART NO.	ページ PAGE	見出番号 REF.NO.	部品番号 PART NO.	ページ PAGE	見出番号 REF.NO.
0296325070	100	07244D	1341534120	86	07136A	1394003400	88	07146D
0296328010	108	07368C	1342000020	92	07154A	1394003500	88	07146D
0296329030	85	07126F	1342150400	92	07149C	1394003600	88	07146D
0296352020	100	07244C	1342160000	86	07144B	1394003700	88	07146D
0296355010	85	07126E	1342170000	86	07144C	1394003800	88	07146D
0297310180	85	07117C	1342170500	86	07144C	1394003900	88	07146D
	99	07225G	1342220000	85	07108C	1394004000	88	07146D
0297314570	85	07117E	1342410021	92	07147C	1394004100	88	07146D
	111	07305C	1342560000	86	07138	1394004200	88	07146D
0297314680	85	07117D	1343030000	86	07146CB	1394004300	88	07146D
	85	07117E	1343030100	86	07146CB	1394004400	88	07146D
0334013024	51	15172C	1343030200	86	07146CB	1394004500	88	07146D
0634831018	52	15184D	1343030300	86	07146CB	1394004600	88	07146D
0945601600	56	01394B	1343030400	86	07146CB	1394004700	88	07146D
1050155330	118	07420	1343060100	85	07102	1394004800	88	07146D
1050190700	118	07420	1343140000	86	07146C	1394004900	88	07146D
1050313910	118	07410A	1343140100	86	07146C	1394005000	88	07146D
1050414130	118	07410A	1343140200	86	07146C	1394005100	88	07146D
1051006210	118	07400A	1343140300	86	07146C	1394005200	88	07146D
1051107550	118	07400A	1343140400	86	07146C	1394005300	88	07146D
1052071200	83	07010A	1343140500	86	07146C	1394005400	89	07146D
	111	07010A	1343140600	86	07146C	1394005500	89	07146D
1052071210	83	07010A	1343161700	85	07113C	1394005600	89	07146D
	111	07010A	1343250300	108	07367	1394005700	89	07146D
1054080410	83	07040A	1343250800	108	07367	1394005800	89	07146D
	98	07040A	1343712800	85	07109	1394005900	89	07146D
1054877690	83	07040A	1344160100	85	07113D	1394006000	89	07146D
	98	07040A	1344960600	86	07137	1394006100	89	07146D
1056361820	83	07030A	1345630900	92	07147D	1394006200	89	07146D
	108	07030A	1392060400	85	07125B	1394006300	89	07146D
1056620710	83	07020A	1392120000	100	07243D	1394006400	89	07146D
	113	07020A	1392180100	100	07243G	1394006500	89	07146D
1056630910	83	07020A	1392180700	100	07243P	1394006600	89	07146D
	113	07020A	1393080900	103	07277B	1394006700	89	07146D
1056812520	83	07030A	1393081000	103	07277B	1394006800	89	07146D
	108	07030A	1394000900	87	07146D	1394080000	108	07383B
1066717821	83	07000A	1394001000	87	07146D	1394080100	109	07383B
1066762332	83	07000A	1394001100	87	07146D	1394080200	109	07383B
1310410500	85	07119	1394001200	87	07146D	1394080300	108	07383B
1310410800	85	07119	1394001300	87	07146D	1394080500	109	07383B
1314244620	92	07155C	1394001400	87	07146D	1394080600	109	07383B
1340009321	85	07123	1394001500	87	07146D	1394081400	101	07264C
1340010000	85	07108B	1394001600	87	07146D	1394081500	101	07264C
1340420100	85	07119K	1394001700	87	07146D	1394100000	101	07264D
1340421400	85	07119K	1394001800	87	07146D	1394100100	101	07264D
1340430800	85	07113E	1394001900	87	07146D	1394101400	102	07264E
1340450100	85	07135B	1394002000	87	07146D	1394101500	102	07264E
1340470000	86	07143C	1394002100	87	07146D	1394101600	102	07264E
1340631720	85	07123	1394002200	87	07146D	1394102700	102	07264E
1341104520	92	07155B	1394002300	87	07146D	1394103000	102	07264D
1341120600	92	07149B	1394002400	87	07146D	1394103100	102	07264D
1341150100	85	07119C	1394002500	87	07146D	1394103200	102	07264D
1341162400	85	07122	1394002600	87	07146D	1394110000	101	07264B
1341171400	92	07151	1394002700	87	07146D	1394110100	101	07264B
1341320300	92	07156E	1394002800	87	07146D	1394110200	101	07264
1341350200	85	07115	1394002900	88	07146D	1394110300	101	07264
1341370100	86	07141	1394003000	88	07146D	1394110400	101	07264
1341438320	85	07106	1394003100	88	07146D	1396100101	100	07245B
1341505820	85	07106	1394003200	88	07146D	1396110000	100	07245B
1341512920	85	07136A	1394003300	88	07146D	1396250000	85	07127

部 品 番 号 顺 索 引
PARTS NUMBER INDEX

A8

部品番号 PART NO.	ページ PAGE	見出番号 REF.NO.	部品番号 PART NO.	ページ PAGE	見出番号 REF.NO.	部品番号 PART NO.	ページ PAGE	見出番号 REF.NO.
1396480300	108	07369	1505833500	120	07432C	1505901100	122	07433B
1397000000	100	07244B	1505833600	120	07432C	1505901200	123	07433B
1397000100	100	07244C	1505833700	120	07432C	1505901300	123	07433B
1397150400	85	07126D	1505833800	120	07432C	1506098100	118	07409
1397220400	85	07126C	1505833900	120	07432C	1506131700	118	07404
1397290400	85	07126F	1505834000	120	07432C	1506241800	123	07486F
1505083300	123	07491	1505834100	120	07432C	1506448900	118	07414
1505251700	123	07491B	1505834200	120	07432C	1506501701	123	07493B
1505390700	123	07433C	1505834300	120	07432C	1506515400	123	07493B
1505390800	123	07433C	1505834400	120	07432C	1520004620	111	07309
1505390900	123	07433C	1505834500	120	07432C	1521001120	111	07315
1505391000	123	07433C	1505834600	120	07432C	1521020400	111	07322C
1505391100	123	07433C	1505834700	121	07432C	1521050200	111	07316B
1505391200	123	07433C	1505834800	121	07432C	1521051500	111	07316B
1505391300	123	07433C	1505834900	121	07432C	1521113221	111	07325
1505391400	123	07433C	1505835000	121	07432C	1521150200	111	07326
1505391620	122	07433B	1505835100	121	07432C	1521150500	111	07326
1505503600	119	07432B	1505835200	121	07432C	1521160200	111	07322B
1505602001	118	07416B	1505835300	121	07432C	1521170400	111	07316C
1505602100	118	07416	1505835400	121	07432C	1521210200	111	07321
1505621400	123	07434B	1505835500	121	07432C	1522002120	111	07010
1505626500	123	07434C	1505835600	121	07432C	1522005620	111	07010
1505626600	123	07434B	1505835700	121	07432C	1523007120	111	07305B
1505652001	123	07488B	1505835800	121	07432C	1523200100	111	07304
1505677100	123	07493C	1505835900	121	07432C	1530212220	100	07238
1505830000	119	07432C	1505836000	121	07432C	1534000800	101	07257GB
1505830100	119	07432C	1505836100	121	07432C	1534000900	101	07257G
1505830200	119	07432C	1505836200	121	07432C	1535564800	99	07225
1505830300	119	07432C	1505836300	121	07432C	1540004700	99	07232A
1505830400	119	07432C	1505836400	121	07432C	1540041022	99	07232A
1505830500	119	07432C	1505836500	121	07432C	1540072900	101	07249C
1505830600	119	07432C	1505836600	121	07432C	1540100100	101	07255D
1505830700	119	07432C	1505836700	121	07432C	1540101100	101	07255C
1505830800	119	07432C	1505836800	121	07432C	1540106000	98	07207B
1505830900	119	07432C	1505836900	121	07432C	1540107300	98	07207E
1505831000	119	07432C	1505837000	121	07432C	1540107900	98	07207B
1505831100	119	07432C	1505837100	121	07432C	1540110100	100	07243F
1505831200	119	07432C	1505837200	122	07432C	1540111700	100	07243K
1505831300	119	07432C	1505837300	122	07432C	1540112200	100	07243BB
1505831400	119	07432C	1505837400	122	07432C	1540112300	100	07243FB
1505831500	119	07432C	1505837500	122	07432C	1540130600	98	07207F
1505831600	119	07432C	1505837600	122	07432C	1540312400	101	07255B
1505831700	119	07432C	1505837700	122	07432C	1540313401	101	07255B
1505831800	119	07432C	1505837800	122	07432C	1540351600	100	07243E
1505831900	119	07432C	1505837900	122	07432C	1540360300	100	07249B
1505832000	119	07432C	1505838000	122	07432C	1540361800	100	07249B
1505832100	119	07432C	1505838100	122	07432C	1540361900	101	07249BB
1505832200	120	07432C	1505838200	122	07432C	1540507720	99	07221B
1505832300	120	07432C	1505838300	122	07432C	1540620400	83	07012
1505832400	120	07432C	1505838400	122	07432C	1540631400	98	07217
1505832500	120	07432C	1505838500	122	07432C	1540636121	98	07217
1505832600	120	07432C	1505838600	122	07432C	1541009220	99	07226A
1505832700	120	07432C	1505838700	122	07432C	1541010020	99	07226A
1505832800	120	07432C	1505838800	122	07432C	1541232320	103	07265
1505832900	120	07432C	1505838900	122	07432C	1541500400	103	07269H
1505833000	120	07432C	1505900600	122	07433B	1541509000	103	07269H
1505833100	120	07432C	1505900700	122	07433B	1541540500	103	07269D
1505833200	120	07432C	1505900800	122	07433B	1541540701	103	07269D
1505833300	120	07432C	1505900900	122	07433B	1541561500	103	07275B
1505833400	120	07432C	1505901000	122	07433B	1541581020	99	07221D

部 品 番 号 顺 索 引
PARTS NUMBER INDEX

A9

部品番号 PART NO.	ページ PAGE	見出番号 REF.NO.	部品番号 PART NO.	ページ PAGE	見出番号 REF.NO.	部品番号 PART NO.	ページ PAGE	見出番号 REF.NO.
1541591100	100	07243C	1544009320	99	07222	1567280800	109	07383B
1541591200	100	07243C	1544012700	98	07207N	1567280900	109	07383B
	100	07243M	1544020600	103	07269GD	1567281000	109	07383B
1541770220	99	07221C	1544045100	99	07217G	1567281100	109	07383B
1541885220	99	07221E	1544045300	101	07255G	1567281200	109	07383C
1541892820	99	07221C	1544067800	100	07243GB	1567281300	109	07383C
1542000120	99	07236C	1544081520	99	07236G	1567281400	109	07383C
1542005401	99	07236C	1544086220	99	07232G	1567281500	109	07383C
1542005501	98	07211B	1544112200	103	07269GB	1567282000	109	07383B
1542041900	98	07211B	1544132600	99	07227GB	1567282100	109	07383B
1542043500	98	07211C	1544225420	98	07208	1567282200	109	07383C
1542060200	103	07277D	1545003320	98	07217A	1567282300	109	07383C
1542062300	98	07216B	1545166520	98	07217A	1568003420	108	07364
1542062400	103	07277D	1550031920	99	07236H	1568016200	108	07358
1542062800	98	07216B	1550043301	101	07262C	1568020420	108	07359
1542065400	98	07216D	1550060700	98	07207BC	1568060900	108	07372
1542107420	100	07236M	1554023800	100	07247C	1568070000	108	07381C
1542114320	99	07236A	1554041700	100	07238	1568070900	108	07381C
1542161920	99	07236A	1554125200	99	07233	1568071100	108	07381
1542302920	100	07239	1556153500	98	07207C	1568080500	109	07389
1542314900	100	07247B	1563001122	108	07364	1568090300	109	07384
1542321220	100	07248C	1563057620	108	07359	1568091620	108	07017
1542348520	100	07239	1563080600	108	07017	1568941600	109	07385B
1542363220	99	07236D	1563090000	108	07369	1568966200	109	07385
1542365200	99	07236D	1563100000	108	07381	1568966300	109	07385
1542370100	100	07247	1563120000	108	07352	1568976100	109	07385
1542371200	100	07247	1563130000	108	07378	1568982820	108	07359A
1542371300	98	07216C	1563130100	108	07378	1592384200	103	07267JB
1542380201	100	07247BB	1563130200	108	07378	1917425100	142	12544A
1542420620	99	07221B	1563130300	108	07378	3000424302	40	03275
1543172000	103	07269P	1563140501	108	07354	3000715301	56	01394C
1543210400	98	07211D	1563140600	108	07354	3003291200	143	12784
1543212000	98	07211D	1563150200	108	07368	3003291300	145	13097
1543220100	98	07213		108	07368B	3004211900	15	01987D
1543244100	101	07262B	1563160000	108	07375	3006813700	162	14384G
1543260300	99	07236B	1563170100	108	07376	3013302300	163	14782
1543265120	99	07236B	1563190100	108	07361B	3016101200	83	07051
1543271900	103	07269G	1563190200	108	07361	3090113709	17	01208
1543277300	103	07269E	1563219700	109	07385	3090400801	40	03300
1543400120	99	07236F	1563220000	109	07387	3090400900	40	03262
1543401920	99	07236F	1563230820	108	07358	3090401600	41	03314
1543506000	100	07248B	1566037200	113	07181B	3090402200	40	03276
1543507800	99	07227C	1566054420	113	07184C	3090410702	41	03302B
1543508700	99	07227B	1566054520	113	07184B	3090510500	40	03146
1543543900	103	07267B	1566055320	113	07184C	3090702501	57	01399
1543553900	102	07264GE	1566055520	113	07184B	3090702600	56	01307H
1543554000	103	07264GE	1566056520	113	07184B	3090702701	57	01399B
1543554100	103	07264GE	1566095300	113	07020	3090702800	19	01385N
1543576320	98	07207JB	1566152600	113	07185B	3090702900	43	03151
1543582500	99	07227D	1566152800	113	07185D	3090703500	56	01307J
1543602800	99	07236E	1566307700	113	07020B	3090705800	56	01333
1543643420	99	07236K	1566311900	113	07020B	3090722300	19	01320
1543715600	99	07227B	1566332100	113	07181C	3091201400	30	02185
1543718300	98	07207JF		113	07181D	3092020100	31	03034
1543762220	98	07209E	1566332900	113	07181	3092200102	35	03022
1543765800	98	07207JG	1566333200	113	07181	3093000501	137	11410
1543833200	99	07236J	1566334800	108	07351	3093601200	62	04161C
1543871920	99	07236K	1566338000	113	07181C	3093602300	76	04925B
1543900200	99	07227C	1567230300	108	07353	3093613500	77	15113
1544005800	101	07252G	1567230400	108	07353B	3093615200	62	04042

部 品 番 号 顺 索 引
PARTS NUMBER INDEX

A10

部品番号 PART NO.	ページ PAGE	見出番号 REF.NO.	部品番号 PART NO.	ページ PAGE	見出番号 REF.NO.	部品番号 PART NO.	ページ PAGE	見出番号 REF.NO.
3093615300	62	04033	3124051203	65	04107			
3093900300	70	04375	3124051500	65	04111B			
3094600500	133	10191B	3124053054	65	04140			
3096102200	118	07403	3124053900	65	04144			
3096102300	118	07405	3124054500	66	04191B			
3096105500	127	05476	3124618702	134	10898B			
3096600091	150	14057B	3170705201	56	01306			
3096801400	160	14216	3193343600	127	05472B			
3096802300	160	14223	4913442200	142	12778			
3097501040	50	15024A	4916814020	143	12798			
3097501070	51	15116	4916855200	142	12571			
3097502060	51	15114	4917400565	142	12500A			
3097502070	51	15115	4917410500	142	12545			
3097504400	52	15176F	4917410501	142	12545			
3097506600	53	15197D	4917414000	142	12516			
3097516200	51	15098B	4917419100	142	12572			
3097520600	50	15073	4917421100	142	12503			
3097520900	50	15001	4917421110	142	12503			
3097521200	51	15172B	4917422200	142	12525			
3097521700	50	15074	4917422300	142	12769D			
3097521800	51	15098C	4917422510	142	12546			
3097521900	50	15034	4917422600	143	12796			
3097522100	50	15061	4917422700	143	12796C			
3097522500	51	15105	4917423100	142	12597			
3097522600	51	15117	4917423200	142	12769			
3097522700	51	15096	4917423300	142	12769E			
3097522800	50	15035	4917430100	142	12606			
3097522900	52	15183C	4917430130	142	12606			
3097523100	50	15051	4917442130	142	12766			
3097523200	51	15106	4917442200	142	12778			
3097523300	51	15121	4917444200	142	12623			
3097523400	51	15097	4917444201	142	12623			
3097523500	50	15037	4917451300	142	12521			
3097524200	51	15107	4918123100	142	12597D			
3097524300	51	15098B	4918801661	142	12500A			
3097524500	50	15033	4918810400	142	12545			
3097524600	50	15023	4918819100	142	12572			
3097525100	52	15184C	4918821500	142	12504			
3110702401	20	01388B	4918822210	142	12525			
3111203902	30	02187	4918822500	142	12546			
3111204100	30	02113	4918825300	142	12544A			
3111204200	30	02115	4918830100	142	12606			
3112304100	44	03295C	4918842100	142	12766			
3113902201	66	04191	4918842300	142	12593			
3117502109	44	03291D	4918842400	142	12596			
3120434200	41	03450	4918845120	142	12623			
3120978101	23	03044	4918855120	142	12521			
3120978201	23	03044						
3120978301	23	03044						
3120978401	23	03044						
3121202300	30	02111						
3121233300	32	03080						
3121733100	37	03798						
3123500044	62	04016						
3123500501	62	04034						
3123674200	62	04161B						
3123674300	62	04161D						
3124050301	65	04115						
3124050500	65	04111C						
3124050900	66	04189						

部 品 名 称 顺 索 引

PARTS NAME INDEX

Silverhorn.CO.UK

Silverhorn.CO.UK

部 品 名 称 顺 索 引
P A R T S N A M E I N D E X

B1

部 品 名 称 P A R T S N A M E	ページ PAGE	見出番号 REF.NO.	部 品 名 称 P A R T S N A M E	ページ PAGE	見出番号 REF.NO.
(A)				25	04956D
AIR COMPRESSOR ASSY	50	15000A	BOLT,ENG OIL LINE	76	04997
ALTERNATOR ASSY	160	14200A		76	04997B
ARMATURE KIT,STARTER	149	14001		76	04997C
(B)			BOLT,ENG OIL PAN	25	01597B
BALL,ENG OIL PUMP INR	62	04099	BOLT,ENG OIL PUMP	62	04096
BALL,STARTER INR	151	14198	BOLT,ENG OIL PUMP INR	62	04098
BEARING & SLEEVE KIT,STARTER	149	14003	BOLT,ENG RR PLATE	31	02199
BEARING SET,CONNROD	35	03050	BOLT,EXHAUST MANIFOLD	139	12099
BEARING SET,CRANKSHAFT	21	03040	BOLT,FLYWHEEL	32	03797
BEARING,AIR COMPRESSOR			BOLT,FLYWHEEL HOUSING	30	02192
CONNROD	50	15001		31	02192BB
BEARING,ALTERNATOR ROTOR	160	14205B		31	02192C
	160	14205C		31	02192E
BEARING,FLYWHEEL DRIVE PINION	31	03035		31	02192F
BEARING,INJECTION PUMP BODY	85	07102	BOLT,FUEL FILTER	79	05399
	85	07102C	BOLT,FUEL INJECTION NOZZLE	123	07494
BEARING,STARTER ARMATURE	149	14008	BOLT,FUEL INJECTION TUBE	123	07499
	149	14008B		123	07499B
	149	14008C		123	07499C
BEARING,T/C SHAFT	142	12503	BOLT,FUEL LINE	79	05496M
BEARING,WATER PUMP	129	10001		80	05496P
	129	10001B	BOLT,FUEL RETURN LINE	127	05477
BELT,ALTERNATOR & OTHERS	129	10040	BOLT,INJECTION PUMP	83	07347
BLOCK ASSY,CYLINDER	7	01300A		83	07347C
BLOCK,INJECTION PUMP BODY	85	07106	BOLT,INJECTION PUMP BODY	85	07104B
BODY ASSY,INJECTION PUMP	83	07009A		85	07104D
	85	07009A	BOLT,INJECTION PUMP COUPLING	113	07181
BOLT SET,STARTER	149	14011		113	07181B
	149	14011B		113	07181C
BOLT,AIR COMPRESSOR	53	15199B		113	07181D
	53	15199C	BOLT,INJECTION PUMP GOVERNOR	98	07207
	53	15199D		98	07207B
	53	15199DC		98	07207BC
	53	15199DE		98	07207BE
BOLT,AIR COMPRESSOR INR	53	15198B		98	07207C
	53	15198C		98	07207D
BOLT,ALTERNATOR	163	14799B		98	07207E
	164	14799C		98	07207F
	164	14799D		98	07207G
	164	14799E		98	07207GB
	164	14799F		98	07207GC
BOLT,ALTERNATOR INR	163	14798		98	07207GD
BOLT,CAMSHAFT	40	03198		98	07207GG
BOLT,CONNROD	35	03006		98	07207H
BOLT,COOLING WATER LINE	133	10198B		98	07207J
	133	10198C		98	07207JB
BOLT,CRANKSHAFT PULLEY	37	03787		98	07207JF
BOLT,CYLINDER BLOCK	21	01397N		98	07207JG
	56	01397		98	07207K
	56	01397B		98	07207M
	57	01397C		98	07207N
	57	01397D		98	07207Q
BOLT,CYLINDER HEAD	17	01298B	BOLT,INJECTION PUMP TIMER	108	07351
	17	01298C	BOLT,INLET MANIFOLD,NO.1	137	11424
BOLT,ENG BREATHER	15	01978		137	11424B
BOLT,ENG OIL COOLER	71	04399	BOLT,INTAKE AIR HEATER	149	11699C
	71	04399C	BOLT,OIL FILTER	66	04199
	71	04399D	BOLT,OIL STRAINER	63	04178
BOLT,ENG OIL FILLER	25	04956B		63	04178C

部 品 名 称 顺 索 引
PARTS NAME INDEX

B2

部 品 名 称 PARTS NAME	ページ PAGE	見出番号 REF.NO.	部 品 名 称 PARTS NAME	ページ PAGE	見出番号 REF.NO.
BOLT,P/S OIL PUMP	167	48959	CAM,INJECTION PUMP TIMER	108	07353
BOLT,ROCKER COVER	15	01198		108	07353B
BOLT,STARTER	151	14199B	CAMSHAFT	40	03100
	151	14199C	CAMSHAFT,INJECTION PUMP BODY	85	07109
	151	14199D	CAP ASSY,ENG OIL FILLER	25	04903A
BOLT,T/C	143	12797	CAP ASSY,STARTER SWITCH	150	14028A
	143	12797B	CAP,CYLINDER BLOCK	20	01395J
BOLT,T/C INR	143	12798		20	01395M
BOLT,TIMING GEAR TRAIN	44	03298D		25	01395Z
	44	03298E	CAP,CYLINDER HEAD	17	01296E
BOLT,TORSIONAL DAMPER	37	03775		17	01296EB
BOLT,VALVE GEAR TRAIN	40	03277B		17	01296F
	40	03277C		17	01296H
BOLT,WATER PUMP	130	10088	CAP,INJECTION PUMP	83	07012
	130	10088D	CAP,INJECTION PUMP GOVERNOR	98	07213
BOOST COMPENSATOR,INJECTION PUMP GOVERNO	98	07208	CAP,INJECTION PUMP TIMER	108	07354
BRACE,ALTERNATOR ADJUSTING	160	14216	CAP,VALVE GEAR TRAIN	40	03275
BRACKET ASSY,ALTERNATOR,FR	160	14224A	CASE,OIL FILTER	65	04107
BRACKET ASSY,ALTERNATOR,RR	160	14225A	CASE,THERMOSTAT	133	10100
BRACKET,AIR COMPRESSOR HEAD PIPE	50	15014	CASE,WATER PUMP	129	10012
BRACKET,ALTERNATOR MOUNTING	160	14223	CENTER BOLT,OIL FILTER	65	04111B
BRACKET,FUEL RETURN LINE	127	05476		65	04111C
BRACKET,INJECTION PUMP	83	07011	CHECK VALVE,CYLINDER BLOCK		
BRACKET,INJECTION PUMP GOVERNOR	98	07209E	PISTON LUBRIC	19	01305
BRACKET,ROCKER SHAFT	41	03302B	CLAMP,ALTERNATOR	162	14381
BRACKET,STARTER GEAR	149	14013	CLAMP,CYLINDER BLOCK	56	01394B
BRACKET,STARTER,CTR	149	14015		56	01394C
BRACKET,STARTER,FR	149	14016	CLAMP,ENG BREATHER	15	01988
BRACKET,STARTER,RR	150	14017	CLAMP,ENG OIL FILLER	26	04993
BREATHER,ENG	15	01303	CLAMP,ENG OIL LINE	76	04994
BRUSH KIT,ALTERNATOR	160	14210		76	04994B
BRUSH,ALTERNATOR	160	14220	CLAMP,FUEL INJECTION TUBE	123	07498B
BRUSH,STARTER	150	14020		123	07498C
BUSHING,CONNROD	35	03016		123	07498F
BUSHING,CYLINDER BLOCK	20	01396B	CLAMP,FUEL LINE	79	07498G
	20	01396C	CLAMP,FUEL RETURN LINE	127	05474
	20	01396D	CLAMP,T/C	143	12799B
	20	01396E	CLIP,AIR COMPRESSOR	53	15194B
	20	01396F		53	15194C
	20	01396G	CLIP,COOLING WATER LINE	133	10193
	21	01396H	CLIP,ENG BREATHER	15	01987D
BUSHING,ENG OIL PUMP INR	62	04095	CLIP,ENG OIL LINE	76	04992
BUSHING,INJECTION PUMP BODY	83	07108	CLIP,FUEL LINE	79	05493
	85	07108B	CLUTCH KIT,STARTER PINION & REDUCTION	150	14024
	85	07108C	CLUTCH,STARTER OVERRUNNING	150	14025
BUSHING,INJECTION PUMP GOVERNOR	98	07211B	COCK,CYLINDER BLOCK WATER DRAIN	56	01306
BUSHING,INJECTION PUMP GOVERNOR	98	07211C	COIL,ALTERNATOR ROTOR	161	14241
BUSHING,INJECTION PUMP GOVERNOR	98	07211D	COLLAR,AIR COMPRESSOR	50	15023
BUSHING,INJECTION PUMP TIMER	108	07352	COLLAR,INJECTION PUMP GOVERNOR	98	07216B
BUSHING,TIMING GEAR TRAIN	43	03107B		98	07216C
	43	03107C	COLLAR,TIMING GEAR TRAIN	43	03271
BUSHING,VALVE GEAR TRAIN (C)	40	03276	CONDENSER,ALTERNATOR	161	14243
CABLE & TERMINAL,ALTERNATOR	161	14227	CONNECTING ROD ASSY	35	03010A
			CONNECTING ROD ASSY,AIR COMPRESSOR	50	15024A
			CONNECTOR,FUEL INJECTION NOZZLE	118	07409

部 品 名 称 顺 索 引
P A R T S N A M E I N D E X

B3

部 品 名 称 P A R T S N A M E	ページ PAGE	見出番号 REF.NO.	部 品 名 称 P A R T S N A M E	ページ PAGE	見出番号 REF.NO.
COUPLING ASSY,INJECTION PUMP	83	07020A		53	15197D
	113	07020A		53	15197E
COUPLING,INJECTION PUMP	113	07020		53	15197F
	113	07020B	EYEBOLT,ENG OIL LINE	76	04996B
COUPLING,T/C HOUSING	142	12516		76	04996C
COVER ASSY,ENG OIL PUMP	62	04007A		76	04996D
COVER ASSY,INJECTION PUMP				76	04996E
GOVERNOR	98	07217A	EYEBOLT,FUEL FILTER	79	05398
COVER,ALTERNATOR RR BRACKET	161	14246B	EYEBOLT,FUEL INJECTION NOZZLE	118	07404
	161	14246C	EYEBOLT,INJECTION PUMP	83	07346
	161	14246D	EYEBOLT,INJECTION PUMP BODY	85	07117C
COVER,CYLINDER BLOCK	56	01307B		85	07117D
	56	01307C		85	07117E
	56	01307D	EYEBOLT,INJECTION PUMP FUEL		
	56	01307H	FEED PUMP	111	07305B
	56	01307J	EYEBOLT,INJECTION PUMP FUEL		
	56	01307K	FEED PUMP	111	07305C
COVER,ENG OIL COOLER	70	04311	EYEBOLT,INJECTION PUMP		
COVER,FLYWHEEL HOUSING TIMING			GOVERNOR	99	07225
POINTER	30	02111	EYEBOLT,INJECTION PUMP		
COVER,FLYWHEEL HOUSING,RR	30	02113	GOVERNOR	99	07225G
COVER,INJECTION PUMP BODY	85	07113C	(F)		
	85	07113D	FILLER,ENG OIL	25	04905
	85	07113E	FLANGE,INJECTION PUMP TIMER	108	07358
COVER,INJECTION PUMP FUEL FEED			FLANGE,WATER PUMP PULLEY DRIVE	129	10016
PUMP	111	07304	FLYWEIGHT ASSY,INJECTION PUMP		
COVER,INJECTION PUMP GOVERNOR	98	07217	GOVERNOR	99	07226A
	99	07217G	FLYWEIGHT ASSY,INJECTION PUMP		
COVER,INJECTION PUMP TIMER	108	07017	TIMER	108	07359A
COVER,P/S OIL PUMP	167	48024	FLYWEIGHT,INJECTION PUMP TIMER	108	07359
COVER,ROCKER	15	01100	FLYWHEEL ASSY	31	03030A
COVER,STARTER MAGNETIC SWITCH	150	14032	FUEL FILTER	79	05300
COVER,T/C COMPRESSOR	142	12521	FUEL FILTER ASSY	79	05300A
COVER,THERMOSTAT CASE	133	10106	FUSE,INTAKE AIR HEATER INR	171	11696
COVER,WATER PUMP	129	10013	(G)		
CRANKCASE ASSY,AIR COMPRESSOR	50	15026A	GASKET KIT,ENG OVERHAUL	13	01070
CRANKSHAFT ASSY	11	03000A	GASKET SET,STARTER YOKE	150	14068
CRANKSHAFT,AIR COMPRESSOR	50	15031	GASKET,AIR COMPRESSOR	52	15189B
(D)				52	15189C
DAMPER,CRANKSHAFT TORSIONAL	35	03022		52	15189D
DAMPER,INJECTION PUMP GOVERNOR	99	07221B		52	15189E
	99	07221C		52	15189F
	99	07221D	GASKET,AIR COMPRESSOR CYLINDER		
	99	07221E	HEAD	50	15033
DEFLECTOR,INJECTION PUMP BODY	85	07115	GASKET,AIR COMPRESSOR CYLINDER		
DEFLECTOR,T/C OIL	142	12525	LINER	50	15034
DIAPHRAGM,INJECTION PUMP			GASKET,AIR COMPRESSOR DELIVERY		
GOVERNOR	99	07222	VALVE	50	15035
DIRECTOR,CYLINDER HEAD WATER	17	01207B	GASKET,AIR COMPRESSOR SUCTION		
DUST SEAL,FUEL INJECTION NOZZLE			VALVE	50	15037
HOLDER	118	07403	GASKET,ALTERNATOR FR BRACKET	161	14284
(E)			GASKET,COOLING WATER LINE	133	10191
ELEMENT KIT,BY-PASS OIL FILTER	65	04130		133	10191B
ELEMENT KIT,MAIN & BY-PASS OIL			GASKET,CRANKSHAFT FR OIL SEAL		
FILTER	65	04180	CASE	57	02023
ELEMENT KIT,OIL FILTER	65	04140	GASKET,CYLINDER BLOCK	21	01399K
ELEMENT,ENG OIL COOLER	70	04322		21	01399M
ENGINE ASSY,SHORT	3	01010A		21	01399N
ENGINE HANGER	57	02200B		57	01399
EYEBOLT,AIR COMPRESSOR	53	15197B		57	01399B

部 品 名 称 顺 索 引
P A R T S N A M E I N D E X

B4

部 品 名 称 P A R T S N A M E	ページ PAGE	見出番号 REF.NO.	部 品 名 称 P A R T S N A M E	ページ PAGE	見出番号 REF.NO.
	57	01399C		62	04161D
	57	01399E	GASKET,STARTER INR	150	14034
GASKET,CYLINDER BLOCK SIDE COVER	56	01326		150	14034B
GASKET,CYLINDER HEAD	17	01210		150	14034C
GASKET,ENG OIL COOLER COVER	70	04334	GASKET,T/C	143	12784
GASKET,ENG OIL FILLER	25	04991B		143	12784B
GASKET,ENG OIL LINE	77	04998B	GASKET,T/C OIL RETURN PIPE TO CYLINDER B	77	12548
	77	04998C	GASKET,T/C OIL RETURN TUBE	77	12537
	77	04998D	GASKET,THERMOSTAT COVER	133	10122
GASKET,ENG OIL PAN	25	01510	GASKET,WATER PUMP	129	10021
GASKET,ENG OIL PAN DRAIN PLUG	25	01521	GAUGE,ENG OIL LEVEL	25	04911
GASKET,ENG RR PLATE	30	02114	GEAR & CASE KIT,ENG OIL PUMP	62	04005
GASKET,EXHAUST MANIFOLD	139	12010	GEAR ASSY,CAM IDLER	43	03132A
GASKET,EXHAUST PIPE	145	13010	GEAR ASSY,INJECTION PUMP IDLER	43	03135A
GASKET,FLYWHEEL HOUSING	30	02116	GEAR ASSY,STARTER REDUCTION	150	14037A
GASKET,FLYWHEEL HOUSING RR COVER	30	02115	GEAR,CAMSHAFT	43	03136
GASKET,FUEL FILTER	79	05394E	GEAR,CRANKSHAFT	43	03026
	79	05394F	GEAR,ENG OIL PUMP DRIVEN	62	04016
	79	07405	GEAR,ENG OIL PUMP IDLER	62	04017
GASKET,FUEL INJECTION NOZZLE	118	07406B	GEAR,INJECTION PUMP DRIVE	43	03118
GASKET,FUEL INJECTION NOZZLE INR	118	07406C	GEAR,STARTER REDUCTION	150	14037
GASKET,FUEL INJECTION NOZZLE INR	118	07406C	GEAR,STARTER REDUCTION INTERNAL	150	14038
GASKET,FUEL INJECTION NOZZLE INR	118	07406D	GEAR,STARTER REDUCTION PINION	150	14039
GASKET,INJECTION PUMP BODY	85	07119	GOVERNOR ASSY,INJECTION PUMP	83	07040A
	85	07119C		98	07040A
	85	07119F	GROMMET,STARTER INR	151	14178
	85	07119H	GUIDE,ENG OIL LEVEL GAUGE	25	04912
	85	07119J	GUIDE,EXHAUST VALVE	17	03470
	85	07119K	GUIDE,INLET VALVE	17	03460
	85	07119M	(H)		
GASKET,INJECTION PUMP FUEL FEED PUMP	83	07307	HARNESS,ALTERNATOR INR	161	14254
GASKET,INJECTION PUMP FUEL FEED PUMP	111	07307B	HEAD ASSY,AIR COMPRESSOR CYLINDER	50	15043A
GASKET,INJECTION PUMP FUEL FEED PUMP	111	07307C	HEAD ASSY,ENG CYLINDER	5	01200A
GASKET,INJECTION PUMP FUEL FEED PUMP	111	07307D	HEAD,FUEL FILTER	79	05314
GASKET,INJECTION PUMP GOVERNOR	99	07227	HEAT SINK KIT,ALTERNATOR MINUS	161	14255B
	99	07227B		161	14255C
	99	07227C	HEATER,INTAKE AIR	149	11610
	99	07227D	HOLDER ASSY,AIR COMPRESSOR BEARING	50	15045A
	99	07227E	HOLDER ASSY,FUEL INJECTION NOZZLE	118	07410A
	99	07227G	HOLDER ASSY,STARTER BRUSH	150	14044A
	99	07227GB	HOLDER,AIR COMPRESSOR DELIVERY VALVE	50	15047
	99	07227GD	HOLDER,AIR COMPRESSOR SUCTION VALVE	50	15051
	99	07227K	HOLDER,INJECTION PUMP BODY	85	07122
	99	07227P	HOSE,CYLINDER BLOCK WATER DRAIN	56	01333
GASKET,INJECTION PUMP TIMER	108	07361	HOSE,ENG BREATHER	15	01951
	108	07361B	HOSE,INJECTION PUMP FUEL FEED	80	07501M
	108	07361C		80	07501N
GASKET,INLET MANIFOLD	137	11410	HOSE,T/C	142	12781
GASKET,INLET MANIFOLD COVER	137	11414	HOSE,T/C OIL RETURN TUBE	77	12543
GASKET,INTAKE AIR HEATER	149	11615	HOSE,THERMOSTAT WATER BY-PASS	133	10134
GASKET,OIL FILTER	66	04192	HOUSING ASSY,INJECTION PUMP GOVERNOR	99	07232A
GASKET,OIL FILTER CASE	65	04115		142	12544A
GASKET,OIL FILTER INR	66	04184B	HOUSING ASSY,T/C BEARING		
GASKET,OIL STRAINER	62	04161B			
	62	04161C			

部 品 名 称 順 索 引
P A R T S N A M E I N D E X

B5

部 品 名 称 P A R T S N A M E	ページ PAGE	見出番号 REF.NO.	部 品 名 称 P A R T S N A M E	ページ PAGE	見出番号 REF.NO.
HOUSING,FLYWHEEL	30	02100	MANIFOLD,EXHAUST,CTR	139	12046
HOUSING,INJECTION PUMP BODY	85	07123	MANIFOLD,INLET,FR	137	11431
HOUSING,INJECTION PUMP FUEL FEED PUMP	111	07309	MANIFOLD,INLET,RR (N)	137	11432
HOUSING,INJECTION PUMP GOVERNOR	99	07232G	NAME PLATE,ENG	169	01911C
HOUSING,INJECTION PUMP TIMER	108	07364	NAME PLATE,T/C	169	01911F
HOUSING,T/C TURBINE	142	12545	NOZZLE & HOLDER ASSY,FUEL INJECTION	142	12571
(I)			NOZZLE,FUEL INJECTION	118	07400A
IMPELLER,INJECTION PUMP GOVERNOR	99	07233	NUT KIT,ALTERNATOR PULLEY	118	07420
IMPELLER,WATER PUMP	129	10025	NUT,AIR COMPRESSOR INR	161	14266
INSERT,T/C BEARING HOUSING	142	12546	NUT,AIR COMPRESSOR INR	52	15184C
INSULATOR,EXHAUST MANIFOLD HEAT	139	12043	NUT,ALTERNATOR	52	15184D
(J)			NUT,ALTERNATOR	163	14788
JOINT,AIR COMPRESSOR	52	15192B	NUT,ALTERNATOR INR	163	14788B
	52	15192D	NUT,CONNROD	163	14787B
	52	15192E	NUT,COOLING WATER LINE	35	14787D
JOINT,AIR COMPRESSOR INR	52	15191	NUT,ENG OIL COOLER INR	133	03031
JOINT,CYLINDER BLOCK	56	01392	NUT,ENG OIL LINE	70	10187
JOINT,ENG OIL LINE	76	04987	NUT,ENG OIL LINE	76	04377
JOINT,ENG OIL PRESSURE GAUGE	58	04298	NUT,ENG OIL PUMP INR	62	04979
JOINT,EXHAUST PIPE	145	13097	NUT,EXHAUST MANIFOLD	139	04079
JOINT,FUEL INJECTION NOZZLE HOLDER	118	07414	NUT,EXHAUST MANIFOLD	139	12096
JOINT,FUEL LINE	79	05491B	NUT,FLYWHEEL HOUSING	30	02188
JOINT,FUEL RETURN LINE	127	05472	NUT,FUEL INJECTION NOZZLE	123	07493B
	127	05472B	NUT,FUEL INJECTION NOZZLE	123	07493C
(K)			NUT,FUEL RETURN LINE	127	05471
KEY,AIR COMPRESSOR	52	15186	NUT,INJECTION PUMP BODY	85	07125B
KEY,ALTERNATOR ROTOR SHAFT PULLEY	161	14265	NUT,INJECTION PUMP BODY	85	07125C
KEY,CAMSHAFT	40	03196	NUT,INJECTION PUMP GOVERNOR	100	07243B
KEY,INJECTION PUMP BODY	85	07124		100	07243BB
KEY,INJECTION PUMP GOVERNOR	99	07235B		100	07243BC
	99	07235C		100	07243C
KEY,TIMING GEAR TRAIN	44	03297		100	07243D
(L)				100	07243E
LEVER ASSY,INJECTION PUMP GOVERNOR	99	07236A		100	07243F
LEVER KIT,STARTER PINION SHIFT	150	14046		100	07243FB
LEVER,INJECTION PUMP GOVERNOR	99	07236B		100	07243G
	99	07236C		100	07243GB
	99	07236D		100	07243GC
	99	07236E		100	07243GD
	99	07236F	NUT,INJECTION PUMP TIMER	108	07367
	99	07236G	NUT,INTAKE SILENCER	149	11682
	99	07236H	NUT,STARTER	151	14195
	99	07236J		151	14195B
	99	07236K	NUT,T/C	142	12779B
	100	07236M	NUT,T/C INR	142	12778
LIMITER,INJECTION PUMP GOVERNOR	100	07238	NUT,TIMING GEAR TRAIN	44	03296B
LINER & PISTON KIT	9	01340		44	03296D
LINER,AIR COMPRESSOR CYLINDER	50	15061		44	03296E
LINER,CYLINDER	19	01342	NUT,VALVE GEAR TRAIN	40	03299
LINK,INJECTION PUMP GOVERNOR	100	07239	NUT,WATER PUMP	129	10084
LOCK,VALVE SPRING RETAINER	41	03450	(O)		
(M)			O-RING,AIR COMPRESSOR	52	15183
MANIFOLD,EXHAUST	139	12000		52	15183C

部 品 名 称 顺 索 引
P A R T S N A M E I N D E X

B6

部 品 名 称 P A R T S N A M E	ページ PAGE	見出番号 REF.NO.	部 品 名 称 P A R T S N A M E	ページ PAGE	見出番号 REF.NO.
	52	15183F	OIL SLINGER,CRANKSHAFT,RR	31	03034
O-RING,COOLING WATER LINE	134	10199	(P)		
O-RING,CYLINDER BLOCK	20	01388	PIN,AIR COMPRESSOR PISTON	50	15074
	20	01388B	PIN,CRANKSHAFT	37	03788
O-RING,CYLINDER HEAD	17	01291		37	03788B
O-RING,ENG BREATHER	15	01983	PIN,CYLINDER BLOCK	19	01387H
O-RING,ENG OIL COOLER	70	04375		20	01387HC
O-RING,ENG OIL COOLER INR	70	04379		20	01387J
	71	04379C		20	01387K
	71	04379E		20	01387M
	71	04379F		20	01387N
O-RING,ENG OIL FILLER	26	04999	PIN,ENG OIL PUMP INR	62	04078
	26	04999B	PIN,FLYWHEEL	32	03796
O-RING,ENG OIL LINE	76	04978	PIN,FUEL INJECTION NOZZLE	123	07491
O-RING,FLYWHEEL HOUSING	30	02187		123	07491B
O-RING,INJECTION PUMP BODY	85	07126C	PIN,INJECTION PUMP BODY	85	07129
	85	07126D	PIN,INJECTION PUMP GOVERNOR	100	07247
	85	07126E		100	07247B
	85	07126F		100	07247BB
O-RING,INJECTION PUMP GOVERNOR	100	07244B		100	07247C
	100	07244C		100	07247FB
	100	07244D	PIN,INJECTION PUMP TIMER	108	07372
	100	07244E	PIN,PISTON	35	03036
O-RING,INJECTION PUMP TIMER	108	07368	PIN,TIMING GEAR TRAIN	44	03294
	108	07368B	PINION KIT,STARTER	150	14054
	108	07368C	PIPE,AIR COMPRESSOR SUCTION	51	15078
O-RING,OIL FILTER	66	04191	PIPE,AIR COMPRESSOR WATER INLET	51	15081
	66	04191B	PIPE,AIR COMPRESSOR WATER		
O-RING,OIL FILTER INR	65	04182	OUTLET	51	15076
O-RING,P/S OIL PUMP	167	48945	PIPE,COOLING WATER OUTLET	133	10151
O-RING,ROCKER COVER	15	01127	PIPE,FUEL RETURN	127	05429
O-RING,T/C INR	143	12796	PIPE,INJECTION PUMP BOOST		
	143	12796C	COMPENSATOR	83	07034
O-RING,TIMING GEAR TRAIN	44	03295B	PIPE,T/C TO INLET MANIFOLD	142	12563
	44	03295C	PISTON	35	03037
O-RING,VALVE GEAR TRAIN	40	03279	PISTON,AIR COMPRESSOR CYLINDER	51	15082
O-RING,WATER PUMP	129	10071	PISTON,INJECTION PUMP FUEL FEED		
	129	10071B	PUMP	111	07315
	129	10071C	PLATE,ALTERNATOR RR BRACKET	161	14286
O-RING,WATER PUMP INR	129	10077	PLATE,CAM IDLER GEAR THRUST	43	03145
OIL COOLER ASSY,ENG	70	04300A	PLATE,CAMSHAFT THRUST	40	03146
OIL FILTER & HEAD ASSY	65	04100A	PLATE,CRANKSHAFT THRUST	23	03044
OIL JET,CYLINDER BLOCK	19	01381	PLATE,CYLINDER BLOCK,RR	30	02122
OIL PAN,ENG	25	01500	PLATE,INJECTION PUMP COUPLING	113	07184B
OIL PUMP ASSY,ENG	62	04000A		113	07184C
OIL SEAL,AIR COMPRESSOR			PLATE,INJECTION PUMP DRIVE GEAR	43	03129
CRANKSHAFT,FR	50	15073	PLATE,INJECTION PUMP GOVERNOR	100	07248B
OIL SEAL,CRANKSHAFT,RR	32	03080		100	07248C
OIL SEAL,CYLINDER BLOCK FR COVER	56	01361	PLATE,INTAKE AIR HEATER CABLE		
OIL SEAL,INJECTION PUMP BODY	85	07127	EARTH	149	11631
OIL SEAL,INJECTION PUMP			PLATE,ROCKER SHAFT THRUST	41	03314
GOVERNOR	100	07245B	PLATE,STARTER SWITCH TO		
OIL SEAL,INJECTION PUMP			TERMINAL	150	14056
GOVERNOR	100	07245C	PLATE,T/C TURBINE BACK	142	12572
OIL SEAL,INJECTION PUMP			PLATE,VALVE CLEARANCE CAUTION	169	01913B
GOVERNOR	100	07245D	PLUG,AIR COMPRESSOR INR	52	15179
OIL SEAL,INJECTION PUMP TIMER	108	07369	PLUG,COOLING WATER LINE	133	10185
OIL SEAL,WATER PUMP SHAFT	129	10049	PLUG,CYLINDER BLOCK	19	01385H
	129	10049B		19	01385J
OIL SLINGER,CRANKSHAFT,FR	57	03033		19	01385K

部 品 名 称 顺 索 引
P A R T S N A M E I N D E X

B7

部 品 名 称 P A R T S N A M E	ページ PAGE	見出番号 REF.NO.	部 品 名 称 P A R T S N A M E	ページ PAGE	見出番号 REF.NO.
	19	01385M	RETAINER,INJECTION PUMP TIMER	108	07376
	19	01385N	RETAINER,OIL FILTER ELEMENT	65	04127B
	56	01385		65	04127C
PLUG,CYLINDER HEAD	17	01287B	RETAINER,VALVE SPRING	41	03405
PLUG,ENG OIL COOLER	70	04338	RING GEAR,FLYWHEEL	32	03057
PLUG,ENG OIL COOLER INR	71	04385	RING SET,AIR COMPRESSOR PISTON	51	15087
PLUG,ENG OIL PAN	25	01598D	RING SET,PISTON	36	03060
PLUG,ENG OIL PRESSURE GAUGE	57	04296	RING,CRANKSHAFT RR OIL SLINGER	32	03083
PLUG,FLYWHEEL HOUSING	30	02185	RING,INJECTION PUMP BODY	86	07141
	30	02185D	RING,T/C SHAFT BEARING THRUST	142	12593
PLUG,FUEL FILTER	79	05392	RING,T/C SHAFT THRUST	142	12596
PLUG,INJECTION PUMP BODY	85	07135B	RING,T/C SHAFT TURBINE PISTON	142	12597
PLUG,INJECTION PUMP FUEL FEED PUMP	111	07316B		142	12597D
PLUG,INJECTION PUMP FUEL FEED PUMP	111	07316C	RIVET,T/C INR	142	12768
PLUG,INJECTION PUMP GOVERNOR	100	07249B	ROCKER ARM,INLET & EXHAUST VALVE	41	03323
	101	07249BB	ROLLER,INJECTION PUMP TIMER	108	07378
	101	07249C	ROTOR KIT,ALTERNATOR	162	14304
	101	07249F	ROTOR,ALTERNATOR (S)	162	14305
PLUG,INJECTION PUMP TIMER	108	07375	SCREW,ALTERNATOR INR	163	14784B
PLUG,INLET MANIFOLD	137	11475		163	14784C
PLUG,OIL FILTER	66	04189		163	14784D
PLUG,T/C	142	12731		163	14784E
PLUG,TIMING GEAR TRAIN	43	03151		163	14784F
PLUG,WATER PUMP	130	10086		163	14784G
PLUG,WATER TEMPERATURE GAUGE	134	10898B		163	14784H
PLUNGER ASSY,INJECTION PUMP BODY	85	07136A	SCREW,FUEL INJECTION NOZZLE	123	07488B
POINTER,FLYWHEEL HOUSING ENG TIMING	30	02124	SCREW,INJECTION PUMP BODY	86	07143C
POINTER,INJECTION PUMP BODY	86	07137		86	07143E
PULLEY & FAN KIT,ALTERNATOR	161	14292	SCREW,INJECTION PUMP GOVERNOR	101	07255B
PULLEY,CRANKSHAFT	35	03047		101	07255C
PULLEY,WATER PUMP	129	10041		101	07255D
PUMP ASSY,FUEL INJECTION	83	07000A		101	07255G
PUMP ASSY,INJECTION PUMP FUEL FEED	83	07010A	SCREW,STARTER INR	151	14185
PUMP ASSY,INJECTION PUMP FUEL FEED	111	07010A	SCREW,VALVE GEAR TRAIN	151	14185B
PUMP,INJECTION PUMP FUEL FEED	111	07010	SEAL RING,EXHAUST MANIFOLD	40	03266B
PUSH ROD,FUEL INJECTION NOZZLE HOLDER	119	07432B	SEAL RING,EXHAUST PIPE	139	12092
PUSH ROD,FUEL INJECTION NOZZLE HOLDER	119	07432C	SEAL RING,STARTER	139	12092B
PUSH ROD,INJECTION PUMP GOVERNOR	101	07252G	SEAL UNIT,WATER PUMP SHAFT	145	13085
PUSH ROD,ROCKER ARM (R)	41	03316	SEAL,CYLINDER LINER	150	14069
RACK,INJECTION PUMP BODY	86	07138	SEAL,ROCKER COVER BOLT	129	10043
RECTIFIER,ALTERNATOR	161	14296B	SEAL,CYLINDER LINER	19	01320
	162	14296C	SEAL,ROCKER COVER BOLT	15	01134
REGULATOR,ALTERNATOR	162	14297	SEAL,VALVE STEM	41	03440
RELAY,INTAKE AIR HEATER CONTROL	171	14921	SEAT,AIR COMPRESSOR DELIVERY VALVE	51	15096
RELAY,STARTER SAFETY CONTROL	150	14057B	SEAT,AIR COMPRESSOR SUCTION VALVE	51	15097
RETAINER,ALTERNATOR FR BEARING	162	14301	SEAT,ENG OIL PUMP RELIEF VALVE	62	04033
RETAINER,ALTERNATOR FR BEARING, RR	162	14303	SEAT,EXHAUST VALVE	17	03407
RETAINER,FLYWHEEL HOUSING OIL SEAL	30	02174	SEAT,FUEL INJECTION NOZZLE HOLDER	118	07416
			SEAT,FUEL INJECTION NOZZLE HOLDER	118	07416B
			SEAT,INJECTION PUMP BODY	86	07144B
			SEAT,INJECTION PUMP GOVERNOR	86	07144C
				101	07257G

部 品 名 称 顺 索 引
P A R T S N A M E I N D E X

B8

部 品 名 称 P A R T S N A M E	ページ PAGE	見出番号 REF.NO.	部 品 名 称 P A R T S N A M E	ページ PAGE	見出番号 REF.NO.
SEAT,INJECTION PUMP TIMER	101	07257GB	SNAP RING,T/C INR	142	12769
	108	07381		142	12769D
	108	07381C		142	12769E
SEAT,INLET VALVE	17	03411	SNAP RING,WATER PUMP INR	130	10098
SEAT,VALVE SPRING	41	03412		130	10098B
SET SCREW,VALVE GEAR TRAIN	40	03262	SPACER,ALTERNATOR	163	14782
SHAFT & TURBINE,T/C	142	12606		163	14782E
SHAFT,CAM IDLER GEAR	43	03155B	SPACER,FUEL INJECTION NOZZLE	123	07486F
	43	03155C	SPACER,INJECTION PUMP TIMER	109	07389
SHAFT,ENG OIL PUMP DRIVEN GEAR	62	04034	SPACER,WATER PUMP INR	130	10096B
SHAFT,ENG OIL PUMP IDLER GEAR	62	04035	SPRING PIN,CYLINDER BLOCK	19	01386M
SHAFT,INJECTION PUMP GOVERNOR	101	07262B	SPRING PIN,CYLINDER HEAD	17	01288
	101	07262C	SPRING PIN,TIMING GEAR TRAIN	44	03293B
SHAFT,ROCKER ARM	40	03300	SPRING,AIR COMPRESSOR DELIVERY VALVE	51	15105
SHAFT,WATER PUMP	129	10044	SPRING,AIR COMPRESSOR SUCTION VALVE	51	15106
SHIM,FUEL INJECTION NOZZLE	122	07433B	SPRING,AIR COMPRESSOR UNLOADER VALVE	51	15107
	123	07433C	SPRING,ALTERNATOR BRUSH	162	14334
SHIM,INJECTION PUMP BODY	86	07146C	SPRING,ENG OIL COOLER BY-PASS VALVE	70	04346
	86	07146CB	SPRING,ENG OIL PUMP RELIEF VALVE	62	04042
	87	07146D	SPRING,FUEL INJECTION NOZZLE HOLDER	123	07434B
SHIM,INJECTION PUMP BRACKET	83	07051	SPRING,FUEL INJECTION NOZZLE HOLDER	123	07434C
SHIM,INJECTION PUMP GOVERNOR	101	07264	SPRING,INJECTION PUMP BODY	92	07149B
	101	07264B		92	07149C
	101	07264C	SPRING,INJECTION PUMP FUEL FEED PUMP	111	07322B
	101	07264D	SPRING,INJECTION PUMP FUEL FEED PUMP	111	07322C
	102	07264E	SPRING,INJECTION PUMP GOVERNOR	103	07269D
	102	07264GC		103	07269E
	102	07264GE		103	07269G
	103	07264JB		103	07269GB
	103	07264JC		103	07269GD
SHIM,INJECTION PUMP TIMER	108	07383B	SPRING,INJECTION PUMP TIMER	109	07269H
	109	07383C		109	07269P
SLEEVE,AIR COMPRESSOR CRANKSHAFT	51	15095		109	07385
SLEEVE,INJECTION PUMP BODY	92	07147C	SPRING,STARTER BRUSH	150	07385B
	92	07147D	SPRING,VALVE,INR	41	14076
SLEEVE,INJECTION PUMP GOVERNOR	103	07265	SPRING,VALVE,OTR	41	03417
SLEEVE,T/C INR	142	12766	STARTER ASSY	149	14000A
SNAP RING,AIR COMPRESSOR INR	51	15098B	STATOR,ALTERNATOR	162	14335
	51	15098C	STAY,AIR COMPRESSOR	52	15176F
SNAP RING,FLYWHEEL	32	03795	STAY,ENG OIL FILLER	25	04985
SNAP RING,INJECTION PUMP BODY	92	07148	STAY,ENG OIL LINE	76	04973B
SNAP RING,INJECTION PUMP FUEL FEED PUMP	111	07321		76	04973C
SNAP RING,INJECTION PUMP GOVERNOR	103	07267B	STAY,FUEL INJECTION TUBE	123	07495
SNAP RING,INJECTION PUMP GOVERNOR	103	07267C	STAY,FUEL LINE	79	05482
SNAP RING,INJECTION PUMP GOVERNOR	103	07267F	STAY,FUEL RETURN LINE	127	05467
SNAP RING,INJECTION PUMP GOVERNOR	103	07267G	STOPPER KIT,STARTER PINION	151	14077
SNAP RING,INJECTION PUMP GOVERNOR	103	07267H	STOPPER,INJECTION PUMP BODY	92	07151
SNAP RING,INJECTION PUMP GOVERNOR	103	07267JB	STRAINER,ENG OIL PAN	62	04124
SNAP RING,INJECTION PUMP GOVERNOR	103	07267JC	STUD,AIR COMPRESSOR	52	15174B
SNAP RING,INJECTION PUMP TIMER	109	07384	STUD,COOLING WATER LINE	133	10183
SNAP RING,PISTON	37	03798	STUD,CYLINDER BLOCK	19	01383

部 品 名 称 顺 索 引
P A R T S N A M E I N D E X

B9

部 品 名 称 P A R T S N A M E	ページ PAGE	見出番号 REF.NO.	部 品 名 称 P A R T S N A M E	ページ PAGE	見出番号 REF.NO.
STUD,CYLINDER HEAD	17	01282B		51	15172C
STUD,ENG OIL LINE	76	04972		51	15172D
STUD,EXHAUST MANIFOLD	139	12089	WASHER,ALTERNATOR	162	14384
STUD,STARTER	151	14192		162	14384B
SWITCH KIT,STARTER MAGNETIC	151	14082B		162	14384C
SWITCH,OIL FILTER BY-PASS	65	04101		162	14384D
(T)				162	14384F
TAPPET ASSY,INJECTION PUMP BODY	92	07154A		162	14384G
TAPPET,INJECTION PUMP FUEL FEED			WASHER,ENG OIL COOLER INR	70	04378C
PUMP	111	07325		70	04378E
TAPPET,VALVE	40	03172	WASHER,FLYWHEEL HOUSING	30	02178
TERMINAL KIT,ALTERNATOR	162	14337		30	02178C
	162	14337B	WASHER,FUEL RETURN LINE	127	05466
	162	14337D	WASHER,INJECTION PUMP BODY	92	07156C
THERMOSTAT KIT	133	10110		92	07156D
THRUST BEARING,T/C	142	12504		92	07156E
TIMER ASSY,INJECTION PUMP	83	07030A	WASHER,INJECTION PUMP COUPLING	113	07185B
	108	07030A		113	07185C
TUBE,AIR COMPRESSOR OIL FEED	77	15113		113	07185D
TUBE,CYLINDER HEAD NOZZLE			WASHER,INJECTION PUMP GOVERNOR	103	07277
HOLDER	17	01208		103	07277B
TUBE,ENG OIL LINE	76	04925B		103	07277BB
	76	04925C		103	07277C
	76	04925D		103	07277D
TUBE,ENG OIL PUMP OUTLET	62	04045		103	07277E
TUBE,FUEL INJECTION	118	07429		103	07277F
TUBE,FUEL INJECTION NOZZLE FUEL				103	07277G
RETURN	127	07512		104	07277GB
TUBE,FUEL INJECTION NOZZLE FUEL				104	07277GD
RETURN	127	07512B		104	07277J
TUBE,FUEL LINE	79	05480M	WASHER,INJECTION PUMP TIMER	109	07387
	79	05480N		109	07387B
TUBE,INJECTION PUMP FUEL			WASHER,OIL FILTER	65	04144
OVERFLOW	127	07507	WASHER,ROCKER COVER	15	01182
TUBE,INJECTION PUMP GOVERNOR	103	07275B	WASHER,STARTER	151	14191
TUBE,T/C OIL FEED	77	12617		151	14191B
TUBE,T/C OIL RETURN	77	12621	WASHER,TIMING GEAR TRAIN	43	03291B
	77	12621B		44	03291D
TURBOCHARGER ASSY	142	12500A	WASHER,VALVE GEAR TRAIN	40	03264
(V)			WATER PUMP ASSY	129	10000A
VALVE KIT,AIR COMPRESSOR			WATER PUMP KIT	129	10010
DELIVERY	51	15114	WHEEL,T/C COMPRESSOR	142	12623
VALVE KIT,AIR COMPRESSOR			WIRE,ALTERNATOR LEAD	163	14766
SUCTION	51	15115	(Y)		
VALVE KIT,AIR COMPRESSOR			YOKE,STARTER	151	14086
UNLOADER	51	15116			
VALVE,AIR COMPRESSOR DELIVERY	51	15117			
VALVE,AIR COMPRESSOR SUCTION	51	15121			
VALVE,ENG OIL COOLER BY-PASS	70	04353			
VALVE,ENG OIL PRESSURE					
REGULATING	76	04232			
VALVE,EXHAUST	41	03420			
VALVE,INJECTION PUMP BODY	92	07155B			
	92	07155C			
VALVE,INJECTION PUMP FUEL FEED					
PUMP	111	07326			
VALVE,INLET	41	03410			
(W)					
WASHER SET,STARTER GEAR SHAFT	151	14084			
WASHER,AIR COMPRESSOR INR	51	15172B			

Silverhorn.CO.UK

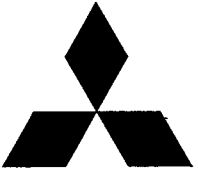

Silverh... UK

